



**INSTALLATION, OPERATION AND
MAINTENANCE INSTRUCTIONS**



**Water-Cooled Screw Chillers
Water-sourced screw heat pumps**

30XW/30XW-P
30XWH/30XWHP

Nominal cooling capacity: 269-1736 kW
Nominal heating capacity: 317-2019 kW
50 Hz

AQUAFORCE.

CONTENTS

1 - INTRODUCTION	5
1.1 - Installation safety considerations	5
1.2 - Equipment and components under pressure	6
1.3 - Maintenance safety considerations	6
1.4 - Repair safety considerations	7
2 - PRELIMINARY CHECKS	9
2.1 - Check equipment received	9
2.2 - Moving and siting the unit.....	9
3 - DIMENSIONS, CLEARANCES	10
3.1 - 30XW-/30XWH- 254-852 – 30XW-P/30XWHP 512-862	10
3.2 - 30XW-/30XWH- 1002-1552 – 30XW-P/30XWHP 1012-1464	11
3.3 - 30XW-/30XWH- 1652-1702 – 30XW-P/30XWHP 1612-1762	12
4 - PHYSICAL AND ELECTRICAL DATA	13
4.1 - Physical data, units without options 150 and 6	13
4.2 - Electrical data, units without options 150 and 6	16
4.3 - Short-circuit stability current for all units.....	19
4.4 - Compressor electrical data 30XW	19
4.5 - Compressor usage per circuit (A, B)	19
5 - ELECTRICAL CONNECTION	21
5.1 - Power supply.....	21
5.2 - Voltage phase imbalance (%).....	21
5.3 - Power connection/disconnect switch.....	21
5.4 - Recommended wire sections	21
5.5 - Power cable entry.....	22
5.6 - Field control wiring	22
5.7 - 24 and 230 V power reserve for the user.....	22
6 - APPLICATION DATA	23
6.1 - Operating limits for 30XW units.....	23
6.2 - Minimum chilled water flow	23
6.3 - Maximum chilled water flow	23
6.4 - Condenser water flow rate	23
6.5 - Standard and optional number of water passes.....	23
6.6 - Evaporator and condenser water flow rates.....	24
6.7 - Variable flow evaporator.....	24
6.8 - System minimum water volume	24
6.9 - Evaporator pressure drop curves	25
6.10 - Condenser pressure drop curves.....	25
7 - WATER CONNECTIONS	26
7.1 - Operating precautions	26
7.2 - Water connections.....	27
7.3 - Flow control	28
7.4 - Evaporator and condenser water box bolt tightening	28
7.5 - Operation of two units in master/slave mode	28
8 - HEAT MACHINE UNITS 30XWH- AND 30XWHP	29
8.1 - Physical data for Heat Machine units	29
8.2 - Electrical data for Heat Machine units.....	29
8.3 - Dimensions and clearances for Heat Machine units	29
8.4 - Operating range for Heat Machine units	29
8.5 - Operating modes for Heat Machine units.....	29
9 - OPTION FOR HIGH CONDENSING TEMPERATURE (OPTION 150)	30
9.1 - Physical data, units with option 150	30
9.2 - Electrical data, units with option 150	33
9.3 - Dimensions and clearances, units with option 150	35
9.4 - Operating limits, units with option 150.....	35
10 - OPTION 8 AND 6 FOR LIGHT AND LOW BRINE TEMPERATURE WITH ETHYLENE AND PROPYLENE GLYCOL	36
10.1 - Physical data, unit with option 6	37
10.2 - Operating range, units with 6 and 8	37
11 - OPTION 33: 90-10 COPPER-NICKEL CONDENSERS	38
11.1 - Description.....	38
11.2 - Condenser water flow rate.....	38
11.3 - Operating limits with option 33	38
11.4 - Installation and Maintenance.....	38

CONTENTS

12 - MAJOR SYSTEM COMPONENTS AND OPERATION DATA	39
12.1 - Direct-drive twin-screw compressor with variable capacity slide valve	39
12.2 - Pressure vessels	39
12.3 - Electronic expansion valve (EXV)	40
12.4 - Moisture indicator	40
12.5 - Filter drier	40
12.6 - Sensors	40
12.7 - SRMCR high-pressure safety circuit	40
13 - OPTIONS	42
14 - STANDARD MAINTENANCE	44
14.1 - Level 1 maintenance	44
14.2 - Level 2 maintenance	44
14.3 - Level 3 (or higher) maintenance.....	44
14.4 - Tightening of the electrical connections	44
14.5 - Tightening torques for the main bolts and screws	45
14.6 - Evaporator and condenser maintenance	45
14.7 - Compressor maintenance	45
14.8 - High pressure safety loop periodic test	46
15 - FINAL SHUTDOWN	47
15.1 - Shutting down.....	47
15.2 - Recommendations for disassembly	47
15.3 - Fluids to be recovered for treatment	47
15.4 - Materials to be recovered for recycling	47
15.5 - Waste electrical and electronic equipment (WEEE).....	47
16 - START-UP CHECKLIST FOR 30XW LIQUID CHILLERS (USE FOR JOB FILE)	48

This manual applies to the following four 30XW unit types:

- 30XW-- Standard-efficiency units
- 30XW-P High-efficiency units

and

- 30XWH- Heat Machine standard-efficiency units
- 30XWHP Heat Machine high-efficiency units

For the operation of the control please refer to the SmartVu™ control manual.

The illustrations in this document are for illustrative purposes only and not part of any offer for sale or contract. The manufacturer reserves the right to change the design at any time without notice.

1 - INTRODUCTION

The 30XW Aquaforce units are designed to cool water for the air conditioning of buildings and industrial processes.

Prior to the initial start-up of the 30XW units, the people involved in the on-site installation, start-up, operation, and maintenance of this unit should be thoroughly familiar with these instructions and the specific project data for the installation site.

The 30XW liquid chillers are designed to provide a very high level of safety during installation, start-up, operation and maintenance. They will provide safe and reliable service when operated within their application range.

They are designed for an operating life of 15 years by assuming a 75% utilisation factor; that is approximately 100,000 operating hours.

This manual provides the necessary information to familiarize yourself with the control system before performing start-up procedures. The procedures in this manual are arranged in the sequence required for machine installation, start-up, operation and maintenance.

Always ensure that all required safety measures are followed, including those in this document, such as: wearing protective clothing (gloves, safety glasses and shoes) using appropriate tools, employing qualified and skilled technicians (electricians, refrigeration engineers) and following local regulations.

To find out, if these products comply with European directives (machine safety, low voltage, electromagnetic compatibility, equipment under pressure etc.) check the declarations of conformity for these products.

1.1 - Installation safety considerations

Access to the unit must be reserved to authorised personnel, qualified and trained in monitoring and maintenance. The access limitation device must be installed by the customer (e.g. cut-off, enclosure).

After the unit has been received, when it is ready to be installed or reinstalled, and before it is started up, it must be inspected for damage. Check that the refrigerant circuit(s) is (are) intact, especially that no components or pipes have shifted (e.g. following a shock). If in doubt, carry out a leak tightness check and verify with the manufacturer that the circuit integrity has not been impaired. If damage is detected upon receipt, immediately file a claim with the shipping company.

Carrier strongly recommends employing a specialised company to unload the machine.

It is compulsory to wear personal protection equipment.

Do not remove the skid or the packaging until the unit is in its final position. These units can be moved with a fork lift truck, as long as the forks are positioned in the right place and direction on the unit.

The units can also be lifted with slings, using only the designated lifting points marked on the unit.

Use slings or lifting beams with the correct capacity, and always follow the lifting instructions on the certified drawings supplied with the unit. Do not tilt the unit more than 15°.

Safety is only guaranteed, if these instructions are carefully followed. If this is not the case, there is a risk of material deterioration and injuries to personnel.

Never cover any protection devices.

This applies to the relief valves (if used) in the refrigerant or heat transfer medium circuits, the fuse plugs and the pressure switches.

Ensure that the valves are correctly installed, before operating the unit.

DO NOT OBSTRUCT ANY PROTECTIVE DEVICES:

This applies to any fusible plugs, rupture disks and valves fitted on the refrigerant or heat transfer fluid circuits. Check whether the original protection plugs are still present at the valve outlets. These plugs are generally made of plastic and should not be used. If they are still present, please remove them. Fit devices at the valve or discharge piping outlets to prevent the penetration of foreign bodies (dust, building debris, etc.) and atmospheric agents (water can form rust or ice). These devices, as well as the discharge piping, must not impair operation or lead to a pressure drop that is higher than 10% of the set pressure.

Classification and control

In accordance with the Pressure Equipment Directive and national usage monitoring regulations in the European Union the protection devices for these machines are classified as follows:

Classification of safety devices

	Safety device ⁽¹⁾	Device for damage limitation in the event of an external fire ⁽²⁾
Refrigerant side		
High pressure safety loop ⁽³⁾	x	
External relief valve ⁽⁴⁾		x
Rupture disk		x
Heat transfer fluid side		
External relief valve	(5)	(5)

(1) Classified for protection in normal service situations.

(2) Classified for protection in abnormal service situations. These devices are sized for fires with a thermal flow of 10kW/m². No combustible matter should be placed within 6.5m of the unit.

(3) High pressure safety loop = SRMCR as described in component section of this manual and in electrical diagram.

(4) The instantaneous over-pressure limitation of 10% of the operating pressure does not apply to this abnormal service situation. The setting of the device to a value above the service pressure is allowed and complies with the applicable standards. In this case either the design temperature or the high pressure safety loop ensures that the maximum allowable pressure is not exceeded in normal service situations.

(5) The selection of these relief valves must be made by the personnel responsible for completing the hydraulic installation.

If the relief valves are installed on a change-over valve, this is equipped with a relief valve on each of the two outlets. Only one of the two relief valves is in operation, the other one is isolated. Never leave the change-over valve in the intermediate position, i.e. with both ways open bring the actuator in abutment, front or back according to the outlet to isolate. If a relief valve is removed for checking or replacement please ensure that there is always an active relief valve on each of the change-over valves installed in the unit.

All factory-installed relief valves are lead-sealed to prevent any calibration change.

The external relief valves must always be vented to outside if the units are installed in a closed space. Refer to the installation regulations, for example those of European standard EN 378 and EN 13136. These pipes must be installed in a way that ensures that people and property are not exposed to vented refrigerant. As the fluids can be diffused in the air, ensure that refrigerant is discharged away from building air intakes, relief valves must be checked periodically. The valves must be checked periodically.

The external relief valves and the fuses are designed and installed to ensure damage limitation in case of a fire.

In accordance with the regulations applied for the design, the European directive on equipment under pressure and in accordance with the national usage regulations:

- These relief valves and fuses are not safety accessories but damage limitation accessories in case of a fire,
- The high pressure switches are the safety accessories.

1 - INTRODUCTION

The relief valve must only be removed if the fire risk is fully controlled and after checking that this is allowed by local regulations and authorities. This is the responsibility of the operator.

When the unit is subjected to fire, safety devices prevent rupture due to over-pressure by releasing refrigerant. The fluid may then be decomposed into toxic residues when subjected to the flame:

- Stay away from the unit
- Set up warnings and recommendations for personnel in charge to stop the fire.
- Fire extinguishers appropriate to the system and the refrigerant type must be easily accessible.

The external relief valves must in principle be connected to discharge pipes for units installed in a room. Refer to the installation regulations, for example those of European standards EN 378 and EN 13136.

They include a sizing method and examples for configuration and calculation. Under certain conditions these standards permit connection of several valves to the same discharge pipe. Note: Like all other standards these EN standards are available from national standards organizations.

These pipes must be installed in a way that ensures that people and property are not exposed to refrigerant leaks. These fluids may be diffused in the air, but far away from any building air intake, or they must be discharged in a quantity that is appropriate for a suitably absorbing environment.

It is recommended to install an indicating device to show if part of the refrigerant has leaked from the valve. The presence of oil at the outlet orifice is a useful indicator that refrigerant has leaked. Keep this orifice clean to ensure that any leaks are obvious.

The calibration of a valve that has leaked is generally lower than its original calibration. The new calibration may affect the operating range. To avoid a nuisance tripping or leaks, replace or re-calibrate the valve.

Periodic check of the relief valves: See paragraph 1.3 "Maintenance safety considerations".

Provide a drain in the discharge circuit, close to each relief valve, to avoid an accumulation of condensate or rain water.

Ensure good ventilation, as accumulation of refrigerant in an enclosed space can displace oxygen and cause asphyxiation or explosions.

Inhalation of high concentrations of vapour is harmful and may cause heart irregularities, unconsciousness, or death. Vapour is heavier than air and reduces the amount of oxygen available for breathing. These products cause eye and skin irritation. Decomposition products are hazardous.

1.2 - Equipment and components under pressure

The units are intended to be stored and operate in an environment where the ambient temperature must not be less than the lowest allowable temperature indicated on the nameplate. See section "11.2 - Pressure vessels".

1.3 - Maintenance safety considerations

Carrier recommends the following drafting for a logbook (the table below should not be considered as reference and does not involve Carrier responsibility):

Intervention		Name of the commissioning engineer	Applicable national regulations	Verification Organism
Date	Nature (1)			

(1) Maintenance, repairs, regular verifications (EN 378), leakage, etc.

Engineers working on the electric or refrigeration components must be authorized, trained and fully qualified to do so.

All refrigerant circuit repairs must be carried out by a trained person, fully qualified to work on these units. He must have been trained and be familiar with the equipment and the installation. All welding operations must be carried out by qualified specialists.

The insulation must be removed and heat generation must be limited by using a wet cloth.

Any manipulation (opening or closing) of a shut-off valve must be carried out by a qualified and authorised engineer. These procedures must be carried out with the unit shut-down.

NOTE: The unit must never be left shut down with the liquid line valve closed, as liquid refrigerant can be trapped between this valve and the expansion device. (This valve is situated on the liquid line before the filter drier box.)

Equip the engineers that work on the unit as follows:

Personal protection equipment (PPE) (1)	Operations		
	Handling	Maintenance, service	Welding or brazing(2)
Protective gloves, eye protection, safety shoe, protective clothing. Fuse plug	x	x	x
Ear protection.		x	x
Filtering respirator.			x

(1) We recommend to follow the instructions in EN 378-3.

(2) Performed in the presence of A1 refrigerant according to EN 378-1.

Never work on a unit that is still energized.

Never work on any of the electrical components, until the general power supply to the unit has been cut using the disconnect switch(es) in the control box(es).

If any maintenance operations are carried out on the unit, lock the power supply circuit in the open position ahead of the machine.

If the work is interrupted, always ensure that all circuits are still deenergized before resuming the work.

ATTENTION: Even if the unit has been switched off, the power circuit remains energized, unless the unit or circuit disconnect switch is open. Refer to the wiring diagram for further details. Attach appropriate safety labels.

Operating checks:

IMPORTANT INFORMATION REGARDING THE REFRIGERANT USED:

- This product contains fluorinated greenhouse gas covered by the Kyoto protocol
Fluid type: R134a
Global Warming Potential (GWP): 1430

CAUTION:

1. Any intervention on the refrigerant circuit of this product should be performed in accordance with the applicable legislation. In the EU, the regulation is called F-Gas, N°517/2014.
2. Ensure that the refrigerant is never released to the atmosphere during installation, maintenance or equipment disposal.
3. The deliberate gas release into the atmosphere is not allowed.
4. If a refrigerant leak is detected, ensure that it is stopped and repaired as quickly as possible.
5. Only a qualified and certified personnel can perform installation operations, maintenance, refrigerant circuit leak test as well as the equipment disposal and the refrigerant recovering.
6. The gas recovery for recycling, regeneration or destruction is at customer charge.

1 - INTRODUCTION

7. **Periodic leak tests have to be carried out by the customer or by third parties. The EU regulation set the periodicity here after:**

System WITHOUT leakage detection		No check	12 months	6 months	3 months
System WITH leakage detection		No check	24 months	12 months	6 months
Refrigerant charge/ circuit (CO ₂ equivalent)		< 5 tons	5 ≤ charge < 50 tons	50 ≤ charge < 500 tons	Charge > 500 tons ⁽¹⁾
Refrigerant charge/ Circuit (kg)	R134A (GWP 1430)	Charge < 3,5 kg	3,5 ≤ charge < 34,9 kg	34,9 ≤ charge < 349,7 kg	Charge > 349,7 kg
	R407C (GWP 1774)	Charge < 2,8 kg	2,8 ≤ charge < 28,2 kg	28,2 ≤ charge < 281,9 kg	Charge > 281,9 kg
	R410A (GWP 2088)	Charge < 2,4 kg	2,4 ≤ charge < 23,9 kg	23,9 ≤ charge < 239,5 kg	Charge > 239,5 kg
	HFO's: R1234ze	No requirement			

(1) From 01/01/2017, units must be equipped with a leakage detection system

8. **A logbook must be established for equipments subject to periodic leak tests. It should contain the quantity and the type of fluid present within the installation (added and recovered), the quantity of recycled fluid, regenerated or destroyed, the date and output of the leak test, the designation of the operator and its belonging company, etc.**

9. **Contact your local dealer or installer if you have any questions.**

- During the life-time of the system, inspection and tests must be carried out in accordance with national regulations.

PROTECTION DEVICE CHECKS:

Periodic inspections of the safety devices and external overpressure devices (external relief valves) must be carried out in accordance with national regulations.

The safety device shall be tested at least once a year to verify good operation and cut out value.

The company or organisation that conducts a pressure switch test shall establish and implement a detailed procedure to fix:

- Safety measures
- Measuring equipment calibration
- Validating operation of protective devices
- Test protocols
- Recommissioning of the equipment.

An example of test procedure without removing the pressure switch is given from Section 13.8 of this manual. Consult Carrier Service for this type of test.

CAUTION: If the test leads to replacing the pressure switch, it is necessary to recover the refrigerant charge, these pressure switches are not installed on automatic valves (Schraeder type).

At least once a year thoroughly inspect the protection devices (valves). If the machine operates in a corrosive environment, inspect the protection devices more frequently.

Ensure regularly that the vibration levels remain acceptable and close to those at the initial unit start-up.

Before opening a refrigerant circuit, purge and consult the pressure gauges.

Change the refrigerant when there are equipment failures, following a procedure such as the one described in NF E29-795 or carry out a refrigerant analysis in a specialist laboratory.

If the refrigerant circuit remains open for longer than a day after an intervention (such as a component replacement), the openings must be plugged and the circuit must be charged with nitrogen (inertia principle). The objective is to prevent penetration of atmospheric humidity and the resulting corrosion on the internal walls and on non-protected steel surfaces.

1.4 - Repair safety considerations

Equip the engineers that work on the unit with the protections described in section 1.3 above.

It is compulsory to wear personal protection equipment.

The insulation must be removed and warming up must be limited by using a wet cloth.

Before opening the unit always ensure that the circuit has been purged.

If work on the evaporator is required, ensure that the piping from the compressor is no longer pressurised (as the valve is not leaktight in the compressor direction.)

All installation parts must be maintained by the personnel in charge, in order to avoid material deterioration and injuries to people. Faults and leaks must be repaired immediately. The authorized technician must have the responsibility to repair the fault immediately. Each time repairs have been carried out to the unit, the operation of the protection devices must be re-checked.

Comply with the regulations and recommendations in unit and HVAC installation safety standards, such as: EN 378, ISO 5149, etc.

If a leak occurs or if the refrigerant becomes contaminated (e.g. by a short circuit in a motor) remove the complete charge using a recovery unit and store the refrigerant in mobile containers.

Repair the leak detected and recharge the circuit with the total R-134a charge, as indicated on the unit name plate. Certain parts of the circuit can be isolated. Only charge liquid refrigerant R-134a at the liquid line.

Ensure that you are using the correct refrigerant type before recharging the unit.

Charging any refrigerant other than the original charge type (R-134a) will impair machine operation and can even lead to a destruction of the compressors. The compressors operating with this refrigerant type are lubricated with a synthetic polyolester oil.



RISK OF EXPLOSION:

Do not use oxygen to purge lines or to pressurize a machine for any purpose. Oxygen gas reacts violently with oil, grease, and other common substances.

Never exceed the specified maximum operating pressures. Verify the allowable maximum high- and low-side test pressures by checking the instructions in this manual and the pressures given on the unit name plate.

Do not use air for leak testing. Use only refrigerant or dry nitrogen.

Do not unweld or flamecut the refrigerant lines or any refrigerant circuit component until all refrigerant (liquid and vapour) has been removed from chiller. Traces of vapour should be displaced with dry air nitrogen. Refrigerant in contact with an open flame produces toxic gases.

The necessary protection equipment must be available, and appropriate fire extinguishers for the system and the refrigerant type used must be within easy reach.

Do not siphon refrigerant.

1 - INTRODUCTION

Avoid contact with liquid refrigerant on the skin or splashing it into the eyes. Use safety goggles. Wash any spills from the skin with soap and water. If liquid refrigerant enters the eyes, immediately and abundantly flush the eyes with water and consult a doctor.

The accidental releases of the refrigerant, due to small leaks or significant discharges following the rupture of a pipe or an unexpected release from a relief valve, can cause frostbites and burns to personnel exposed. Do not ignore such injuries. Installers, owners and especially service engineers for these units must:

- Seek medical attention before treating such injuries.
- Have access to a first-aid kit, especially for treating eye injuries.

We recommend to apply standard EN 378-3 Annex 3.

Never apply an open flame or live steam to a refrigerant container. Dangerous overpressure can result. If it is necessary to heat refrigerant, use only warm water.

During refrigerant removal and storage operations follow applicable regulations. These regulations, permitting conditioning and recovery of halogenated hydrocarbons under optimum quality conditions for the products and optimum safety conditions for people, property and the environment are described in standard NF E29-795.

Any refrigerant transfer and recovery operations must be carried out using a transfer unit. A 3/8" SAE connector on the manual liquid line valve is supplied with all units for connection to the transfer station. The units must never be modified to add refrigerant and oil charging, removal and purging devices. All these devices are provided with the units. Please refer to the certified dimensional drawings for the units. Do not re-use disposable (non-returnable) cylinders or attempt to refill them. It is dangerous and illegal. When cylinders are empty, evacuate the remaining gas pressure, and move the cylinders to a place designated for their recovery. Do not incinerate.

ATTENTION: Only use refrigerant R134a, in accordance with 700 AHRI (Air conditioning, Heating and Refrigeration Institute). The use of any other refrigerant may expose users and operators to unexpected risks.

Do not attempt to remove refrigerant circuit components or fittings, while the machine is under pressure or while it is running. Be sure pressure is at 0 kPa before removing components or opening a circuit.

Do not attempt to repair or recondition any safety devices when corrosion or build-up of foreign material (rust, dirt, scale, etc.) is found within the valve body or mechanism. If necessary, replace the device. Do not install relief valves in series or backwards.

ATTENTION: No part of the unit must be used as a walk-way, rack or support. Periodically check and repair or if necessary replace any component or piping that shows signs of damage.

The refrigerant lines can break under the weight and release refrigerant, causing personal injury.

Do not climb on a machine. Use a platform, or staging to work at higher levels.

Use mechanical lifting equipment (crane, hoist, winch, etc.) to lift or move heavy components. For lighter components, use lifting equipment when there is a risk of slipping or losing your balance.

Use only original replacement parts for any repair or component replacement. Consult the list of replacement parts that corresponds to the specification of the original equipment.

Do not drain water circuits containing industrial brines, without informing the technical service department at the installation site or a competent body first.

Close the entering and leaving water shutoff valves and purge the unit water circuit, before working on the components installed on the circuit (screen filter, pump, water flow switch, etc.).

Do not loosen the water box bolts until the water boxes have been completely drained.

Periodically inspect all valves, fittings and pipes of the refrigerant and hydraulic circuits to ensure that they do not show any corrosion or any signs of leaks.

It is recommended to wear ear defenders, when working near the unit and the unit is in operation.

2 - PRELIMINARY CHECKS

2.1 - Check equipment received

- Inspect the unit for damage or missing parts. If damage is detected, or if shipment is incomplete, immediately file a claim with the shipping company.
- Confirm that the unit received is the one ordered. Compare the name plate data with the order.
- The unit name plate must include the following information:
 - Version number
 - Model number
 - CE marking
 - Serial number
 - Year of manufacture and test date
 - Fluid being transported
 - Refrigerant used and refrigerant class
 - Refrigerant charge per circuit
 - Containment fluid to be used
 - PS: Min./max. allowable pressure (high and low pressure side)
 - TS: Min./max. allowable temperature (high and low pressure side)
 - Pressure switch cut-out pressures
 - Unit leak test pressure
 - Voltage, frequency, number of phases
 - Maximum current drawn
 - Maximum power input
 - Unit net weight
- Confirm that all accessories ordered for on-site installation have been delivered, and are complete and undamaged.

The unit must be checked periodically during its whole operating life to ensure that no shocks (handling accessories, tools etc.) have damaged it. If necessary, the damaged parts must be repaired or replaced. See also chapter 13 "Standard maintenance".

2.2 - Moving and siting the unit

2.2.1 - Moving

See chapter 1.1 "Installation safety considerations".

CAUTION: Only use slings at the designated lifting points which are marked on the unit.

2.2.2 - Siting the unit

Always refer to the chapter "Dimensions and clearances" to confirm that there is adequate space for all connections and service operations. For the centre of gravity coordinates, the position of the unit mounting holes, and the weight distribution points, refer to the certified dimensional drawing supplied with the unit.

Typical applications of these units are in refrigeration systems, and they do not require earthquake resistance. Earthquake resistance has not been verified.

Before siting the unit check that:

- the permitted loading at the site is adequate or that appropriate strengthening measures have been taken.
- the unit is installed level on an even surface (maximum tolerance is 5 mm in both axes).
- there is adequate space above the unit for air flow and to ensure access to the components.
- the number of support points is adequate and that they are in the right places.
- the location is not subject to flooding.

CAUTION: Lift and set down the unit with great care. Tilting and jarring can damage the unit and impair unit operation.

2.2.3 - Checks before system start-up

Before the start-up of the refrigeration system, the complete installation, including the refrigeration system must be verified against the installation drawings, dimensional drawings, system piping and instrumentation diagrams and the wiring diagrams.

During the installation test national regulations must be followed. If no national regulation exists, standard EN 378 can be used as a guide.

External visual installation checks:

- Ensure that the machine is charged with refrigerant. Verify on the unit nameplate that the 'fluid being transported' is R-134a and is not nitrogen.
- Compare the complete installation with the refrigeration system and power circuit diagrams.
- Check that all components comply with the design specifications.
- Check that all protection documents and equipment provided by the manufacturer (dimensional drawings, P&ID, declarations etc.) to comply with the regulations are present.
- Verify that the environmental safety and protection and devices and arrangements provided by the manufacturer to comply with the regulations are in place.
- Verify that all document for pressure containers, certificates, name plates, files, instruction manuals provided by the manufacturer to comply with the regulations are present.
- Verify the free passage of access and safety routes.
- Check that ventilation in the plant room is adequate.
- Check that refrigerant detectors are present.
- Verify the instructions and directives to prevent the deliberate removal of refrigerant gases that are harmful to the environment.
- Verify the installation of connections.
- Verify the supports and fixing elements (materials, routing and connection).
- Verify the quality of welds and other joints.
- Check the protection against mechanical damage.
- Check the protection against heat.
- Check the protection of moving parts.
- Verify the accessibility for maintenance or repair and to check the piping.
- Verify the status of the valves.
- Verify the quality of the thermal insulation and of the vapour barriers.

3 - DIMENSIONS, CLEARANCES

3.1 - 30XW--/30XWH- 254-852 – 30XW-P/30XWHP 512-862

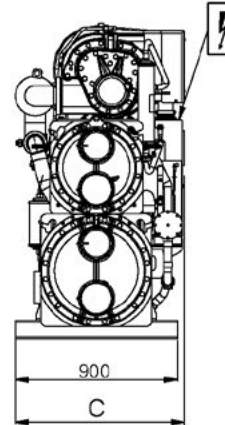
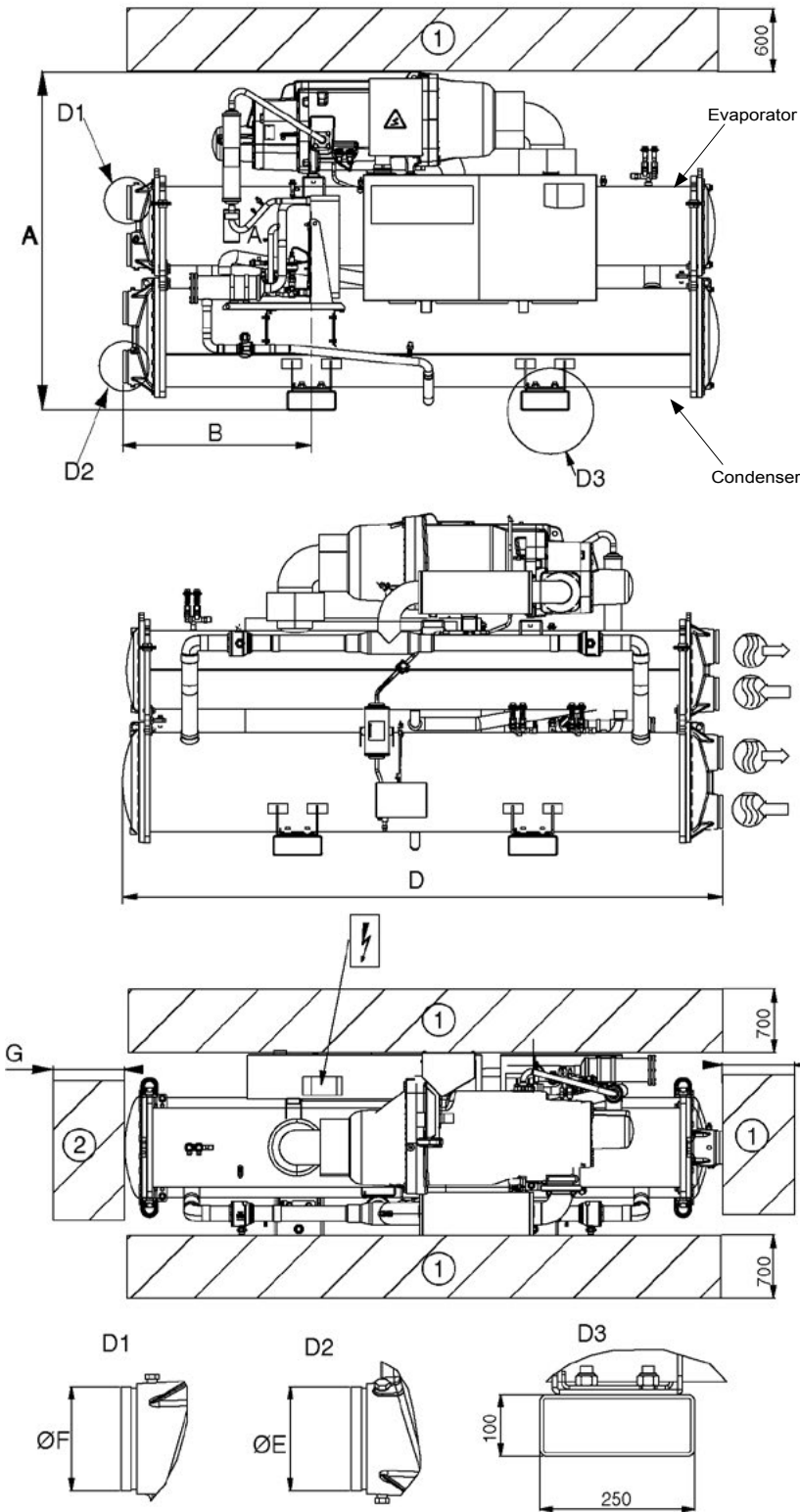

Dimensions in mm							
	A	B	C	D	E	F	G
Standard-efficiency units 30XW--/30XWH-							
254	1567	800	928	2724	141,3	141,3	2600
304	1567	800	928	2724	141,3	141,3	2600
354	1567	800	928	2724	141,3	141,3	2600
402	1693	810	936	2742	141,3	141,3	2600
452	1693	810	936	2742	141,3	141,3	2600
552	1693	810	936	2742	141,3	141,3	2600
602	1693	810	936	2742	141,3	141,3	2600
652	1848	968	1044	3059	168,3	168,3	2800
702	1848	968	1044	3059	168,3	168,3	2800
802	1848	968	1044	3059	168,3	168,3	2800
852	1898	828	1044	2780	219,1	168,3	2600
High-efficiency units 30XW-P/30XWHP							
512	1743	968	936	3059	168,3	168,3	2800
562	1743	968	936	3059	168,3	168,3	2800
712	1950	1083	1065	3290	219,1	219,1	3100
812	1950	1083	1070	3290	219,1	219,1	3100
862	1950	1083	1070	3290	219,1	219,1	3100
Standard-efficiency units 30XW--/30XWH- (option 150)							
254	1567	800	928	2724	141,3	141,3	2600
304	1567	800	928	2724	141,3	141,3	2600
354	1567	800	928	2724	141,3	141,3	2600
402	1693	810	936	2742	141,3	141,3	2600
452	1693	810	936	2742	141,3	141,3	2600
552	1693	810	936	2742	141,3	141,3	2600
602	1693	810	936	2742	141,3	141,3	2600
652	1868	968	1090	3059	168,3	168,3	2800
702	1868	968	1090	3059	168,3	168,3	2800
802	1868	968	1090	3059	168,3	168,3	2800
852	1920	828	1090	2780	168,3	219,1	2600
High-efficiency units 30XW-P/30XWHP (option 150)							
512	1743	968	936	3059	168,3	168,3	2800
562	1743	968	936	3059	168,3	168,3	2800
712	1970	1083	1105	3290	219,1	219,1	3100
812	1970	1083	1105	3290	219,1	219,1	3100
862	1970	1083	1105	3290	219,1	219,1	3100

NOTES:

- Drawings are not contractually binding. Before designing an installation, consult the certified dimensional drawings supplied with the unit or available on request.
- For the positioning of the fixing points, weight distribution and centre of gravity coordinates please refer to the dimensional drawings.
- Option 6 has same dimensions as option 150.
- Option 20 (IP44) has same dimensions as option 150 on units 652, 712, 802, 852, 862. Option 20 has same dimensions as standard on the other units.

Legend:

All dimensions are given in mm.

- ① Required clearances for maintenance
- ② Recommended space for tube removal
- Water inlet
- Water outlet
- Power supply connection

3 - DIMENSIONS, CLEARANCES

3.2 - 30XW--/30XWH- 1002-1552 – 30XW-P/30XWHP 1012-1464

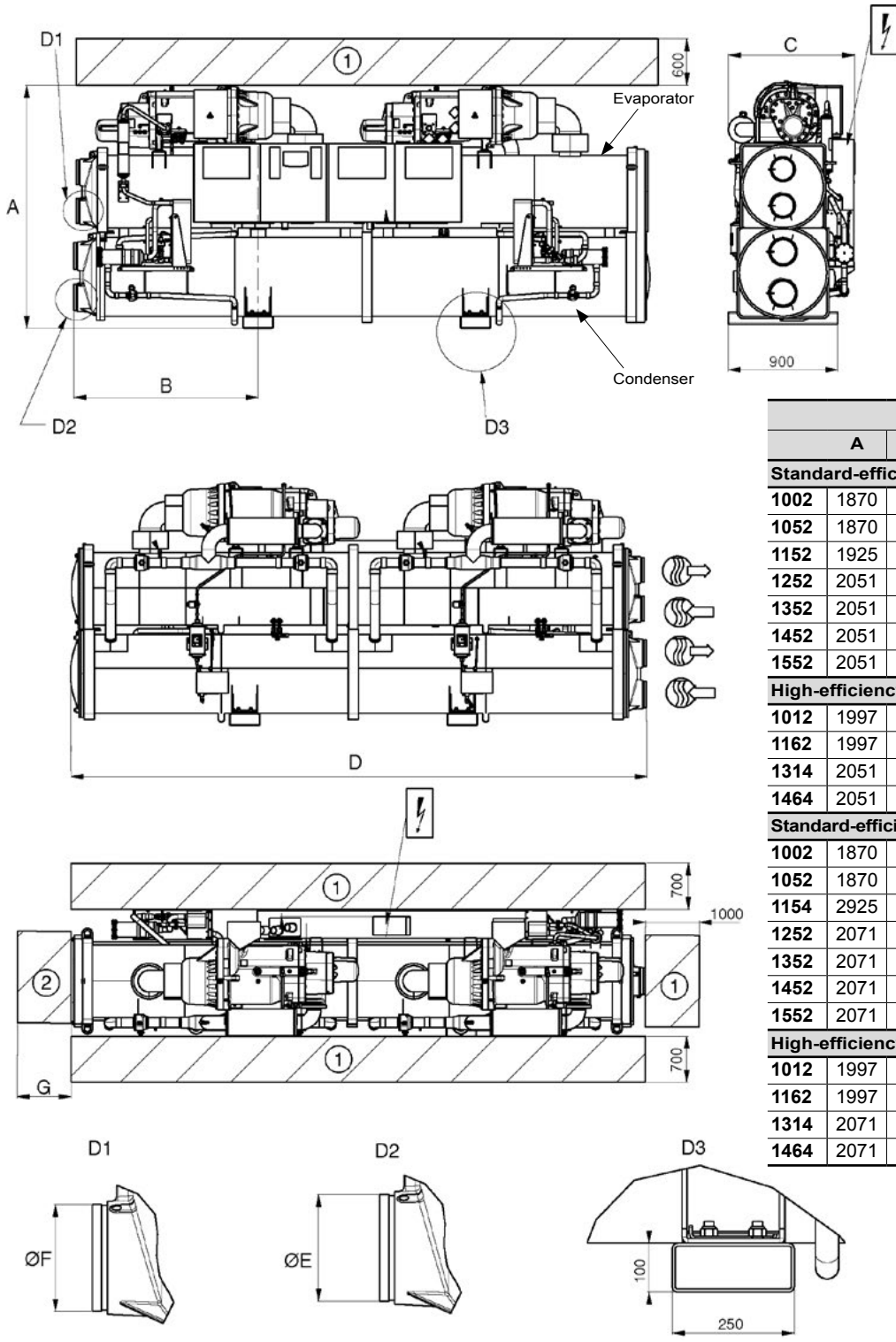

Dimensions in mm							
	A	B	C	D	E	F	G
Standard-efficiency units 30XW--/30XWH-							
1002	1870	950	1036	4025	219,1	168,3	3800
1052	1870	950	1036	4025	219,1	168,3	3800
1152	1925	950	1036	4025	219,1	219,1	3800
1252	2051	1512	1162	4730	219,1	219,1	4500
1352	2051	1512	1162	4730	219,1	219,1	4500
1452	2051	1512	1162	4730	219,1	219,1	4500
1552	2051	1512	1162	4730	219,1	219,1	4500
High-efficiency units 30XW-P/30XWHP							
1012	1997	1512	1039	4730	219,1	219,1	4500
1162	1997	1512	1039	4730	219,1	219,1	4500
1314	2051	1512	1162	4730	219,1	219,1	4500
1464	2051	1512	1162	4730	219,1	219,1	4500
Standard-efficiency units 30XW--/30XWH- (option 150)							
1002	1870	950	1036	4025	219,1	168,3	3800
1052	1870	950	1036	4025	219,1	168,3	3800
1154	2925	950	1036	4025	219,1	219,1	3800
1252	2071	1512	1202	4730	219,1	219,1	4500
1352	2071	1512	1202	4730	219,1	219,1	4500
1452	2071	1512	1202	4730	219,1	219,1	4500
1552	2071	1512	1202	4730	219,1	219,1	4500
High-efficiency units 30XW-P/30XWHP (option 150)							
1012	1997	1512	1039	4730	219,1	219,1	4500
1162	1997	1512	1039	4730	219,1	219,1	4500
1314	2071	1512	1202	4730	219,1	219,1	4500
1464	2071	1512	1202	4730	219,1	219,1	4500

NOTES:

- Drawings are not contractually binding. Before designing an installation, consult the certified dimensional drawings supplied with the unit or available on request.
- For the positioning of the fixing points, weight distribution and centre of gravity coordinates please refer to the dimensional drawings.
- Option 6 has same dimensions as option 150.
- Option 20 (IP44) has same dimensions as option 150 on units 652, 712, 802, 852, 862. Option 20 has same dimensions as standard on the other units.

Legend:

- All dimensions are given in mm.
- ① Required clearances for maintenance
- ② Recommended space for tube removal
- Water inlet
- Water outlet
- Power supply connection

3 - DIMENSIONS, CLEARANCES

3.3 - 30XW--/30XWH- 1652-1702 – 30XW-P/30XWHP 1612-1762

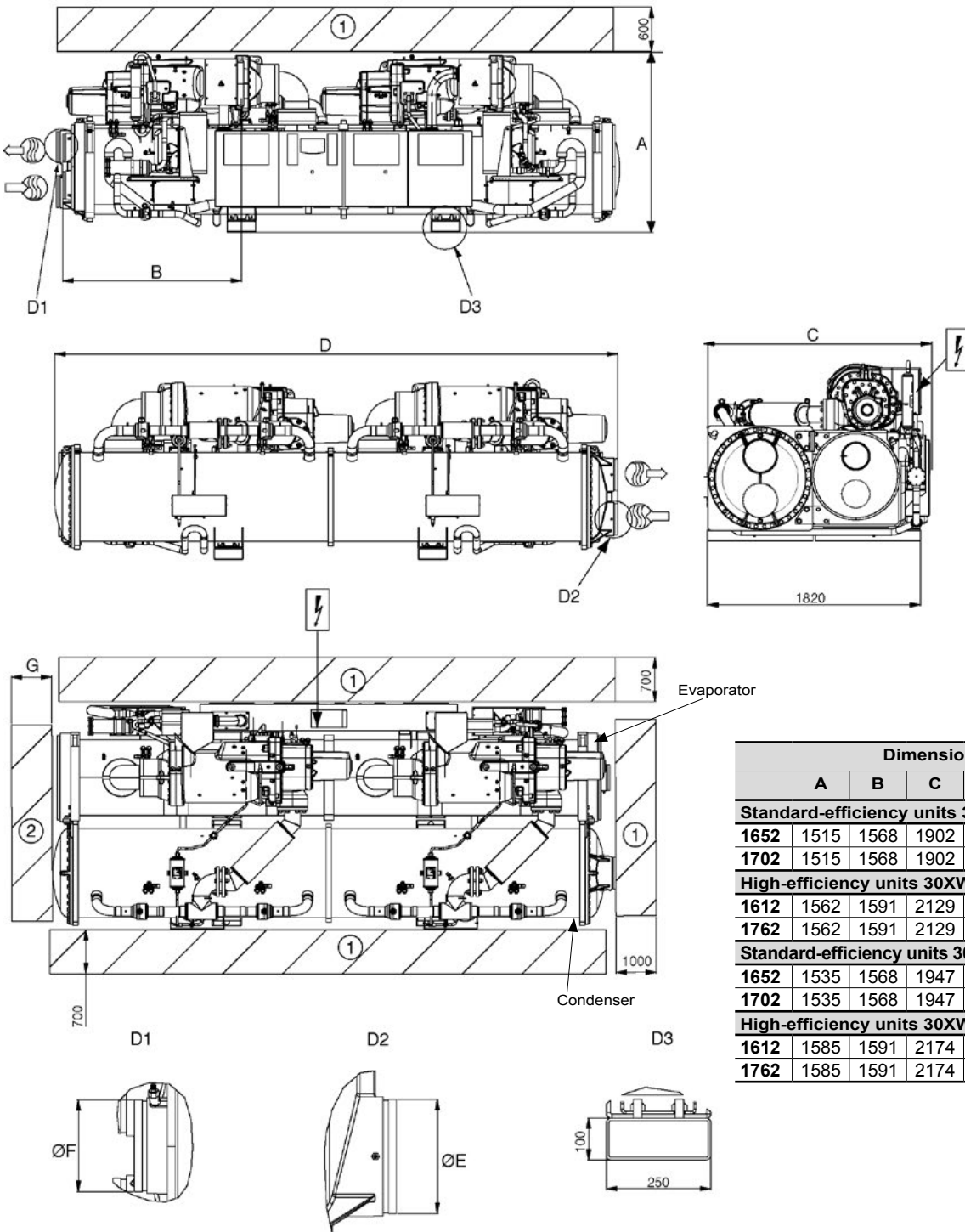

Dimensions in mm							
	A	B	C	D	E	F	G
Standard-efficiency units 30XW--/30XWH-							
1652	1515	1568	1902	4790	219,1	219,1	4500
1702	1515	1568	1902	4790	219,1	219,1	4500
High-efficiency units 30XW-P/30XWHP							
1612	1562	1591	2129	4832	273,1	273,1	4600
1762	1562	1591	2129	4832	273,1	273,1	4600
Standard-efficiency units 30XW--/30XWH- (option 150)							
1652	1535	1568	1947	4790	219,1	219,1	4500
1702	1535	1568	1947	4790	219,1	219,1	4500
High-efficiency units 30XW-P/30XWHP (option 150)							
1612	1585	1591	2174	4832	273,1	273,1	4600
1762	1585	1591	2174	4832	273,1	273,1	4600

NOTES:

- Drawings are not contractually binding. Before designing an installation, consult the certified dimensional drawings supplied with the unit or available on request.
- For the positioning of the fixing points, weight distribution and centre of gravity coordinates please refer to the dimensional drawings.
- Option 6 has same dimensions as option 150.
- Option 20 (IP44) has same dimensions as option 150 on units 652, 712, 802, 852, 862. Option 20 has same dimensions as standard on the other units.

Legend:

All dimensions are given in mm.

- ① Required clearances for maintenance
- ② Recommended space for tube removal
- ↻ Water inlet
- ↻ Water outlet
- ⚡ Power supply connection

4 - PHYSICAL AND ELECTRICAL DATA

4.1 - Physical data, units without options 150 and 6

■ Standard-efficiency units

30XW--/30XWH		254	304	354	402	452	552	602	652	702	802
Sound levels - standard unit											
Sound power level ⁽¹⁾	dB(A)	95	95	95	99	99	99	99	99	99	99
Sound pressure level at 1 m ⁽²⁾	dB(A)	78	78	78	82	82	82	82	82	82	82
Sound levels - standard unit + option 257⁽³⁾											
Sound power level ⁽¹⁾	dB(A)	-	-	-	96	96	96	96	96	96	96
Sound pressure level at 1 m ⁽²⁾	dB(A)	-	-	-	78	78	78	78	78	78	78
Dimensions - standard unit											
Length	mm	2724	2724	2724	2741	2741	2741	2741	3059	3059	3059
Width	mm	928	928	928	936	936	936	936	1040	1040	1040
Height	mm	1567	1567	1567	1692	1692	1692	1692	1848	1848	1848
Operating weight⁽⁴⁾	kg	2017	2036	2072	2575	2575	2613	2644	3247	3266	3282
Compressors Semi-hermetic 06T screw compressors, 50 r/s											
Circuit A		1	1	1	1	1	1	1	1	1	1
Circuit B		-	-	-	-	-	-	-	-	-	-
Refrigerant⁽⁴⁾ R-134a											
Circuit A	kg	84	80	78	92	92	92	92	145	135	125
	teqCO ₂	120	114	112	132	132	132	132	207	193	179
Circuit B	kg	-	-	-	-	-	-	-	-	-	-
	teqCO ₂	-	-	-	-	-	-	-	-	-	-
Oil - standard unit											
Circuit A	l	23,5	23,5	23,5	32	32	32	32	36	36	36
Circuit B	l	-	-	-	-	-	-	-	-	-	-
Capacity control SmartVu™, electronic expansion valves (EXV)											
Minimum capacity ⁽⁵⁾	%	15	15	30	30	30	30	30	15	15	30
Evaporator Multi-pipe flooded type											
Net water volume	l	50	56	61	70	70	70	70	109	109	109
Water connections (Victaulic)	in	5	5	5	5	5	5	5	6	6	6
Drain and vent connections (NPT)	in	3/8	3/8	3/8	3/8	3/8	3/8	3/8	3/8	3/8	3/8
Max. water-side operating pressure	kPa	1000	1000	1000	1000	1000	1000	1000	1000	1000	1000
Condenser Multi-pipe flooded type											
Net water volume	l	55	55	55	76	76	76	76	109	109	109
Water connections (Victaulic)	in	5	5	5	5	5	5	5	6	6	6
Drain and vent connections (NPT)	in	3/8	3/8	3/8	3/8	3/8	3/8	3/8	3/8	3/8	3/8
Max. water-side operating pressure	kPa	1000	1000	1000	1000	1000	1000	1000	1000	1000	1000

(1) In dB ref=10⁻¹² W, (A) weighting. Declared dualnumber noise emission values in accordance with ISO 4871 (with an associated uncertainty of +/-3dB(A)). Measured in accordance with ISO 9614-1 and certified by Eurovent.

(2) In dB ref 20µPa, (A) weighting. Declared dualnumber noise emission values in accordance with ISO 4871 (with an associated uncertainty of +/-3dB(A)). For information, calculated from the sound power level Lw(A).

(3) Option 257 = Low noise level.

(4) Weight shown is guideline only. Please refer to the unit nameplate.

(5) Minimum unit capacity corresponds to a physical state of the unit and is given for indication only. The actual capacity at this stage depends on operating conditions.



Eurovent certified values

4 - PHYSICAL AND ELECTRICAL DATA

■ Standard-efficiency units

30XW--/30XWH		852	1002	1052	1154	1252	1352	1452	1552	1652	1702
Sound levels - standard unit											
Sound power level ⁽¹⁾	dB(A)	99	102	102	102	102	102	102	102	102	102
Sound pressure level at 1 m ⁽²⁾	dB(A)	82	84	84	84	83	83	83	83	83	83
Sound levels - standard unit + option 257⁽³⁾											
Sound power level ⁽¹⁾	dB(A)	96	99	99	99	99	99	99	99	99	99
Sound pressure level at 1 m ⁽²⁾	dB(A)	78	80	80	80	80	80	80	80	80	80
Dimensions - standard unit											
Length	mm	2780	4025	4025	4025	4730	4730	4730	4730	4790	4790
Width	mm	1042	1036	1036	1036	1156	1156	1156	1156	1902	1902
Height	mm	1898	1870	1870	1925	2051	2051	2051	2051	1515	1515
Operating weight⁽⁴⁾	kg	3492	5370	5408	5698	7066	7267	7305	7337	8681	8699
Compressors Semi-hermetic 06T screw compressors, 50 r/s											
Circuit A		1	1	1	1	1	1	1	1	1	1
Circuit B		-	1	1	1	1	1	1	1	1	1
Refrigerant⁽⁴⁾ R-134a											
Circuit A	kg	158	85	85	105	120	115	110	105	195	195
	teqCO ₂	226	122	122	150	172	164	157	150	279	279
Circuit B	kg	-	85	85	105	120	115	110	105	195	195
	teqCO ₂	-	122	122	150	172	164	157	150	279	279
Oil - standard unit											
Circuit A	l	36	32	32	32	36	36	36	36	36	36
Circuit B	l	-	32	32	32	32	36	36	36	36	36
Capacity control SmartVu™, electronic expansion valves (EXV)											
Minimum capacity ⁽⁵⁾	%	30	30	30	30	15	15	15	30	30	30
Evaporator Multi-pipe flooded type											
Net water volume	l	98	182	182	205	301	301	301	301	354	354
Water connections (Victaulic)	in	6	6	6	8	8	8	8	8	8	8
Drain and vent connections (NPT)	in	3/8	3/8	3/8	3/8	3/8	3/8	3/8	3/8	3/8	3/8
Max. water-side operating pressure	kPa	1000	1000	1000	1000	1000	1000	1000	1000	1000	1000
Condenser Multi-pipe flooded type											
Net water volume	l	137	193	193	193	340	340	340	340	426	426
Water connections (Victaulic)	in	8	8	8	8	8	8	8	8	8	8
Drain and vent connections (NPT)	in	3/8	3/8	3/8	3/8	3/8	3/8	3/8	3/8	3/8	3/8
Max. water-side operating pressure	kPa	1000	1000	1000	1000	1000	1000	1000	1000	1000	1000

(1) In dB ref=10⁻¹² W, (A) weighting. Declared dualnumber noise emission values in accordance with ISO 4871 (with an associated uncertainty of +/-3dB(A)). Measured in accordance with ISO 9614-1 and certified by Eurovent.

(2) In dB ref 20μPa, (A) weighting. Declared dualnumber noise emission values in accordance with ISO 4871 (with an associated uncertainty of +/-3dB(A)). For information, calculated from the sound power level Lw(A).

(3) Option 257 = Low noise level.

(4) Weight shown is guideline only. Please refer to the unit nameplate.

(5) Minimum unit capacity corresponds to a physical state of the unit and is given for indication only. The actual capacity at this stage depends on operating conditions.



Eurovent certified values

4 - PHYSICAL AND ELECTRICAL DATA

■ High-efficiency units

30XW-P/30XWHP		512	562	712	812	862	1012	1162	1314	1464	1612	1762
Sound levels - standard unit												
Sound power level ⁽¹⁾	dB(A)	99	99	99	99	99	102	102	102	102	102	102
Sound pressure level at 1 m ⁽²⁾	dB(A)	82	82	81	81	81	83	83	83	83	83	83
Sound levels - standard unit + option 257⁽³⁾												
Sound power level ⁽¹⁾	dB(A)	96	96	96	96	96	99	99	99	99	99	99
Sound pressure level at 1 m ⁽²⁾	dB(A)	78	78	78	78	78	80	80	80	80	80	80
Dimensions - standard unit												
Length	mm	3059	3059	3290	3290	3290	4730	4730	4730	4730	4832	4832
Width	mm	936	936	1069	1069	1069	1039	1039	1162	1162	2129	2129
Height	mm	1743	1743	1950	1950	1950	1997	1997	2051	2051	1562	1562
Operating weight ⁽⁴⁾	kg	2981	3020	3912	3947	3965	6872	6950	7542	7752	10910	10946
Compressors												
Semi-hermetic 06T screw compressors, 50 r/s												
Circuit A		1	1	1	1	1	1	1	1	1	1	1
Circuit B		-	-	-	-	-	1	1	1	1	1	1
Refrigerant⁽⁴⁾												
R-134a												
Circuit A	kg	130	130	180	175	177	120	120	130	130	240	250
	teqCO ₂	186	186	257	250	253	172	172	186	186	343	358
Circuit B	kg	-	-	-	-	-	120	120	150	130	240	250
	teqCO ₂	-	-	-	-	-	172	172	215	186	343	358
Oil - standard unit												
Circuit A	l	32	32	36	36	36	32	32	36	36	36	36
Circuit B	l	-	-	-	-	-	32	32	32	36	36	36
Capacity control												
SmartVu™, electronic expansion valves (EXV)												
Minimum capacity ⁽⁵⁾	%	30	30	15	15	30	30	30	15	15	15	30
Evaporator												
Multi-pipe flooded type												
Net water volume	l	101	101	154	154	154	293	293	321	321	473	473
Water connections (Victaulic)	in	6	6	8	8	8	8	8	8	8	10	10
Drain and vent connections (NPT)	in	3/8	3/8	3/8	3/8	3/8	3/8	3/8	3/8	3/8	3/8	3/8
Max. water-side operating pressure	kPa	1000	1000	1000	1000	1000	1000	1000	1000	1000	1000	1000
Condenser												
Multi-pipe flooded type												
Net water volume	l	103	103	148	148	148	316	316	340	340	623	623
Water connections (Victaulic)	in	6	6	8	8	8	8	8	8	8	10	10
Drain and vent connections (NPT)	in	3/8	3/8	3/8	3/8	3/8	3/8	3/8	3/8	3/8	3/8	3/8
Max. water-side operating pressure	kPa	1000	1000	1000	1000	1000	1000	1000	1000	1000	1000	1000

(1) In dB ref=10⁻¹² W, (A) weighting. Declared dualnumber noise emission values in accordance with ISO 4871 (with an associated uncertainty of +/-3dB(A)). Measured in accordance with ISO 9614-1 and certified by Eurovent.

(2) In dB ref 20μPa, (A) weighting. Declared dualnumber noise emission values in accordance with ISO 4871 (with an associated uncertainty of +/-3dB(A)). For information, calculated from the sound power level Lw(A).

(3) Option 257 = Low noise level.

(4) Weight shown is guideline only. Please refer to the unit nameplate.

(5) Minimum unit capacity corresponds to a physical state of the unit and is given for indication only. The actual capacity at this stage depends on operating conditions.



Eurovent certified values

4 - PHYSICAL AND ELECTRICAL DATA

4.2 - Electrical data, units without options 150 and 6

■ Standard-efficiency units

30XW--/30XWH		254	304	354	402	452	552	602	652	702	802
Power circuit											
Nom. power supply	V-ph-Hz	400-3-50									
Voltage range	V	360-440									
Control circuit											
24 V via the built-in transformer											
Nominal start-up current⁽¹⁾											
Circuit A	A	233	233	303	414	414	414	414	587	587	587
Circuit B	A	-	-	-	-	-	-	-	-	-	-
Option 81	A	-	-	-	-	-	-	-	-	-	-
Maximum start-up current⁽²⁾											
Circuit A	A	233	233	303	414	414	414	414	587	587	587
Circuit B	A	-	-	-	-	-	-	-	-	-	-
Option 81	A	-	-	-	-	-	-	-	-	-	-
Cosine phi											
Nominal ⁽³⁾		0,83	0,85	0,83	0,87	0,88	0,89	0,89	0,88	0,89	0,90
Maximum ⁽⁴⁾		0,89	0,89	0,88	0,90	0,90	0,91	0,91	0,90	0,91	0,92
Total harmonic distortion ⁽⁴⁾	%	0	0	0	0	0	0	0	0	0	0
Maximum power input*											
Circuit A	kW	76	89	97	128	135	151	151	184	200	223
Circuit B	kW	-	-	-	-	-	-	-	-	-	-
Option 81	kW	-	-	-	-	-	-	-	-	-	-
Nominal current drawn⁽³⁾											
Circuit A	A	84	96	113	136	144	162	162	193	214	232
Circuit B	A	-	-	-	-	-	-	-	-	-	-
Option 81	A	-	-	-	-	-	-	-	-	-	-
Maximum current drawn (Un)*											
Circuit A	A	123	145	160	206	217	242	242	295	317	351
Circuit B	A	-	-	-	-	-	-	-	-	-	-
Option 81	A	-	-	-	-	-	-	-	-	-	-
Maximum current drawn (Un -10%)⁽⁴⁾											
Circuit A	A	138	162	178	218	230	260	260	304	340	358
Circuit B	A	-	-	-	-	-	-	-	-	-	-
Option 81	A	-	-	-	-	-	-	-	-	-	-
Maximum power input with option 150B*											
Circuit A	kW	67	79	87	114	118	133	134	173	183	205
Circuit B	kW	-	-	-	-	-	-	-	-	-	-
Option 81	kW	-	-	-	-	-	-	-	-	-	-
Maximum current drawn (Un) with option 150B*											
Circuit A	A	109	129	142	183	191	212	212	278	290	325
Circuit B	A	-	-	-	-	-	-	-	-	-	-
Option 81	A	-	-	-	-	-	-	-	-	-	-

(1) Instantaneous start-up current (maximum operating current of the smallest compressor(s) + locked rotor current or reduced start-up current of the largest compressor).

Values obtained at standard Eurovent conditions: evaporator entering/leaving water temp. = 12°C/7°C, condenser entering/leaving water temp. = 30°C/35°C.

(2) Instantaneous start-up current (maximum operating current of the smallest compressor(s) + locked rotor current or reduced start-up current of the largest compressor).

Values obtained at operation with maximum unit power input.

(3) Values obtained at standard Eurovent conditions: evaporator entering/leaving water temp. = 12°C/7°C, condenser entering/leaving water temp. = 30°C/35°C

(4) Values obtained at operation with maximum unit power input.

* Values obtained at operation with maximum unit power input. Values given on the unit name plate.

4 - PHYSICAL AND ELECTRICAL DATA

■ Standard-efficiency units

30XW--/30XWH		852	1002	1052	1154	1252	1352	1452	1552	1652	1702
Power circuit											
Nom. power supply	V-ph-Hz	400-3-50									
Voltage range	V	360-440									
Control circuit		24 V via the built-in transformer									
Nominal start-up current⁽¹⁾											
Circuit A	A	587	414	414	414	587	587	587	587	587	587
Circuit B	A	-	414	414	414	414	587	587	587	587	587
Option 81	A	-	558	574	574	747	780	801	819	819	819
Maximum start-up current⁽²⁾											
Circuit A	A	587	414	414	414	587	587	587	587	587	587
Circuit B	A	-	414	414	414	414	587	587	587	587	587
Option 81	A	-	631	656	656	829	882	904	938	938	938
Cosine phi											
Nominal ⁽³⁾		0,90	0,88	0,89	0,89	0,88	0,88	0,89	0,90	0,90	0,90
Maximum ⁽⁴⁾		0,92	0,90	0,91	0,91	0,90	0,90	0,91	0,92	0,92	0,92
Total harmonic distortion ⁽⁴⁾	%	0	0	0	0	0	0	0	0	0	0
Maximum power input*											
Circuit A	kW	223	150	151	151	184	184	200	223	223	223
Circuit B	kW	-	135	151	151	151	184	200	223	202	223
Option 81	kW	-	284	301	301	334	367	399	447	425	447
Nominal current drawn⁽³⁾											
Circuit A	A	232	162	162	162	193	193	214	232	232	232
Circuit B	A	-	144	162	162	162	193	214	232	214	232
Option 81	A	-	306	324	324	355	386	427	464	446	464
Maximum current drawn (Un)*											
Circuit A	A	351	242	242	242	295	295	317	351	351	351
Circuit B	A	-	217	242	242	242	295	317	351	317	351
Option 81	A	-	459	484	484	537	590	634	702	668	702
Maximum current drawn (Un -10%)⁽⁴⁾											
Circuit A	A	358	260	260	260	304	304	340	358	358	358
Circuit B	A	-	230	260	260	260	304	340	358	340	358
Option 81	A	-	490	520	520	564	608	680	716	698	716
Maximum power input with option 150B*											
Circuit A	kW	205	133	133	133	173	173	183	207	207	207
Circuit B	kW	-	118	133	133	133	173	183	207	185	207
Option 81	kW	-	251	265	265	305	346	365	414	391	414
Maximum current drawn (Un) with option 150B*											
Circuit A	A	325	212	212	212	278	278	290	325	325	325
Circuit B	A	-	191	212	212	212	278	290	325	290	325
Option 81	A	-	403	424	424	490	556	580	650	615	650

(1) Instantaneous start-up current (maximum operating current of the smallest compressor(s) + locked rotor current or reduced start-up current of the largest compressor).

Values obtained at standard Eurovent conditions: evaporator entering/leaving water temp. = 12°C/7°C, condenser entering/leaving water temp. = 30°C/35°C.

(2) Instantaneous start-up current (maximum operating current of the smallest compressor(s) + locked rotor current or reduced start-up current of the largest compressor).

Values obtained at operation with maximum unit power input.

(3) Values obtained at standard Eurovent conditions: evaporator entering/leaving water temp. = 12°C/7°C, condenser entering/leaving water temp. = 30°C/35°C

(4) Values obtained at operation with maximum unit power input.

* Values obtained at operation with maximum unit power input. Values given on the unit name plate.

4 - PHYSICAL AND ELECTRICAL DATA

■ High-efficiency units

30XW-P/30XWHP		512	562	712	812	862	1012	1162	1314	1464	1612	1762
Power circuit												
Nominal power supply	V-ph-Hz	400-3-50										
Voltage range	V	360-440										
Control circuit												
24 V via the built-in transformer												
Nominal start-up current⁽¹⁾												
Circuit A	A	414	414	587	587	587	414	414	587	587	587	587
Circuit B	A	-	-	-	-	-	414	414	414	587	587	587
Option 81	A	-	-	-	-	-	556	574	747	780	801	819
Maximum start-up current⁽²⁾												
Circuit A	A	414	414	587	587	587	414	414	587	587	587	587
Circuit B	A	-	-	-	-	-	414	414	414	587	587	587
Option 81	A	-	-	-	-	-	631	656	829	882	904	938
Cosine phi												
Nominal ⁽³⁾		0,88	0,89	0,88	0,89	0,90	0,86	0,87	0,88	0,88	0,89	0,90
Maximum ⁽⁴⁾		0,90	0,90	0,90	0,91	0,92	0,89	0,90	0,90	0,90	0,91	0,92
Total harmonic distortion ⁽⁴⁾	%	0	0	0	0	0	0	0	0	0	0	0
Maximum power input*												
Circuit A	kW	135	151	184	200	223	134	151	184	184	200	223
Circuit B	kW	-	-	-	-	-	134	151	151	184	200	223
Option 81	kW	-	-	-	-	-	267	301	334	367	399	447
Nominal current drawn⁽³⁾												
Circuit A	A	144	162	193	214	232	144	162	193	193	214	232
Circuit B	A	-	-	-	-	-	144	162	162	193	214	232
Option 81	A	-	-	-	-	-	288	324	355	386	427	464
Maximum current drawn (Un)*												
Circuit A	A	217	242	295	317	351	217	242	295	295	317	351
Circuit B	A	-	-	-	-	-	217	242	242	295	317	351
Option 81	A	-	-	-	-	-	434	484	537	590	634	702
Maximum current drawn (Un -10%)⁽⁴⁾												
Circuit A	A	230	260	304	340	358	230	260	304	304	340	358
Circuit B	A	-	-	-	-	-	230	260	260	304	340	358
Option 81	A	-	-	-	-	-	460	520	564	608	680	716
Maximum power input with option 150B*												
Circuit A	kW	118	133	173	183	207	118	133	173	173	183	207
Circuit B	kW	-	-	-	-	-	118	133	133	173	183	207
Option 81	kW	-	-	-	-	-	235	265	305	346	365	414
Maximum current drawn (Un) with option 150B*												
Circuit A	A	191	212	278	290	325	191	212	278	278	290	325
Circuit B	A	-	-	-	-	-	191	212	212	278	290	325
Option 81	A	-	-	-	-	-	382	424	490	556	580	650

(1) Instantaneous start-up current (maximum operating current of the smallest compressor(s) + locked rotor current or reduced start-up current of the largest compressor).

Values obtained at standard Eurovent conditions: evaporator entering/leaving water temp. = 12°C/7°C, condenser entering/leaving water temp. = 30°C/35°C.

(2) Instantaneous start-up current (maximum operating current of the smallest compressor(s) + locked rotor current or reduced start-up current of the largest compressor).

Values obtained at operation with maximum unit power input.

(3) Values obtained at standard Eurovent conditions: evaporator entering/leaving water temp. = 12°C/7°C, condenser entering/leaving water temp. = 30°C/35°C

(4) Values obtained at operation with maximum unit power input.

* Values obtained at operation with maximum unit power input. Values given on the unit name plate.

4 - PHYSICAL AND ELECTRICAL DATA

4.3 - Short-circuit stability current for all units

Short-circuit stability current for all units using the TN system (earthing system type): 50 kA (conditional system short-circuit current Icc/Icf at the unit connection point as rms value).

All units are equipped with protection fuses located in the control box immediately downstream from the unit connection point.

4.4 - Compressor electrical data 30XW

Compressor	I Nom (A) ⁽¹⁾	I Max (A) ⁽²⁾	I Max (A) ⁽²⁾ Option 150B	MHA (A)	LRYA (A)	LRDA (A)	Cosine phi nom. ⁽¹⁾	Cosine phi max. ⁽²⁾
06TTW266	84	123	109	138	233	725	0,83	0,89
06TTW301	96	145	129	162	233	725	0,85	0,89
06TTW356	113	160	142	178	303	945	0,83	0,88
06TUA483	144	217	191	230	414	1290	0,88	0,9
06TUA554	162	242	212	260	414	1290	0,89	0,9
06TVW680	193	295	278	304	587	1828	0,88	0,9
06TVW753	214	317	290	340	587	1828	0,89	0,91
06TVW819	232	351	325	358	587	1828	0,9	0,91
06TTA266	95	160	125	176	303	945	0,79	0,88
06TTA301	109	185	144	206	388	1210	0,78	0,87
06TTA356	125	200	156	224	388	1210	0,81	0,88
06TUA483	162	275	215	300	587	1828	0,85	0,91
06TUA554	171	300	234	330	587	1828	0,85	0,91
06TVA680	210	400	312	419	629	1919	0,85	0,90
06TVA753	230	430	335	455	629	1919	0,86	0,90
06TVA819	250	460	359	476	629	1919	0,87	0,90

(1) Value at standard Eurovent conditions: evaporator entering/leaving water temperature = 12°C/7°C, condenser entering/leaving water temperature = 30°C/35°C.

(2) Value at maximum capacity and nominal voltage (400 V)

Legend

- MHA - Maximum compressor operating current, limited by the unit (current given for maximum capacity at 360 V)
- LRYA - Locked rotor current for star connection (connection during compressor start-up)
- LRDA - Locked rotor current for delta connection

4.5 - Compressor usage per circuit (A, B)

30XW	254	304	354	402 452 512	552 562 602	652 712	702 812	802 852 862	1002	1012	1052 1154 1162	1252 1314	1352 1464	1452 1612	1552 1702 1762	1652
Units without option 150																
06TTW266	A	-	-	-	-	-	-	-	-	-	-	-	-	-	-	-
06TTW301	-	A	-	-	-	-	-	-	-	-	-	-	-	-	-	-
06TTW356	-	-	A	-	-	-	-	-	-	-	-	-	-	-	-	-
06TUA483	-	-	-	A	-	-	-	-	B	AB	-	-	-	-	-	-
06TUA554	-	-	-	-	A	-	-	-	A	-	AB	B	-	-	-	-
06TVW680	-	-	-	-	-	A	-	-	-	-	-	A	AB	-	-	-
06TVW753	-	-	-	-	-	-	A	-	-	-	-	-	-	AB	-	B
06TVW819	-	-	-	-	-	-	-	A	-	-	-	-	-	-	AB	A
Units with option 150																
06TTA266	A	-	-	-	-	-	-	-	-	-	-	-	-	-	-	-
06TTA301	-	A	-	-	-	-	-	-	-	-	-	-	-	-	-	-
06TTA356	-	-	A	-	-	-	-	-	-	-	-	-	-	-	-	-
06TUA483	-	-	-	A	-	-	-	-	B	AB	-	-	-	-	-	-
06TUA554	-	-	-	-	A	-	-	-	A	-	AB	B	-	-	-	-
06TVA680	-	-	-	-	-	A	-	-	-	-	-	A	AB	-	-	-
06TVA753	-	-	-	-	-	-	A	-	-	-	-	-	-	AB	-	B
06TVA819	-	-	-	-	-	-	-	A	-	-	-	-	-	-	AB	A

4 - PHYSICAL AND ELECTRICAL DATA

Electrical data notes and operating conditions, 30XW units

- As standard:
30XW 254 to 862 units have a single power connection point located immediately upstream of the main disconnect switch.
30XW 1002 to 1762 units have two connection points located immediately upstream of the main disconnect switches.
- The control box includes the following standard features:
 - One main disconnect switch per circuit⁽¹⁾
 - Starter and motor protection devices for each compressor
 - Anti-short cycle protection devices⁽¹⁾
 - Control devices
- Field connections:
All connections to the system and the electrical installations must be in full accordance with all applicable codes.
- The Carrier 30XW units are designed and built to ensure conformance with local codes. The recommendations of European standard EN 60204-1 (corresponds to IEC 60204-1) (machine safety - electrical machine components - part 1: general regulations) are specifically taken into account, when designing the electrical equipment.
- The absence of power supply disconnect switch(es) and short-cycle protection devices in option 82A is an important factor that has to be taken into consideration at the installation site.
Units equipped with one of these two options are supplied with a declaration of incorporation, as required by the machinery directive.

Notes:

- Generally the recommendations of IEC 60364 are accepted as compliance with the requirements of the installation directives. Conformance with EN 60204-1 is the best means of ensuring compliance with the Machines Directive.
- Annex B of EN 60204 1 describes the electrical characteristics used for the operation of the machines.

1. The operating environment for the 30XW units is specified below:
 - Environment⁽²⁾ Environment as classified in EN 60721 (corresponds to IEC 60721):
 - indoor installation
 - ambient temperature range: minimum temperature +5°C to +42°C, class AA4
 - altitude: lower than or equal to 2000 m
 - presence of water: class AD2 (possibility of water droplets)
 - presence of hard solids, class 4S2 (no significant dust present)
 - presence of corrosive and polluting substances, class 4C2 (negligible)
 - personal skills: BA4 (informed person)
2. Power supply frequency variation: ± 2 Hz.
3. The neutral (N) line must not be connected directly to the unit (if necessary use a transformer).
4. Overcurrent protection of the power supply conductors is not provided with the unit.
5. The factory installed disconnect switch(es)/circuit breaker(s) is (are) of a type suitable for power interruption in accordance with EN 60947-3 (corresponds to IEC 60947-3).
6. The units are designed for connection to TN networks (IEC 60364). For IT networks the earth connection must not be at the network earth. Provide a local earth, consult competent local organisations to complete the electrical installation.

NOTE: If particular aspects of an actual installation do not conform to the conditions described above, or if there are other conditions which should be considered, always contact your local Carrier representative.

(1) Not provided for units equipped with option 82A

(2) The required protection level for this class is IP21B or IPX1B (according to reference standard IEC 60529). All 30XW units fulfil this protection condition. In general the casings fulfil class IP23 or IPX3B.

5 - ELECTRICAL CONNECTION

Please refer to the certified dimensional drawings, supplied with the unit.

5.1 - Power supply

The power supply must conform to the specification on the unit nameplate. The supply voltage must be within the range specified in the electrical data table. For connection details refer to the wiring diagrams.

WARNING: Operation of the unit with an improper supply voltage or excessive phase imbalance constitutes abuse which will invalidate the Carrier warranty. If the phase imbalance exceeds 2% for voltage, or 10% for current, contact your local electricity supplier at once and ensure that the unit is not switched on until corrective measures have been taken.

5.2 - Voltage phase imbalance (%)

$$\frac{100 \times \text{max. deviation from average voltage}}{\text{Average voltage}}$$

Example:

On a 400 V - 3 ph - 50 Hz supply, the individual phase voltages were measured to be:

AB = 406 V; BC = 399 V; AC = 394 V

Average voltage = $(406 + 399 + 394)/3 = 1199/3 = 399.7$ say 400 V

Calculate the maximum deviation from the 400 V average:

(AB) = 406 - 400 = 6

(BC) = 400 - 399 = 1

(CA) = 400 - 394 = 6

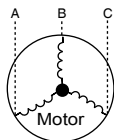

The maximum deviation from the average is 6 V. The greatest percentage deviation is: $100 \times 6/400 = 1.5\%$. This is less than the permissible 2% and is therefore acceptable.

5.3 - Power connection/disconnect switch

Units	Connection points
30XW 252-862	1 per unit
30XW 1002-1762	1 for circuit A 1 for circuit B

5.4 - Recommended wire sections

Wire sizing is the responsibility of the installer, and depends on the characteristics and regulations applicable to each installation site. The following is only to be used as a guide-line, and does not make in any way liable. After wire sizing has been completed, using the certified dimensional drawing, the installer must ensure easy connection and define any modifications necessary on site.

The connections provided as standard for the field-supplied power entry cables to the general disconnect/isolator switch are designed for the number and type of wires, listed in the second column of the table on the next page.

The calculations for favourable and unfavourable cases are based on the maximum current for each unit (see electrical data tables). The design uses the standardised installation methods in accordance with IEC 60364: multiconductor PVC (70°C) or XLPE (90°C) insulated cables with copper core; arrangement to comply with table 52c of the above standard. The maximum temperature is 42°C. The given maximum length is calculated to limit the voltage drop to 5%.

Minimum and maximum connectable wire sections for 30XW units

30XW - Circuit(s) A/(B)	Connectable wire section ⁽¹⁾ Section mm ² (per phase)	Calculation favourable case: Perforated horizontal conduit (standardised routing No. 15) XLPE insulated cable			Calculation unfavourable case: Closed conduit (standardised routing No. 41) PVC insulated cable, if possible		
		Section ⁽²⁾ mm ² (per phase)	Max. length m	Cable type	Section ⁽²⁾ mm ² (per phase)	Max. length m	Cable type ⁽³⁾
Units without option 150 or 81							
254 - 304	1 x 150	1 x 50	160	XLPE Cu	1 x 95	310	PVC Cu
354	1 x 240	1 x 70	220	XLPE Cu	1 x 95	350	PVC Cu
402	1 x 240	1 x 70	170	XLPE Cu	1 x 150	350	PVC Cu
452 - 512	1 x 240	1 x 95	230	XLPE Cu	1 x 185	390	PVC Cu
552 - 562 - 602	1 x 240	1 x 95	275	XLPE Cu	1 x 185	360	PVC Cu
652 - 712	1 x 240	1 x 120	210	XLPE Cu	1 x 240	380	PVC Cu
702 - 812	1 x 240	1 x 150	230	XLPE Cu	1 x 240	330	XLPE Cu
802 - 852 - 862	1 x 240	1 x 150	217	XLPE Cu	1 x 240	320	XLPE Cu
1002	2 x 240/2 x 240	1 x 95/1 x 95	200/200	XLPE Cu	1 x 240/1 x 240	400/400	PVC Cu
1012	2 x 240/2 x 240	1 x 120/1 x 95	230/200	XLPE Cu	1 x 240/1 x 240	400/401	PVC Cu
1052 - 1154 - 1162	2 x 240/2 x 240	1 x 120/1 x 120	220/220	XLPE Cu	2 x 120/2 x 120	375/375	PVC Cu
1252 - 1314	2 x 240/2 x 240	1 x 150/1 x 120	220/220	XLPE Cu	2 x 185/2 x 120	410/375	PVC Cu
1352 - 1464	2 x 240/2 x 240	1 x 150/1 x 150	220/220	XLPE Cu	2 x 185/2 x 185	410/410	PVC Cu
1452 - 1612	2 x 240/2 x 240	1 x 185/1 x 185	230/230	XLPE Cu	2 x 185/2 x 185	370/370	PVC Cu
1552 - 1702 - 1762	2 x 240/2 x 240	1 x 185/1 x 185	220/220	XLPE Cu	2 x 240/2 x 240	400/400	PVC Cu
1652	2 x 240/2 x 240	1 x 185/1 x 185	220/230	XLPE Cu	2 x 240/2 x 185	400/400	PVC Cu

(1) Connection capacities actually available for each machine, defined according to the connection terminal size, the control box access opening size and the available space inside the control box.

(2) Selection simulation result considering the hypothesis indicated.

(3) If the maximum calculated section is for an XLPE cable type, this means that a selection based on a PVC cable type can exceed the connection capacity actually available. Special attention must be given to the selection.

Note: The currents considered are given for a machine equipped with a hydraulic module operating at maximum current.

5 - ELECTRICAL CONNECTION

Minimum and maximum connectable wire sections for 30XW units

30XW - Circuit(s) A/(B)	Connectable wire section ⁽¹⁾	Calculation favourable case: Perforated horizontal conduit (standardised routing No. 15) XLPE insulated cable			Calculation unfavourable case: Closed conduit (standardised routing No. 41) PVC insulated cable, if possible		
	Section mm ² (per phase)	Section ⁽²⁾ mm ² (per phase)	Max. length m	Cable type	Section ⁽²⁾ mm ² (per phase)	Max. length m	Cable type ⁽³⁾
Units with option 150							
254 - 304	1 x 240	1 x 70	190	XLPE Cu	1 x 150	370	PVC Cu
354	1 x 240	1 x 70	170	XLPE Cu	1 x 185	400	PVC Cu
402	1 x 240	1 x 95	190	XLPE Cu	1 x 240	420	PVC Cu
452 - 512	1 x 240	1 x 120	210	XLPE Cu	1 x 185	290	PVC Cu
552 - 562 - 602	1 x 240	1 x 120	210	XLPE Cu	1 x 240	340	XLPE Cu
652 - 712	2 x 240	1 x 240	275	XLPE Cu	2 x 150	320	XLPE Cu
702 - 812	2 x 240	1 x 240	250	XLPE Cu	2 x 150	300	XLPE Cu
802 - 852 - 862	2 x 240	2 x 240	240	XLPE Cu	2 x 150	280	XLPE Cu
1002	2 x 240/2 x 240	1 x 150/1 x 150	220/230	XLPE Cu	2 x 150/2 x 150	310/340	PVC Cu
1012	2 x 240/2 x 240	1 x 150/1 x 150	220/220	XLPE Cu	2 x 185/2 x 185	410/410	XLPE Cu
1052 - 1154 - 1162	2 x 240/2 x 240	1 x 150/1 x 150	210/210	XLPE Cu	2 x 185/2 x 185	400/400	PVC Cu
1252 - 1314	2 x 240/2 x 240	1 x 240/1 x 150	240/210	XLPE Cu	2 x 185/2 x 185	310/400	XLPE Cu/PVC Cu
1352 - 1464	2 x 240/2 x 240	1 x 240/1 x 240	240/240	XLPE Cu	2 x 185/2 x 185	310/310	XLPE Cu
1452 - 1612	2 x 240/2 x 240	2 x 120/2 x 120	220/220	XLPE Cu	2 x 240/2 x 185	320/310	XLPE Cu
1552 - 1652 - 1702 - 1762	2 x 240/2 x 240	2 x 120/2 x 120	210/210	XLPE Cu	2 x 240/2 x 240	320/320	XLPE Cu
Units with option 81							
1002 to 1162	4 x 240	2 x 150	220	XLPE Cu	4 x 120	375	PVC Cu
1252 to 1762	4 x 240	4 x 120	210	XLPE Cu	4 x 240	400/400	PVC Cu
Units with options 81 and 150							
1002 to 1162	4 x 240	2 x 185	220	XLPE Cu	4 x 150	310	XLPE Cu
1252 to 1762	5 x 240	4 x 120	210	XLPE Cu	4 x 240	320	XLPE Cu

(1) Connection capacities actually available for each machine, defined according to the connection terminal size, the control box access opening size and the available space inside the control box.

(2) Selection simulation result considering the hypothesis indicated.

(3) If the maximum calculated section is for an XLPE cable type, this means that a selection based on a PVC cable type can exceed the connection capacity actually available. Special attention must be given to the selection.

Note: The currents considered are given for a machine equipped with a hydraulic module operating at maximum current.

5.5 - Power cable entry

The power cables can enter the 30XW control box from above the unit. A removable aluminium plate on the upper part of the control box face allows introduction of the cables. Refer to the certified dimensional drawing for the unit.

- Evaporator pump control
- Heat reclaim condenser pump control (option)
- Hot water valve control (option)
- Various interlocks on the Energy Management Module (EMM) board (accessory or option)

5.6 - Field control wiring

IMPORTANT: Field connection of interface circuits may lead to safety risks: any control box modification must maintain equipment conformity with local regulations. Precautions must be taken to prevent accidental electrical contact between circuits supplied by different sources:

- The routing selection and/or conductor insulation characteristics must ensure dual electric insulation.
- In case of accidental disconnection, conductor fixing between different conductors and/or in the control box prevents any contact between the conductor ends and an active energised part.

Refer to the SmartVu™ Control manual and the certified wiring diagram supplied with the unit for the field control wiring of the following features:

- Remote on/off switch
- Demand limit external switch
- Remote dual set point
- Alarm, alert and operation report

CCN bus connection

- The permanent connection to the system CCN bus is made at the terminal provided for this purpose inside the control box.
- The connection of the CCN service tool is possible at a socket under the control box, accessible from outside.

5.7 - 24 and 230 V power reserve for the user

Control circuit reserve:

After all required options have been connected, the TC transformer includes a power reserve that can be used for the field control wiring:

- Unit without option 084⁽¹⁾ 2 A (24 V a.c.) or 48 VA
 - Unit with option 084⁽¹⁾ 1.3 A (24 V a.c.) or 30 VA
- (1) 084 or 084R or 084D

As an option, a the 230 V, 50 Hz circuit allows the supply of a battery charger for a portable computer at 1 A maximum at 230 V. The connection is via a CEE7/7 type socket (2 poles with earth) located under the control box and accessible from outside.

6 - APPLICATION DATA

6.1 - Operating limits for 30XW units

30XW--/30XW-P	Minimum	Maximum
Evaporator		
Entering temperature at start-up	-	35,0°C
Leaving temperature during operation	3,3°C ⁽¹⁾	20,0°C
Entering/leaving temperature difference at full load	2,8 K	11,1 K
Condenser		
Entering temperature at start-up	13,0°C ⁽²⁾	-
Leaving temperature during operation	19,0°C ⁽²⁾	50,0°C ⁽³⁾
Entering/leaving temperature difference at full load	2,8 K	11,1 K

- (1) For low-temperature applications, where the leaving water temperature is below 3.3°C, a frost protection solution must be used. Please refer to option 6.
- (2) For lower condenser temperatures a water flow control valve must be used at the condenser (two or three-way valve). Please refer to option 152 to ensure the correct condensing temperature.
- (3) Please refer to option 150 for applications with a high condenser leaving temperature (up to 63°C).

Note: Ambient temperatures: These units are dedicated for indoor environment. The external temperature at chiller start up should be at least 5°C. For such low ambient, option 152 is recommended. During storage and transport of the 30XW units (including by container) the minimum and maximum permissible temperatures are -20°C and 72°C (and 65°C for option 200).

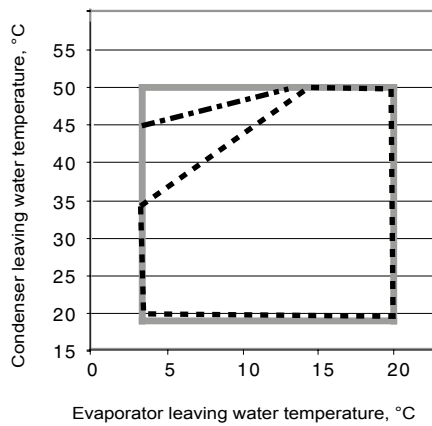

- From approx. 45% to full load
- - - Part load limit approx. 35%
- · · Minimum load limit approx. 15%

For more precise details refer to the unit selection program.

6.2 - Minimum chilled water flow

The minimum chilled water flow is shown in the table in chapter 6.6.

If the system flow is less than the minimum unit flow rate, the evaporator flow can be recirculated, as shown in the diagram.

6.5 - Standard and optional number of water passes

■ Standard-efficiency units 30XW--

Size	254	304	354	402	452	552	602	652	702	802	852	1002	1052	1154	1252	1352	1452	1552	1652	1702
Evaporator																				
Standard	2	2	2	2	2	2	2	2	2	2	2	2	2	2	2	2	2	2	2	2
Option 100C	1	1	1	1	1	1	1	1	1	1	1	1	1	1	1	1	1	1	1	1
Condenser																				
Standard	2	2	2	2	2	2	2	2	2	2	2	2	2	2	2	2	2	2	2	2
Option 102C	1	1	1	1	1	1	1	1	1	1	1	1	1	1	1	1	1	1	1	1

For minimum chilled water flow rate

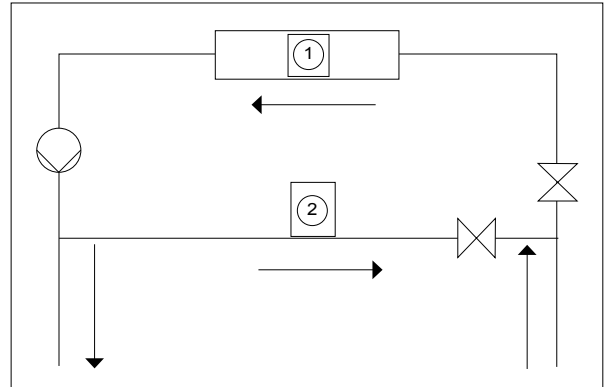

- Legend**
- 1. Evaporator
 - 2. Recirculation

6.3 - Maximum chilled water flow

The maximum chilled water flow is limited by the permitted pressure drop in the evaporator. It is provided in the table in chapter 6.6.

- Select the option with one water pass less that will allow a higher maximum water flow rate (see option 100C in the table in chapter 6.5).
- Bypass the evaporator as shown in the diagram to obtain a lower evaporator flow rate.

For maximum chilled water flow rate

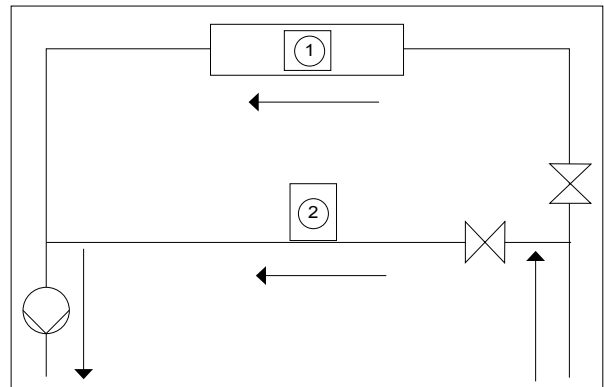

- Legend**
- 1. Evaporator
 - 2. Bypass

6.4 - Condenser water flow rate

The minimum and maximum condenser water flow rates are shown in the table in chapter 6.6.

If the system flow is higher than the maximum unit flow rate, select the option with one pass less that will allow a higher maximum water flow rate. Please refer to option 102C in the table in chapter 6.5.

6 - APPLICATION DATA

■ High-efficiency units 30XW-P

Size	512	562	712	812	862	1012	1162	1314	1464	1612	1762
Evaporator											
Standard	2	2	2	2	2	2	2	2	2	2	2
Option 100C	1	1	1	1	1	1	1	1	1	1	1
Condenser											
Standard	2	2	2	2	2	2	2	2	2	2	2
Option 102C	1	1	1	1	1	1	1	1	1	1	1

6.6 - Evaporator and condenser water flow rates

These below values are given for standard units. For options 100C and 102C, please refer to the unit selection program.

■ Standard-efficiency units 30XW--

Size	254	304	354	402	452	552	602	652	702	802	852	1002	1052	1154	1252	1352	1452	1552	1652	1702
Evaporator water flow rate, l/s																				
Minimum	6	6	6	7	7	7	7	9	9	9	9	13	13	15	18	18	18	18	22	22
Maximum	39	39	39	39	43	43	43	57	57	57	61	67	67	78	84	84	84	84	116	116
Condenser water flow rate, l/s																				
Minimum	4	4	4	4	4	4	4	6	6	6	8	8	8	9	12	12	12	12	14	14
Maximum	29	29	29	29	47	47	47	55	55	55	82	82	82	109	119	119	119	119	134	134

■ High-efficiency units 30XW-P

Size	512	562	712	812	862	1012	1162	1314	1464	1612	1762
Evaporator water flow rate, l/s											
Minimum	10	10	13	13	13	18	18	22	22	28	28
Maximum	57	57	76	76	76	84	84	116	116	121	121
Condenser water flow rate, l/s											
Minimum	6	6	8	8	8	12	12	18	18	22	22
Maximum	55	55	74	74	74	119	119	130	130	149	149

Notes

- Minimum evaporator flow rate based on a water velocity of 0,5 m/s.
- Minimum condenser flow rate based on a water velocity of 0,3 m/s.
- Maximum flow rate based on a pressure drop of 120 kPa (units with two evaporator passes and two condenser passes).

6.7 - Variable flow evaporator

Variable evaporator flow can be used. The controlled flow rate must be higher than the minimum flow given in the table of permissible flow rates and must not vary by more than 10% per minute.

If the flow rate changes more rapidly, the system should contain a minimum of 6.5 litres of water per kW instead of 3.25 l/kW.

It is possible to use a dedicated terminal to connect the pump drive (0/10V signal) .

Please refer to SmartVu™ control manual.

6.8 - System minimum water volume

Whichever the system, the water loop minimum volume is given by the formula: Volume = Cap (kW) x N litres

Application	N
Normal air conditioning	3,25
Process type cooling	6,5

Where Cap is the nominal system cooling capacity (kW) at the nominal operating conditions of the installation.

This volume is necessary for stable operation.

It is often necessary to add a buffer water tank to the circuit in order to achieve the required volume. The tank must itself be internally baffled in order to ensure proper mixing of the liquid (water or brine). Refer to the examples below.

Connection to a buffer tank

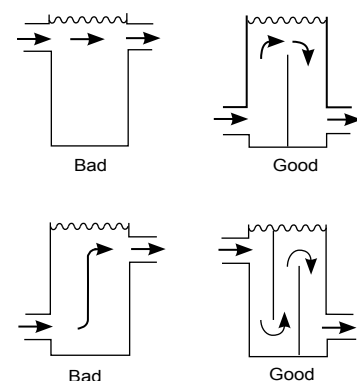

6 - APPLICATION DATA

6.9 - Evaporator pressure drop curves

**Units with two evaporator passes (standard):
30XW--/30XWH-/30XW-P/30XWHP**

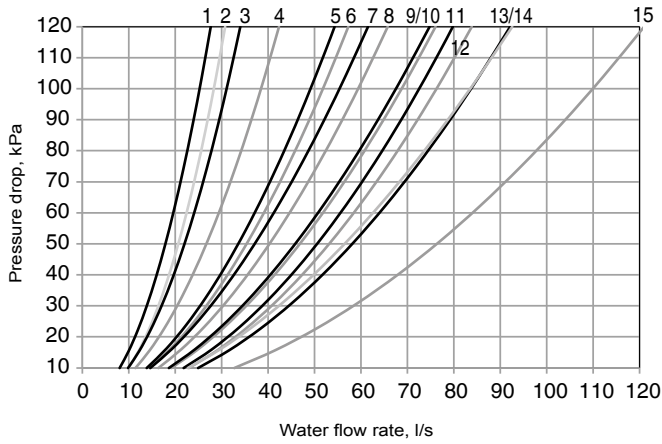

- Legend**
- | | |
|-----------------------|----------------------------|
| 1. 254 | 9. 1154 |
| 2. 304 | 10. 712, 812, 862 |
| 3. 354 | 11. 1012, 1162 |
| 4. 402, 452, 552, 602 | 12. 1252, 1352, 1452, 1552 |
| 5. 512, 562 | 13. 1314, 1464 |
| 6. 652, 702, 802 | 14. 1652, 1702 |
| 7. 852 | 15. 1612, 1762 |
| 8. 1002, 1052 | |

**Units with one evaporator pass (option 100C):
30XW--/30XWH-/30XW-P/30XWHP**

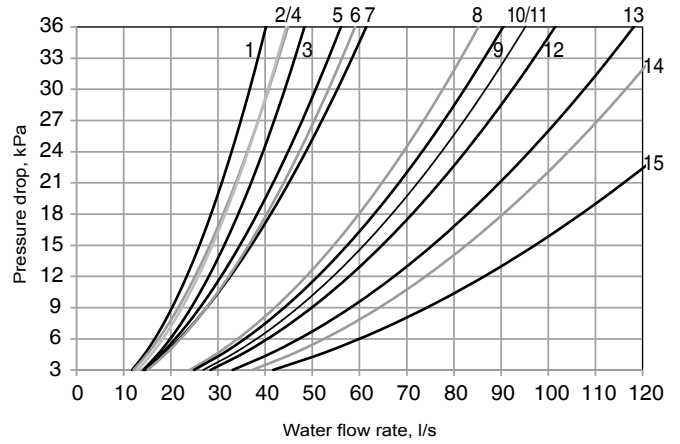

- Legend**
- | | |
|-----------------------|----------------------------|
| 1. 254 | 9. 1012, 1162 |
| 2. 304 | 10. 712, 812, 862 |
| 3. 354 | 11. 1252, 1352, 1452, 1552 |
| 4. 402, 452, 552, 602 | 12. 1154 |
| 5. 512, 562 | 13. 1314, 1464 |
| 6. 652, 702, 802 | 14. 1652, 1702 |
| 7. 852 | 15. 1612, 1762 |
| 8. 1002, 1052 | |

6.10 - Condenser pressure drop curves

**Units with two condenser passes (standard):
30XW--/30XWH-/30XW-P/30XWHP**

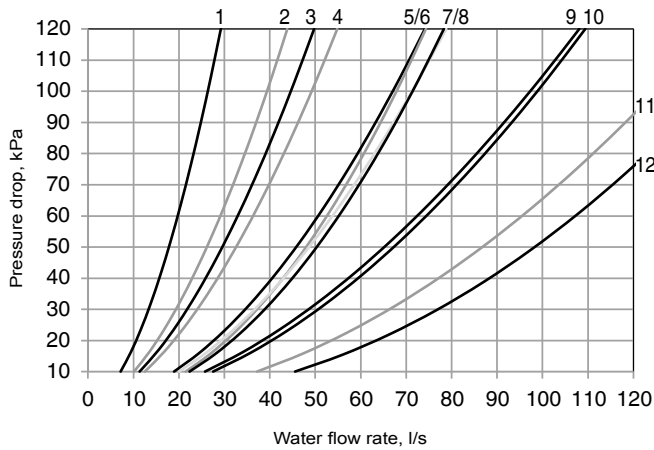

- Legend**
- | | |
|-----------------------|--|
| 1. 254, 304, 354 | 7. 1154 |
| 2. 402, 452, 552, 602 | 8. 1002, 1052 |
| 3. 512, 562 | 9. 1012, 1162 |
| 4. 652, 702, 802 | 10. 1252, 1352, 1452, 1552, 1314, 1464 |
| 5. 712, 812, 862 | 11. 1652, 1702 |
| 6. 852 | 12. 1612, 1762 |

**Units with one condenser pass (option 102C):
30XW--/30XWH-/30XW-P/30XWHP**

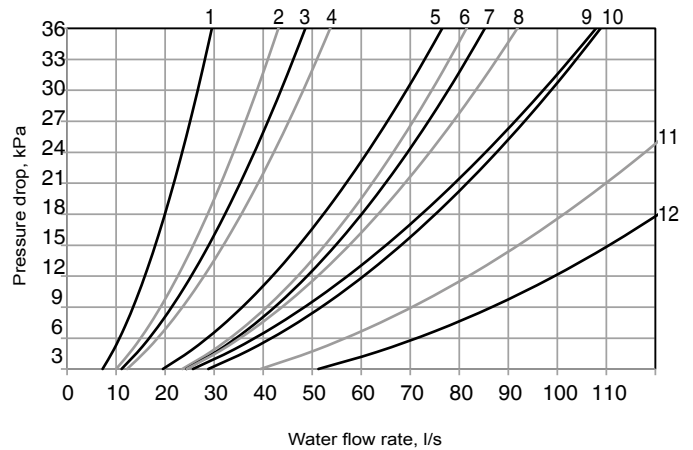

- Legend**
- | | |
|-----------------------|--|
| 1. 254, 304, 354 | 7. 1002, 1052 |
| 2. 402, 452, 552, 602 | 8. 1154 |
| 3. 512, 562 | 9. 1012, 1162 |
| 4. 652, 702, 802 | 10. 1252, 1352, 1452, 1552, 1314, 1464 |
| 5. 712, 812, 862 | 11. 1652, 1702 |
| 6. 852 | 12. 1612, 1762 |

7 - WATER CONNECTIONS

ATTENTION: Before carrying out any water connections install the water box purge plugs (one plug per water box in the lower section - supplied in the control box).

For size and position of the heat exchanger water inlet and outlet connections refer to the certified dimensional drawings supplied with the unit.

The water pipes must not transmit any radial or axial force to the heat exchangers nor any vibration.

The water supply must be analysed and appropriate filtering, treatment, control devices, isolation and bleed valves and circuits built in, to prevent corrosion, fouling and deterioration of the pump fittings. Consult either a water treatment specialist or appropriate literature on the subject.

7.1 - Operating precautions

The water circuit should be designed to have the least number of elbows and horizontal pipe runs at different levels. Below the main points to be checked for the connection:

- Comply with the water inlet and outlet connections shown on the unit.
- Install manual or automatic air purge valves at all high points in the circuit(s).
- Use a pressure reducer to maintain pressure in the circuit(s) and install a relief valve as well as an expansion tank.
- Install thermometers in both the entering and leaving water connections.
- Install drain connections at all low points to allow the whole circuit to be drained.
- Install stop valves, close to the entering and leaving water connections.
- Use flexible connections to reduce the transmission of vibrations.
- Insulate all pipework, after testing for leaks, both to reduce heat gains and to prevent condensation.
- Cover the insulation with a vapour barrier.
- Where there are particles in the fluid that could foul the heat exchanger, a screen filter should be installed ahead of the pump, or directly at the exchanger inlet in case the pump is more than 20m away. The mesh size of the filter must be 1.2 mm.
- Before the system start-up verify that the water circuits are connected to the appropriate heat exchangers (e.g. no reversal between evaporator and condenser).
- Do not introduce any significant static or dynamic pressure into the heat exchange circuit (with regard to the design operating pressures).
- Before any start-up verify that the heat exchange fluid is compatible with the materials and the water circuit coating.
- The use of different metals on hydraulic piping could generate electrolytic pairs and consequently corrosion. Verify then, the need to install sacrificial anodes.

In case additives or other fluids than those recommended by Carrier are used, ensure that the fluids are not considered as a gas, and that they belong to class 2, as defined in directive 2014/68/EU.

Carrier recommendations on heat exchange fluids:

- No NH_4^+ ammonium ions in the water, they are very detrimental for copper. This is one of the most important factors for the operating life of copper piping. A content of several tenths of mg/l will badly corrode the copper over time.
- Cl^- Chloride ions are detrimental for copper with a risk of perforations by corrosion by puncture. If possible keep below 125 mg/l.
- SO_4^{2-} sulphate ions can cause perforating corrosion, if their content is above 30 mg/l.
- No fluoride ions (<0.1 mg/l).
- No Fe^{2+} and Fe^{3+} ions with non negligible levels of dissolved oxygen must be present. Dissolved iron < 5 mg/l with dissolved oxygen < 5 mg/l.
- Dissolved silica: silica is an acid element of water and can also lead to corrosion risks. Content < 1 mg/l.
- Water hardness: > 0.5 mmol/l. Values between 1 and 2.5 can be recommended. This will facilitate scale deposit that can limit corrosion of copper. Values that are too high can cause piping blockage over time. A total alkalimetric titre (TAC) below 100 mg/l is desirable.
- Dissolved oxygen: Any sudden change in water oxygenation conditions must be avoided. It is as detrimental to deoxygenate the water by mixing it with inert gas as it is to over-oxygenate it by mixing it with pure oxygen. The disturbance of the oxygenation conditions encourages destabilisation of copper hydroxides and enlargement of particles.
- Electric conductivity 10-600 $\mu\text{S}/\text{cm}$.
- pH: Ideal case pH neutral at 20-25°C
7 < pH < 8

If the water circuit must be emptied for longer than one month, the complete circuit must be placed under nitrogen charge to avoid any risk of corrosion by differential aeration.

Charging and removing heat exchange fluids should be done with devices that must be included on the water circuit by the installer. Never use the unit heat exchangers to add heat exchange fluid.

7 - WATER CONNECTIONS

7.2 - Water connections

The water connections are Victaulic type connections. The inlet and outlet connection diameters are identical.

Inlet/outlet diameters

■ Standard-efficiency units 30XW-- / 30XWH-

Size		254	304	354	402	452	552	602	652	702	802
Evaporator											
Units without option 100C											
Nominal diameter	in	5	5	5	5	5	5	5	6	6	6
Actual outside diameter	mm	141,3	141,3	141,3	141,3	141,3	141,3	141,3	168,3	168,3	168,3
Option 100C											
Nominal diameter	in	5	5	5	6	6	6	6	6	6	6
Actual outside diameter	mm	141,3	141,3	141,3	168,3	168,3	168,3	168,3	168,3	168,3	168,3
Condenser											
Units without option 102C											
Nominal diameter	in	5	5	5	5	5	5	5	6	6	6
Actual outside diameter	mm	141,3	141,3	141,3	141,3	141,3	141,3	141,3	168,3	168,3	168,3
Option 102C											
Nominal diameter	in	6	6	6	6	6	6	6	8	8	8
Actual outside diameter	mm	168,3	168,3	168,3	168,3	168,3	168,3	168,3	219,1	219,1	219,1

Size		852	1002	1052	1154	1252	1352	1452	1552	1652	1702
Evaporator											
Units without option 100C											
Nominal diameter	in	6	6	6	8	8	8	8	8	8	8
Actual outside diameter	mm	168,3	168,3	168,3	219,1	219,1	219,1	219,1	219,1	219,1	219,1
Option 100C											
Nominal diameter	in	6	6	6	8	8	8	8	8	8	8
Actual outside diameter	mm	168,3	168,3	168,3	219,1	219,1	219,1	219,1	219,1	219,1	219,1
Condenser											
Units without option 102C											
Nominal diameter	in	8	8	8	8	8	8	8	8	8	8
Actual outside diameter	mm	219,1	219,1	219,1	219,1	219,1	219,1	219,1	219,1	219,1	219,1
Option 102C											
Nominal diameter	in	8	8	8	8	8	8	8	8	8	8
Actual outside diameter	mm	219,1	219,1	219,1	219,1	219,1	219,1	219,1	219,1	219,1	219,1

■ High-efficiency units 30XW-P / 30XWHP

Size		512	562	712	812	862	1012	1162	1314	1464	1612	1762
Evaporator												
Units without option 100C												
Nominal diameter	in	6	6	8	8	8	8	8	8	8	10	10
Actual outside diameter	mm	168,3	168,3	219,1	219,1	219,1	219,1	219,1	219,1	219,1	273,1	273,1
Option 100C												
Nominal diameter	in	6	6	8	8	8	8	8	8	8	10	10
Actual outside diameter	mm	168,3	168,3	219,1	219,1	219,1	219,1	219,1	219,1	219,1	273,1	273,1
Condenser												
Units without option 102C												
Nominal diameter	in	6	6	8	8	8	8	8	8	8	10	10
Actual outside diameter	mm	168,3	168,3	219,1	219,1	219,1	219,1	219,1	219,1	219,1	273,1	273,1
Option 102C												
Nominal diameter	in	8	8	8	8	8	8	8	8	8	10	10
Actual outside diameter	mm	219,1	219,1	219,1	219,1	219,1	219,1	219,1	219,1	219,1	273,1	273,1

7 - WATER CONNECTIONS

7.3 - Flow control

Evaporator flow switch and chilled water pump interlock

IMPORTANT: On 30XW units, the unit water flow switch must be energised. Failure to follow this instruction will void the Carrier guarantee.

The water flow switch is installed on the evaporator water inlet and adjusted by the control, based on unit size and application. If adjustment is necessary, it must be carried out by qualified personnel trained by Carrier Service.

7.4 - Evaporator and condenser water box bolt tightening

The evaporator (and condenser) are of the shell and tube type with removable water boxes to facilitate cleaning. Re-tightening or tightening must be done in accordance with the illustration in the example below.

Water box tightening sequence

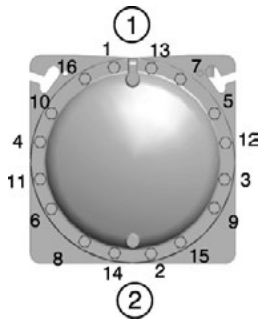

Legend

- | | | | |
|---|-------------------------|---|------------------------------|
| 1 | Sequence 1: 1 2 3 4 | 2 | Tightening torque |
| | Sequence 2: 5 6 7 8 | | Bolt size M16 - 171 - 210 Nm |
| | Sequence 3: 9 10 11 12 | | |
| | Sequence 4: 13 14 15 16 | | |

NOTE: Before this operation we recommend draining the circuit and disconnecting the pipes to be sure that the bolts are correctly and uniformly tightened.

7.5 - Operation of two units in master/slave mode

The control of a master/slave assembly is in the entering water and does not require any additional sensors (standard configuration). It can also be located in the leaving water. In this case two additional sensors must be added on the common piping.

All parameters, required for the master/slave function must be configured using the MST_SLV menu.

All remote controls of the master/slave assembly (start/stop, set point, load shedding etc.) are controlled by the unit configured as master and must only be applied to the master unit.

Each unit controls its own water pump. If there is only one common pump, in cases with variable flow, isolation valves must be installed on each unit. They will be activated at the opening and closing by the control of each unit (in this case the valves are controlled using the dedicated water pump outputs). See the SmartVu™ Control IOM for a more detailed explanation.

30XW with configuration: leaving water control

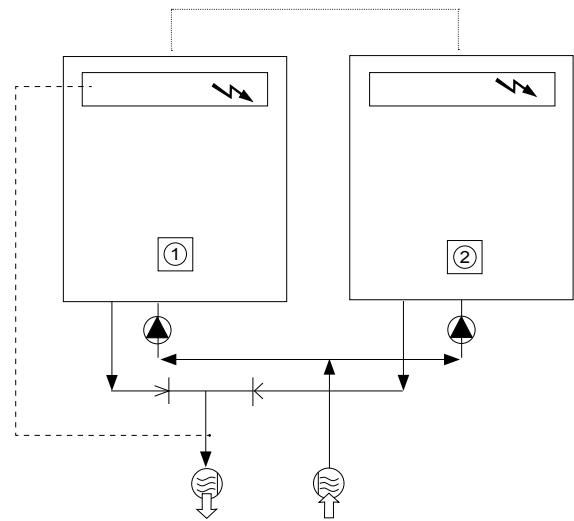

Legend

- ① Master unit
- ② Slave unit
- ⚡ Control boxes of the master and slave units
- 🌊➡ Water inlet
- 🌊➡ Water outlet
- ⚙️ Water pumps for each unit (included as standard for units with hydraulic module)
- Additional sensors for leaving water control, to be connected to channel 1 of the slave boards of each master and slave unit
- ... CCN communication bus
- Connection of two additional sensors

8 - HEAT MACHINE UNITS 30XWH- AND 30XWHP

8.1 - Physical data for Heat Machine units

The physical data for the Heat Machine units 30XWH-/ 30XWHP are the same as for the 30XW--/30XW-P units. Please refer to chapter 4.1.

8.2 - Electrical data for Heat Machine units

The electrical data for the Heat Machine units 30XWH-/ 30XWHP are the same as for the 30XW--/30XW-P units. Please refer to chapter 4.2.

8.3 - Dimensions and clearances for Heat Machine units

The dimensions and clearances are the same as for the 30XW--/30XW-P units. Please refer to chapter 3.

8.4 - Operating range for Heat Machine units

The operating limits are the same as for the 30XW--/30XW-P units. Please refer to chapter 6.1.

8.5 - Operating modes for Heat Machine units

8.5.1 - Cooling mode

This operating mode is the same as that for 30XW units. The unit controls on the cooling setpoint.

8.5.2 - Heating mode

Unlike in the cooling mode, the unit uses the heating setpoint in this configuration. The evaporator leaving water control (lowest setpoint taken into consideration) is still maintained to prevent operation at very low temperatures.

9 - OPTION FOR HIGH CONDENSING TEMPERATURE (OPTION 150)

9.1 - Physical data, units with option 150

■ Standard-efficiency units (option 150)

30XW--/30XWH		254	304	354	402	452	552	602	652	702	802
Sound levels - unit with option 150											
Sound power level ⁽¹⁾	dB(A)	95	95	95	99	99	99	99	102	102	102
Sound pressure level at 1 m ⁽²⁾	dB(A)	78	78	78	82	82	82	82	84	84	84
Sound levels - unit with option 150 + option 257⁽³⁾											
Sound power level ⁽¹⁾	dB(A)	-	-	-	96	96	96	96	100	100	100
Sound pressure level at 1 m ⁽²⁾	dB(A)	-	-	-	78	78	78	78	82	82	82
Dimensions - unit with option 150											
Length	mm	2724	2724	2724	2741	2741	2741	2741	3059	3059	3059
Width	mm	928	928	928	936	936	936	936	1090	1090	1090
Height	mm	1567	1567	1567	1692	1692	1692	1692	1858	1858	1858
Operating weight⁽⁴⁾	kg	2017	2036	2072	2575	2575	2613	2644	3407	3438	3462
Compressors											
Semi-hermetic 06T screw compressors, 50 r/s											
Circuit A		1	1	1	1	1	1	1	1	1	1
Circuit B		-	-	-	-	-	-	-	-	-	-
Refrigerant⁽⁴⁾											
R-134a											
Circuit A	kg	84	80	78	92	92	92	92	145	135	125
	teqCO ₂	120	114	112	132	132	132	132	207	193	179
Circuit B	kg	-	-	-	-	-	-	-	-	-	-
	teqCO ₂	-	-	-	-	-	-	-	-	-	-
Oil - unit with option 150											
Circuit A	l	23,5	23,5	23,5	32	32	32	32	36	36	36
Circuit B	l	-	-	-	-	-	-	-	-	-	-
Capacity control											
SmartVu™, electronic expansion valves (EXV)											
Minimum capacity ⁽⁵⁾	%	15	15	30	30	30	30	30	15	15	30
Evaporator											
Multi-pipe flooded type											
Net water volume	l	50	56	61	70	70	70	70	109	109	109
Water connections (Victaulic)	in	5	5	5	5	5	5	5	6	6	6
Drain and vent connections (NPT)	in	3/8	3/8	3/8	3/8	3/8	3/8	3/8	3/8	3/8	3/8
Max. water-side operating pressure	kPa	1000	1000	1000	1000	1000	1000	1000	1000	1000	1000
Condenser											
Multi-pipe flooded type											
Net water volume	l	55	55	55	76	76	76	76	109	109	109
Water connections (Victaulic)	in	5	5	5	5	5	5	5	6	6	6
Drain and vent connections (NPT)	in	3/8	3/8	3/8	3/8	3/8	3/8	3/8	3/8	3/8	3/8
Max. water-side operating pressure	kPa	1000	1000	1000	1000	1000	1000	1000	1000	1000	1000

(1) In dB ref=10⁻¹² W, (A) weighting. Declared dualnumber noise emission values in accordance with ISO 4871 (with an associated uncertainty of +/-3dB(A)). Measured in accordance with ISO 9614-1 and certified by Eurovent.

(2) In dB ref 20μPa, (A) weighting. Declared dualnumber noise emission values in accordance with ISO 4871 (with an associated uncertainty of +/-3dB(A)). For information, calculated from the sound power level Lw(A).

(3) Option 257 = Low noise level

(4) Weight shown is guideline only. Please refer to the unit nameplate.

(5) Minimum unit capacity corresponds to a physical state of the unit and is given for indication only. The actual capacity at this stage depends on operating conditions.



Eurovent certified values

9 - OPTION FOR HIGH CONDENSING TEMPERATURE (OPTION 150)

■ Standard-efficiency units (option 150)

30XW--/30XWH		852	1002	1052	1154	1252	1352	1452	1552	1652	1702
Sound levels - unit with option 150											
Sound power level ⁽¹⁾	dB(A)	102	102	102	102	105	105	105	105	105	105
Sound pressure level at 1 m ⁽²⁾	dB(A)	84	84	84	84	86	86	86	86	86	86
Sound levels - unit with option 150 + option 257⁽³⁾											
Sound power level ⁽¹⁾	dB(A)	100	99	99	99	103	103	103	103	103	103
Sound pressure level at 1 m ⁽²⁾	dB(A)	82	80	80	80	84	84	84	84	84	84
Dimensions - unit with option 150											
Length	mm	2780	4025	4025	4025	4730	4730	4730	4730	4790	4790
Width	mm	1090	1036	1036	1036	1201	1201	1201	1201	1947	1947
Height	mm	1920	1870	1870	1925	2071	2071	2071	2071	1535	1535
Operating weight ⁽⁴⁾	kg	3672	5370	5408	5698	7233	7554	7622	7670	9006	9032
Compressors											
Semi-hermetic 06T screw compressors, 50 r/s											
Circuit A		1	1	1	1	1	1	1	1	1	1
Circuit B		-	1	1	1	1	1	1	1	1	1
Refrigerant⁽⁴⁾											
R-134a											
Circuit A	kg	158	85	85	105	120	115	110	105	195	195
	teqCO ₂	226	122	122	150	172	164	157	150	279	279
Circuit B	kg	-	85	85	105	120	115	110	105	195	195
	teqCO ₂	-	122	122	150	172	164	157	150	279	279
Oil - unit with option 150											
Circuit A	l	36	32	32	32	36	36	36	36	36	36
Circuit B	l	-	32	32	32	32	36	36	36	36	36
Capacity control											
SmartVu™, electronic expansion valves (EXV)											
Minimum capacity ⁽⁵⁾	%	30	30	30	30	15	15	15	30	30	30
Evaporator											
Multi-pipe flooded type											
Net water volume	l	98	182	182	205	301	301	301	301	354	354
Water connections (Victaulic)	in	6	6	6	8	8	8	8	8	8	8
Drain and vent connections (NPT)	in	3/8	3/8	3/8	3/8	3/8	3/8	3/8	3/8	3/8	3/8
Max. water-side operating pressure	kPa	1000	1000	1000	1000	1000	1000	1000	1000	1000	1000
Condenser											
Multi-pipe flooded type											
Net water volume	l	137	193	193	193	340	340	340	340	426	426
Water connections (Victaulic)	in	8	8	8	8	8	8	8	8	8	8
Drain and vent connections (NPT)	in	3/8	3/8	3/8	3/8	3/8	3/8	3/8	3/8	3/8	3/8
Max. water-side operating pressure	kPa	1000	1000	1000	1000	1000	1000	1000	1000	1000	1000

(1) In dB ref=10⁻¹² W, (A) weighting. Declared dualnumber noise emission values in accordance with ISO 4871 (with an associated uncertainty of +/-3dB(A)). Measured in accordance with ISO 9614-1 and certified by Eurovent.

(2) In dB ref 20µPa, (A) weighting. Declared dualnumber noise emission values in accordance with ISO 4871 (with an associated uncertainty of +/-3dB(A)). For information, calculated from the sound power level Lw(A).

(3) Option 257 = Low noise level

(4) Weight shown is guideline only. Please refer to the unit nameplate.

(5) Minimum unit capacity corresponds to a physical state of the unit and is given for indication only. The actual capacity at this stage depends on operating conditions.



Eurovent certified values

9 - OPTION FOR HIGH CONDENSING TEMPERATURE (OPTION 150)

■ High-efficiency units (option 150)

30XW-P/30XWHP		512	562	712	812	862	1012	1162	1314	1464	1612	1762
Sound levels - unit with option 150												
Sound power level ⁽¹⁾	dB(A)	99	99	102	102	102	102	102	105	105	105	105
Sound pressure level at 1 m ⁽²⁾	dB(A)	82	82	84	84	84	83	83	86	86	86	86
Sound levels - unit with option 150 + option 257⁽³⁾												
Sound power level ⁽¹⁾	dB(A)	96	96	100	100	100	99	99	103	103	103	103
Sound pressure level at 1 m ⁽²⁾	dB(A)	78	78	82	82	82	80	80	84	84	84	84
Dimensions - unit with option 150												
Length	mm	3059	3059	3290	3290	3290	4730	4730	4730	4730	4832	4832
Width	mm	936	936	1105	1105	1105	1039	1039	1202	1202	2174	2174
Height	mm	1743	1743	1970	1970	1970	1997	1997	2071	2071	1585	1585
Operating weight ⁽⁴⁾	kg	2981	3020	4072	4117	4145	6872	6950	7721	8059	11225	11279
Compressors												
Semi-hermetic 06T screw compressors, 50 r/s												
Circuit A		1	1	1	1	1	1	1	1	1	1	1
Circuit B		-	-	-	-	-	1	1	1	1	1	1
Refrigerant⁽⁴⁾ - unit with option 150												
R-134a												
Circuit A	kg	130	130	180	175	170	120	120	130	130	240	250
	teqCO ₂	186	186	257	250	243	172	172	186	186	343	358
Circuit B	kg	-	-	-	-	-	120	120	150	130	240	250
	teqCO ₂	-	-	-	-	-	172	172	215	186	343	358
Oil - unit with option 150												
Circuit A	l	32	32	36	36	36	32	32	36	36	36	36
Circuit B	l	-	-	-	-	-	32	32	32	36	36	36
Capacity control												
SmartVu™, electronic expansion valves (EXV)												
Minimum capacity ⁽⁵⁾	%	30	30	15	15	30	30	30	15	15	15	30
Evaporator												
Multi-pipe flooded type												
Net water volume	l	101	101	154	154	154	293	293	321	321	473	473
Water connections (Victaulic)	in	6	6	8	8	8	8	8	8	8	10	10
Drain and vent connections (NPT)	in	3/8	3/8	3/8	3/8	3/8	3/8	3/8	3/8	3/8	3/8	3/8
Max. water-side operating pressure	kPa	1000	1000	1000	1000	1000	1000	1000	1000	1000	1000	1000
Condenser												
Multi-pipe flooded type												
Net water volume	l	103	103	148	148	148	316	316	340	340	623	623
Water connections (Victaulic)	in	6	6	8	8	8	8	8	10	10	10	10
Drain and vent connections (NPT)	in	3/8	3/8	3/8	3/8	3/8	3/8	3/8	3/8	3/8	3/8	3/8
Max. water-side operating pressure	kPa	1000	1000	1000	1000	1000	1000	1000	1000	1000	1000	1000

(1) In dB ref=10⁻¹² W, (A) weighting. Declared dualnumber noise emission values in accordance with ISO 4871 (with an associated uncertainty of +/-3dB(A)). Measured in accordance with ISO 9614-1 and certified by Eurovent.

(2) In dB ref 20μPa, (A) weighting. Declared dualnumber noise emission values in accordance with ISO 4871 (with an associated uncertainty of +/-3dB(A)). For information, calculated from the sound power level Lw(A).

(3) Option 257 = Low noise level

(4) Weight shown is guideline only. Please refer to the unit nameplate.

(5) Minimum unit capacity corresponds to a physical state of the unit and is given for indication only. The actual capacity at this stage depends on operating conditions.



Eurovent certified values

9 - OPTION FOR HIGH CONDENSING TEMPERATURE (OPTION 150)

9.2 - Electrical data, units with option 150

■ Standard-efficiency units (option 150)

30XW--/30XWH		254	304	354	402	452	552	602	652	702	802
Power circuit											
Nominal power supply	V-ph-Hz	400-3-50									
Voltage range	V	360-440									
Control circuit											
24 V via the built-in transformer											
Nominal start-up current⁽¹⁾											
Circuit A	A	303	388	388	587	587	587	587	772	772	772
Circuit B	A	-	-	-	-	-	-	-	-	-	-
Option 81	A	-	-	-	-	-	-	-	-	-	-
Maximum start-up current⁽²⁾											
Circuit A	A	303	388	388	587	587	587	587	772	772	772
Circuit B	A	-	-	-	-	-	-	-	-	-	-
Option 81	A	-	-	-	-	-	-	-	-	-	-
Cosine phi nominal⁽³⁾											
		0,79	0,78	0,79	0,83	0,85	0,85	0,85	0,84	0,86	0,87
Cosine phi maximum⁽⁴⁾											
		0,88	0,87	0,88	0,90	0,90	0,91	0,91	0,90	0,90	0,90
Total harmonic distortion⁽⁴⁾											
	%	0	0	0	0	0	0	0	0	0	0
Maximum power input*											
Circuit A	kW	97	111	122	156	173	191	191	249	268	286
Circuit B	kW	-	-	-	-	-	-	-	-	-	-
Option 81	kW	-	-	-	-	-	-	-	-	-	-
Nominal current drawn⁽³⁾											
Circuit A	A	95	109	125	150	162	171	171	193	214	232
Circuit B	A	-	-	-	-	-	-	-	-	-	-
Option 81	A	-	-	-	-	-	-	-	-	-	-
Maximum current drawn (Un)*											
Circuit A	A	160	185	200	250	275	300	300	400	430	460
Circuit B	A	-	-	-	-	-	-	-	-	-	-
Option 81	A	-	-	-	-	-	-	-	-	-	-
Max. current drawn (Un -10%)⁽⁴⁾											
Circuit A	A	176	206	224	270	300	330	330	419	455	476
Circuit B	A	-	-	-	-	-	-	-	-	-	-
Option 81	A	-	-	-	-	-	-	-	-	-	-

- (1) Instantaneous start-up current (maximum operating current of the smallest compressor(s) + locked rotor current or reduced start-up current of the largest compressor).
Values based on standard Eurovent unit operating conditions: evaporator entering/leaving water temp. = 12°C/7°C, condenser entering/leaving water temp. = 30°C/35°C.
- (2) Instantaneous start-up current (maximum operating current of the smallest compressor(s) + locked rotor current or reduced start-up current of the largest compressor).
Values obtained at operation with maximum unit power input.
- (3) Values based on standard Eurovent unit operating conditions: evaporator entering/leaving water temp. = 12°C/7°C, condenser entering/leaving water temp. = 30°C/35°C.
- (4) Values obtained at operation with maximum unit power input.
- * Values obtained at operation with maximum unit power input. Values given on the unit name plate.

9 - OPTION FOR HIGH CONDENSING TEMPERATURE (OPTION 150)

■ Standard-efficiency units (option 150)

30XW--/30XWH		852	1002	1052	1154	1252	1352	1452	1552	1652	1702
Power circuit											
Nominal power supply	V-ph-Hz	400-3-50									
Voltage range	V	360-440									
Control circuit											
24 V via the built-in transformer											
Nominal start-up current⁽¹⁾											
Circuit A	A	772	587	587	587	772	772	772	772	772	772
Circuit B	A	-	587	587	587	587	772	772	772	772	772
Option 81	A	-	757	757	757	943	965	986	1004	1004	1004
Maximum start-up current⁽²⁾											
Circuit A	A	772	587	587	587	772	772	772	772	772	772
Circuit B	A	-	587	587	587	587	772	772	772	772	772
Option 81	A	-	887	887	887	1072	1172	1202	1232	1004	1232
Cosine phi nominal⁽³⁾											
0,87 0,85 0,85 0,85 0,86 0,85 0,86 0,87 0,86 0,87											
Cosine phi maximum⁽⁴⁾											
0,90 0,90 0,91 0,91 0,91 0,91 0,91 0,91 0,91 0,91											
Total harmonic distortion⁽⁴⁾											
% 0 0 0 0 0 0 0 0 0 0 0											
Maximum power input*											
Circuit A	kW	286	191	191	191	252	252	271	290	290	290
Circuit B	kW	-	173	191	191	191	252	271	290	271	290
Option 81	kW	-	364	382	382	443	504	542	580	562	580
Nominal current drawn⁽³⁾											
Circuit A	A	232	171	171	171	210	210	230	250	250	250
Circuit B	A	-	162	171	171	171	210	230	250	230	250
Option 81	A	-	333	342	342	381	420	460	500	480	500
Maximum current drawn (Un)*											
Circuit A	A	460	300	300	300	400	400	430	460	460	460
Circuit B	A	-	275	300	300	300	400	430	460	430	460
Option 81	A	-	575	600	600	700	800	860	920	890	920
Max. current drawn (Un -10%)⁽⁴⁾											
Circuit A	A	476	330	330	330	419	419	455	476	476	476
Circuit B	A	-	300	330	330	330	419	455	476	455	476
Option 81	A	-	630	660	660	749	838	910	952	931	952

(1) Instantaneous start-up current (maximum operating current of the smallest compressor(s) + locked rotor current or reduced start-up current of the largest compressor). Values based on standard Eurovent unit operating conditions: evaporator entering/leaving water temp. = 12°C/7°C, condenser entering/leaving water temp. = 30°C/35°C.

(2) Instantaneous start-up current (maximum operating current of the smallest compressor(s) + locked rotor current or reduced start-up current of the largest compressor). Values obtained at operation with maximum unit power input.

(3) Values based on standard Eurovent unit operating conditions: evaporator entering/leaving water temp. = 12°C/7°C, condenser entering/leaving water temp. = 30°C/35°C.

(4) Values obtained at operation with maximum unit power input.

* Values obtained at operation with maximum unit power input. Values given on the unit name plate.

9 - OPTION FOR HIGH CONDENSING TEMPERATURE (OPTION 150)

■ High-efficiency heat units (option 150)

30XW-P/30XWHP		512	562	712	812	862	1012	1162	1314	1464	1612	1762
Power circuit												
Nominal power supply	V-ph-Hz	400-3-50										
Voltage range	V	360-440										
Control circuit												
24 V via the built-in transformer												
Nominal start-up current⁽¹⁾												
Circuit A	A	587	587	772	772	772	587	587	772	772	772	772
Circuit B	A	-	-	-	-	-	587	587	587	772	772	772
Option 81	A	-	-	-	-	-	749	757	943	965	986	1004
Maximum start-up current⁽²⁾												
Circuit A	A	587	587	772	772	772	587	587	772	772	772	772
Circuit B	A	-	-	-	-	-	587	587	587	772	772	772
Option 81	A	-	-	-	-	-	862	887	1072	1172	1202	1232
Cosine phi nominal⁽³⁾												
0,88 0,88 0,84 0,86 0,87 0,87 0,88 0,86 0,85 0,86 0,87												
Cosine phi maximum⁽⁴⁾												
0,91 0,92 0,90 0,90 0,90 0,91 0,92 0,91 0,91 0,91 0,91												
Total harmonic distortion⁽⁴⁾												
% 0 0 0 0 0 0 0 0 0 0 0 0												
Maximum power input*												
Circuit A	kW	173	191	252	271	290	173	191	252	252	271	290
Circuit B	kW	-	-	-	-	-	173	191	191	252	271	290
Option 81	kW	-	-	-	-	-	346	382	443	504	542	580
Nominal current drawn⁽³⁾												
Circuit A	A	162	171	210	230	250	162	171	210	210	230	250
Circuit B	A	-	-	-	-	-	162	171	171	210	230	250
Option 81	A	-	-	-	-	-	324	342	381	420	460	500
Maximum current drawn (Un)*												
Circuit A	A	275	300	400	430	460	275	300	400	400	430	460
Circuit B	A	-	-	-	-	-	275	300	300	400	430	460
Option 81	A	-	-	-	-	-	550	600	700	800	860	920
Maximum current drawn (Un -10%)⁽⁴⁾												
Circuit A	A	300	330	419	455	476	300	330	419	419	455	476
Circuit B	A	-	-	-	-	-	300	330	330	419	455	476
Option 81	A	-	-	-	-	-	600	660	749	838	910	952

- (1) Instantaneous start-up current (maximum operating current of the smallest compressor(s) + locked rotor current or reduced start-up current of the largest compressor). Values based on standard Eurovent unit operating conditions: evaporator entering/leaving water temp. = 12°C/7°C, condenser entering/leaving water temp. = 30°C/35°C.
- (2) Instantaneous start-up current (maximum operating current of the smallest compressor(s) + locked rotor current or reduced start-up current of the largest compressor). Values obtained at operation with maximum unit power input.
- (3) Values based on standard Eurovent unit operating conditions: evaporator entering/leaving water temp. = 12°C/7°C, condenser entering/leaving water temp. = 30°C/35°C.
- (4) Values obtained at operation with maximum unit power input.
- * Values obtained at operation with maximum unit power input. Values given on the unit name plate.

9.3 - Dimensions and clearances, units with option 150

Please refer to chapter 3.

9.4 - Operating limits, units with option 150

30XW--/30XWH-/30XW-P/30XWHP	Maximum	Minimum
Evaporator		
Entering temperature at start-up	35,0°C	-
Leaving temperature during operation	15,0°C	3,3°C ⁽¹⁾
Entering/leaving temperature difference at full load	11,1 K	2,8 K
Condenser		
Entering temperature at start-up	-	13,0°C ⁽²⁾
Leaving temperature during operation	63,0°C	23,0°C ⁽²⁾
Entering/leaving temperature difference at full load	11,1 K	2,8 K

- (1) For low-temperature applications, where the leaving water temperature is below 3,3°C, a frost protection solution must be used. Please refer to option 6.
- (2) For lower condenser temperatures a water flow control valve must be used at the condenser (two or three-way valve). Please refer to option 152 to ensure the correct condensing temperature.

Note: Ambient temperatures: During storage and transport of the 30XW units (including by container) the minimum and maximum permissible temperatures are -20°C and 72°C (and 65°C for option 200).

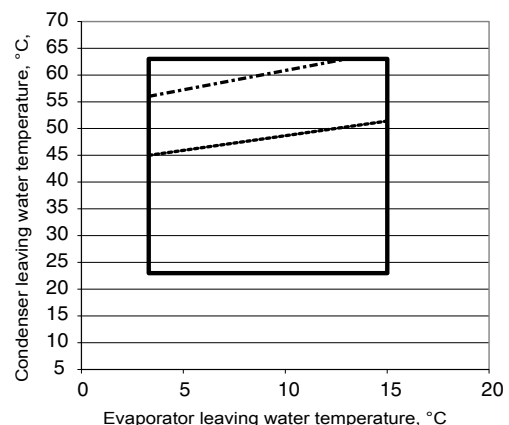

- From approx. 60% to full load
 - - - Part load limit approx. 50%
 . . . Minimum load limit approx. 30%

For more precise details refer to the unit selection program.

10 - OPTION 8 AND 6 FOR LIGHT AND LOW BRINE TEMPERATURE WITH ETHYLENE AND PROPYLENE GLYCOL

Option 8 enables chilled water production down to a temperature of -3°C with ethylene glycol and 0°C with propylene glycol. The unit is equipped with insulation on the low pressure pipes and new control algorithms.

Option 6 enables chilled water production down to a temperature of -15 °C with ethylene glycol and -10 °C with propylene glycol.

The unit is equipped with insulation on the low pressure pipes and on the compressor and new control algorithms and a single pass evaporator. Turbulators are installed in the evaporator pipes to maintain a good heat exchange down to a water outlet temperature of -15 °C.

The operating range is based on:

- the size of the machine,
- the type of glycol,
- its concentration,
- the flow rate,
- the temperature of the glycol solution,
- the condensing pressure (water temperature at condenser side).

Refer to the e-catalogue to find out the operating range for each unit.

Frost protection:

The protection provided to the evaporator against low pressure and freezing depend on the amount of antifreeze in the water loop. The evaporator pinch point ((water outlet temperature) - (evaporation temperature)) and the protection against ice formation, depend on the amount.

It is therefore crucial to check the amount of antifreeze in the loop carefully during the initial system start-up (allow it to circulate for 30 minutes to check that the mixture is homogeneous before sampling).

Refer to the manufacturer's data to define the frost protection, based on the measured concentration amount. The minimum temperature for frost protection must be entered in the parameters on the unit's controller.

This value will enable the following limits to be defined:

1. Evaporator antifreeze protection.
2. Low pressure protection.

For information, based on the antifreeze solutions used in our laboratories, the protection values provided by our supplier are as follows (these values may change depending on the supplier):

It is therefore recommended that system start-up for a low or very low temperature installation is performed by the manufacturer."

Freezing curve for Ethylene and Propylene glycol

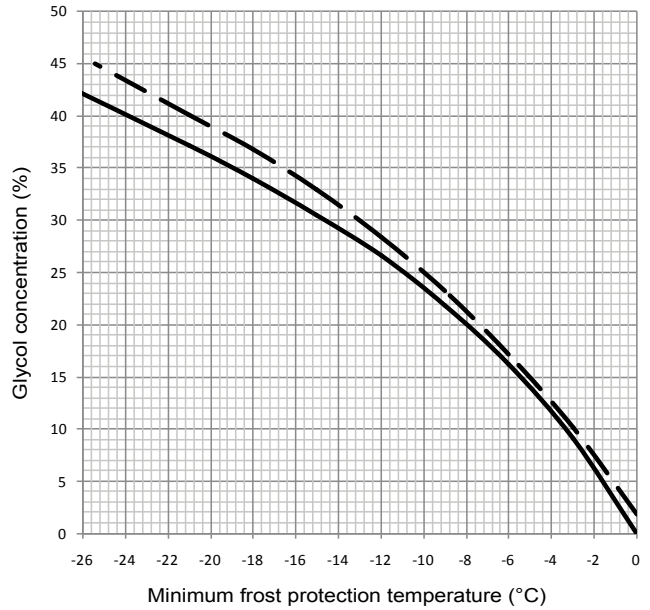

- Ethylene glycol (%)
- - Propylene glycol (%)

IMPORTANT:

- **It is vital to perform a (minimum) annual inspection of the glycol level and adjust the software's frost protection based on the measured level.**
- **This procedure must be performed systematically if water or antifreeze solution is added.**
- **Observe the minimum frost protection temperature based on the water outlet temperature.**

NOTE:

- **In the case of frost protection of the unit by low air temperature, the percentage brine must be evaluated accordingly.**
- **The maximum recommended temperature differential is 5 K.**
- **To facilitate maintenance operations, it is recommended that isolation valves are installed upstream and downstream of the machine**

It is essential to use precisely the correct concentration of glycol in the loop. Too high a concentration may have significant adverse effects on the performance of the evaporator, and therefore of the unit as a whole (decrease in the evaporation temperature). Too low a concentration may generate alarms or allow the evaporator to freeze. Damage caused by frost is not covered by the warranty.

Evaporator minimal brine flow :

Minimal flow is the same as for standard unit (see chapter "application data"). For variable flow, it is recommended to control pump on the Delta_T given on the Ecat full load selection.

IMPORTANT: Option 6 - Turbulators - water flow direction:

The water flow direction must be observed with the turbulators. If there is a risk that the flow will be reversed, check valves must be installed to guarantee the positioning of the turbulators."

10 - OPTION 8 AND 6 FOR LIGHT AND LOW BRINE TEMPERATURE WITH ETHYLENE AND PROPYLENE GLYCOL

10.1 - Physical data, unit with option 6

Standard-efficiency 30XW- / 30XWH units (options 6) ⁽¹⁾

Option 6 (very low temperature)

30XW--/30XWH (reference)		254	304	354	402	452	552	602	702	802
Operating weight	kg	2041	2063	2102	2609	2609	2647	2678	3492	3516
Compressors		Semi-hermetic 06T screw compressors, 50 r/s								
Circuit A		1	1	1	1	1	1	1	1	1
Circuit B		-	-	-	-	-	-	-	-	-
Refrigerant charge ⁽²⁾		R-134a								
Circuit A	kg	91	86	84	99	99	99	99	146	135
Circuit B	kg	0	0	0	0	0	0	0	0	0
Evaporator		Single pass, multi-pipe flooded type								
Water volume	l	50	56	61	70	70	70	70	109	109
Water connections (Victaulic)	in	5	5	5	6	6	6	6	6	6
Drain and vent connections (NPT)	in	3/8	3/8	3/8	3/8	3/8	3/8	3/8	3/8	3/8
Max. water-side operating pressure	kPa	1000	1000	1000	1000	1000	1000	1000	1000	1000

30XW--/30XWH (reference)		852	1002	1052	1154	1252	1452	1552	1652	1702
Operating weight	kg	3720	5467	5505	5806	7392	7781	7829	9193	9219
Compressors		Semi-hermetic 06T screw compressors, 50 r/s								
Circuit A		1	1	1	1	1	1	1	1	1
Circuit B		-	1	1	1	1	1	1	1	1
Refrigerant charge ⁽²⁾		R-134a								
Circuit A	kg	171	92	92	113	130	119	113	211	211
Circuit B	kg	0	92	92	113	130	119	113	211	211
Evaporator		Single pass, multi-pipe flooded type								
Water volume	l	98	182	182	205	301	301	301	354	354
Water connections (Victaulic)	in	6	6	6	8	8	8	8	8	8
Drain and vent connections (NPT)	in	3/8	3/8	3/8	3/8	3/8	3/8	3/8	3/8	3/8
Max. water-side operating pressure	kPa	1000	1000	1000	1000	1000	1000	1000	1000	1000

(1) Option 8 has same physical data as standard units

(2) Weights are guidelines only. The refrigerant charge is given on the unit nameplate.

10.2 - Operating range, units with 6 and 8

	Minimum	Maximum
Evaporator		
Entering water temperature at start-up °C	-	35
Leaving temperature during operation ⁽¹⁾		
EG 8 Option 8 with ethylene glycol °C	-3	15
PG 8 Option 8 with propylene glycol °C	0	15
EG 6 Option 6 with ethylene glycol °C	-15	15
PG 6 Option 6 with propylene glycol °C	-10	15
Entering/leaving temperature difference at full load ⁽³⁾	-	-
Condenser		
Entering water temperature at start-up °C	13 ⁽²⁾	-
Leaving temperature during operation ⁽²⁾ °C	5 ⁽⁴⁾	50/55/63 ⁽⁴⁾
Entering/leaving temperature difference at full load ⁽³⁾	-	-

(1) The operating range with evaporator leaving temperatures above 3°C is permitted, but the performances are not optimised.

(2) For lower condenser temperatures a water flow control valve must be installed at the condenser (two-way or three-way). Please refer to option 152 to ensure the correct condensing temperature.

(3) Please refer to chapter 6.6 for the minimum recommended evaporator and condenser flow rate.

(4) Depends on the conditions at the evaporator and the load conditions.

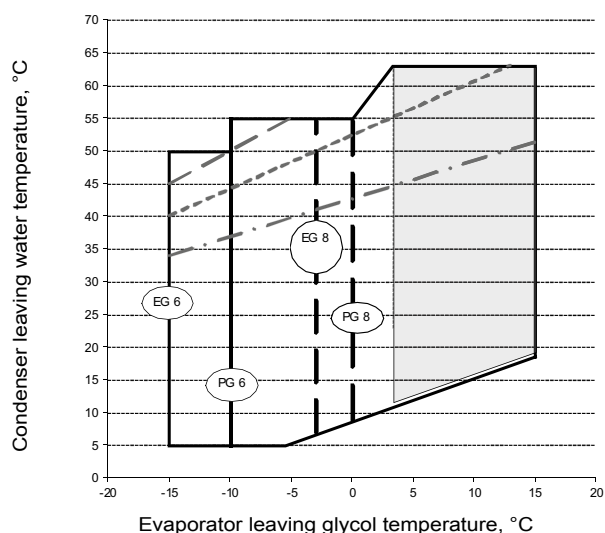

- Operating range permitted, but performances are not optimised
- Full load with option 6/8 and ethylene or propylene glycol
- Part load limit approx. 80%
- Part load limit approx. 50%
- Part load limit approx. 30%

11 - OPTION 33: 90-10 COPPER-NICKEL CONDENSERS

11.1 - Description

Option 33 improves resistance to corrosion thanks to 90/10 Copper Nickel tubes in the condenser. It is recommended if seawater is used at condenser side. The improvement against the corrosion is ensured by a passivation film formed inside the tube.

This film is created when saltwater flows through the system. Condenser tubes and tube sheets are treated. Be aware that water boxes are not treated against corrosion, they are in cast iron.

11.2 - Condenser water flow rate

In order to not prematurely degrade the film, it is recommended to ensure a good water flow rate accordingly to the following table.

Standard-efficiency units 30XW--

Size	254	304	354	402	452	552	602	652	702	802	852	1002	1052	1154	1252	1352	1452	1552	1652	1702	
Condenser water flow rate, l/s																					
Minimum	7	7	7	10	10	10	10	14	14	14	21	19	19	19	31	31	31	31	37	37	
Maximum	14	14	14	20	20	20	20	27	27	27	36	38	38	37	56	56	56	56	74	74	

High-efficiency units 30XW-P

Size	512	562	712	812	862	1012	1162	1314	1464	1612	1762
Condenser water flow rate, l/s											
Minimum	13	13	21	21	21	27	27	31	31	55	55
Maximum	25	25	37	37	37	55	55	56	56	110	110

11.3 - Operating limits with option 33

30XW--/30XW-P	Minimum	Maximum
Evaporator		
Entering temperature at start-up °C	-	35,0
Leaving temperature during operation °C	3,3 ⁽¹⁾	20,0
Entering/leaving temperature difference at full load	2,8 K	11,1 K
Condenser		
Entering temperature at start-up °C	13,0 ⁽²⁾	-
Leaving temperature during operation °C	19,0 ⁽²⁾	45,0 ⁽³⁾

- (1) For low-temperature applications, where the leaving water temperature is below 3.3°C, a frost protection solution must be used. Please refer to option 8 and option 6.
- (2) For lower condenser temperatures a water flow control valve must be used at the condenser (two or three-way valve). Please refer to option 152 to ensure the correct condensing temperature.
- (3) Please refer to option 150 for applications with a high condenser leaving temperature (up to 63°C).

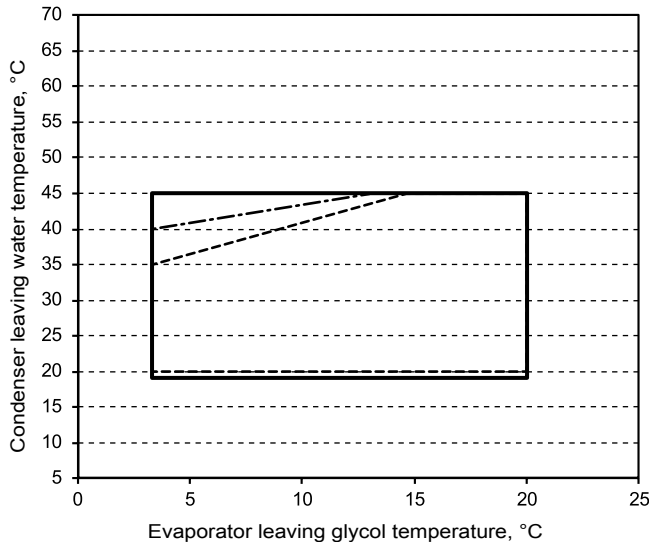

From approx. 45% to full load

- - - - Part load limit approx. 35%
- - - - Minimum load limit approx. 15%

11.4 - Installation and Maintenance

Installation:

If the seawater available for a new system is clean and non-polluted it's circulation through the systems will enable the materials to form protective films which will reduce corrosion rates to very low levels. However, in most fitting-out basins, the seawater is polluted and it is desirable and often essential to take the following precautions to enable the materials to form protective films.

Before the first utilization, the system should be filled initially with fresh water containing 5 ppm ferrous sulphate and this should be left in the system for one day.

The best criterion for correct treatment of a system is appearance of the internal surface of the piping and tubes. This should be red brown in color. The treatments described above can be repeated as often as required to produce such a film and, as ferrous sulphate is a safe inhibitor, no problems are likely to occur from over-dosage.

A proper earth grounding of the system is necessary to minimize the risk of galvanic corrosion due to stray currents.

To ensure a long service life of Copper Nickel tubes, and therefore a good corrosion resistance, it is recommended of not interrupting the water flow for the first two months after start-up, in order to avoid corrosion under deposits (pitting corrosion), and to facilitate the build-up a homogeneous protection layer.

Maintenance:

To improve the lifetime and efficiency of a condenser, it is recommended to inspect internal tube aspect and clean it every 3 months. To facilitate this inspection, removable piping should be installed.

When units are left out of service for more than 2 days, for example during dry-docking or during long voyages, they should be drained and flushed with fresh water, then dried. If left full of seawater, pitting corrosion may develop due to de-oxygenation of the stagnant seawater.

12 - MAJOR SYSTEM COMPONENTS AND OPERATION DATA

12.1 - Direct-drive twin-screw compressor with variable capacity slide valve

- 30XW units use 06T geared twin-screw compressors equipped with a variable capacity slide valve for control between 35% and 100% of full load. For compressor that are able to monitor down to 15%, the stages between 15% and 30% may be continuous or discontinuous.
- The 06T compressor models used are:
06TT-266, 06TT-301, 06TT-356, 06TU-483, 06TU-554, 06TV-680, 06TV-753, 06TV-819

12.1.1 - Oil filter

The 06T screw compressor has an independent oil filter.

12.1.2 - Refrigerant

The 30XW is a liquid chiller operating only with refrigerant R-134a.

12.1.3 - Lubricant

The 06T screw compressor is approved for use with the following lubricant: CARRIER MATERIAL SPEC PP 47-32.

12.1.4 - Oil supply solenoid valve

An oil supply solenoid valve is installed on the oil return line as standard to isolate the compressor from oil flow when the compressor is not operating. The oil solenoid valve is field replaceable.

12.1.5 - Capacity control system

The 06T screw compressor has an unloading system that is standard on all compressors. This unloading system consists of slide valve that permits changing the length of the screw used for the refrigerant compression. This valve is controlled by the action of a piston controlled by two solenoid valves on the oil return line.

12.1.6 - Suction valve (option 92)

An isolating valve can be added to ease maintenance on compressor. This valve can be moved only without pressure differential upstream and downstream of this valve.

12.2 - Pressure vessels

General

Monitoring during operation, re-qualification, re-testing and re-testing dispensation:

- Follow the regulations on monitoring pressurised equipment.
- It is normally required that the user or operator sets up and maintains a monitoring and maintenance file.
- If no regulations exist or to complement regulations, follow the control programmes of EN 378.
- If they exist follow local professional recommendations.
- Regularly inspect the condition of the coating (paint) to detect blistering resulting from corrosion. To do this, check a non-insulated section of the container or the rust formation at the insulation joints.
- Regularly check for possible presence of impurities (e.g. silica grains) in the heat exchange fluids. These impurities maybe the cause of the wear or corrosion by puncture.
- Filter the heat exchange fluid check and carry out internal inspections as described in EN 378.
- In case of re-testing please refer to the maximum operating pressure given on the unit nameplate.
- The reports of periodical checks by the user or operator must be included in the supervision and maintenance file.

Repair

Any repair or modification, including the replacement of moving parts:

- must follow local regulations and be made by qualified operators and in accordance with qualified procedures, including changing the heat exchanger tubes.
- must be made in accordance with the instructions of the original manufacturer. Repair and modification that necessitate permanent assembly (soldering, welding, expanding etc.) must be made using the correct procedures and by qualified operators.
- An indication of any modification or repair must be shown in the monitoring and maintenance file.

Recycling

The unit is wholly or partly recyclable. After use it contains refrigerant vapours and oil residue. It is coated by paint.

Operating life

The evaporator and oil separator are designed for:

- prolonged storage of 15 years under nitrogen charge with a temperature difference of 20 K per day.
- 452000 cycles (start-ups) with a maximum difference of 6 K between two neighbouring points in the vessel, based on 6 start-ups per hour over 15 years at a usage rate of 57%.

Corrosion allowances:

Gas side: 0 mm

Heat exchange fluid side: 1 mm for tubular plates in lightly alloyed steels, 0 mm for stainless steel plates or plates with copper-nickel or stainless steel protection.

12.2.1 - Evaporator

30XW chillers use a flooded multi-tube evaporator. The water circulates in the tubes and the refrigerant is on the outside in the shell. One vessel is used to serve both refrigerant circuits. There is a centre tube sheet which separates the two refrigerant circuits. The tubes are 3/4" diameter copper with an enhanced surface inside and out. There is just one water circuit with two water passes (one pass with option 100C, please refer to chapter 6.5).

The evaporator shell has a polyurethane foam thermal insulation and a water drain and purge.

It has been tested and stamped in accordance with the applicable pressure codes. The maximum standard relative operating pressure is 2100 kPa for the refrigerant-side and 1000 kPa for the water-side. These pressures can be different depending on the code applied. The water connection of the heat exchanger is a Victaulic connection.

The products that may be added for thermal insulation of the containers during the water piping connection procedure must be chemically neutral in relation to the materials and coatings to which they are applied. This is also the case for the products originally supplied by Carrier.

12 - MAJOR SYSTEM COMPONENTS AND OPERATION DATA

12.2.2 - Condenser and oil separator

The 30XW chiller uses a heat exchanger that is a combination condenser and oil separator. It is mounted below the evaporator. Discharge gas leaves the compressor and flows through an external muffler to the oil separator, which is the upper portion of the heat exchanger. It enters the top of the separator where oil is removed, and then flows to the bottom portion of the vessel, where gas is condensed and subcooled. One vessel is used to serve both refrigerant circuits. There is a center tube sheet which separates the two refrigerant circuits. The tubes are 3/4" or 1" diameter internally and externally finned copper tubes.

There is just one water circuit with two water passes (one pass with option 102C, please refer to chapter 6.5). For the Heat Machine units the condenser shell can have a polyurethane foam thermal insulation (option 86) and a water drain and purge.

It has been tested and stamped in accordance with applicable pressure codes. The maximum standard relative operating pressure is 2100 kPa for the refrigerant-side and 1000 kPa for the water-side. These pressures can be different depending on the code applied. The water connection of the heat exchanger is a Victaulic connection.

12.2.3 - Economiser function (depending on model)

The economiser function includes a liquid line valve, a filter drier, two electronic expansion valves (EXVs), a plate heat exchanger as well as protection devices (fuse or valve).

At the condenser outlet a part of the liquid is expanded via the secondary EXV in one of the heat exchanger circuits and then returns as a gas. This expansion permits increase of the liquid sub-cooling of the rest of the flow that penetrates the evaporator via the principal EXV. This permits increasing the cooling capacity of the system as well as its efficiency.

12.3 - Electronic expansion valve (EXV)

The EXV is equipped with a stepper motor (2785 to 3690 steps, depending on the model) that is controlled via the EXV board. The EXV is also equipped with a sightglass that permits verification of the mechanism movement and the presence of the liquid gasket.

12.4 - Moisture indicator

Located on the EXV, permits control of the unit charge and indicates moisture in the circuit. The presence of bubbles in the sight-glass indicates an insufficient charge or non-condensables in the system. The presence of moisture changes the colour of the indicator paper in the sight-glass.

12.5 - Filter drier

The role of the filter drier is to keep the circuit clean and moisture-free. The moisture indicator shows, when it is necessary to change the element. A difference in temperature between the filter inlet and outlet shows that the element is dirty.

12.6 - Sensors

The units use thermistors to measure the temperature, and pressure transducers to control and regulate system operation (see SmartVu™ Control IOM for a more detailed explanation).

12.7 - SRMCR high-pressure safety circuit

General description

The device is equipped with a high pressure safety loop, also known as safety related measurement control and regulation system (SRMCR), consisting of:

- 2 high pressure switches (HPS) with manual reset located at the outlet of each compressor:
 - A pressure switch type PZH
 - A pressure switch type PZHH
- A control relay on the compressor board
- 2 compressor main contactors

See the wiring diagram and bill of material of the unit for details of identification and references.

This safety loop is designed according to EN 61508 for:

SIL level (Safety Integrity): 2

Demand mode: high and low

Mission Time: 20 years.

Periodic test: The safety loop operation must be tested at least once a year to maintain its integrity.

Function description and reset:

Diagram below describes the description of operation: refer to the machine documentation to obtain the detailed wiring diagram

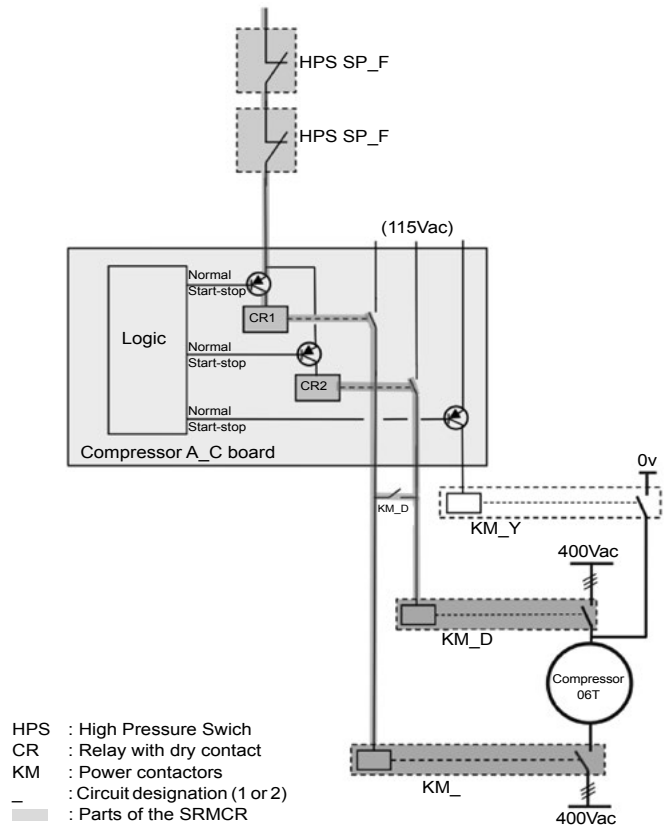

The HPS switches are wired in series to the control relays of the A_C board which controls the KM and KM-D main contactors. Both switches are closed during continuous operation of the compressor. When one of the HPS switches opens, the control relay interrupts the supply voltage of the KM- and KM-D contactor coil: the main contactor opens, which causes the compressor to lose power and stop.

The operation of this safety loop is electromechanical: it is not based on software or an electronic component.

12 - MAJOR SYSTEM COMPONENTS AND OPERATION DATA

Restart after high pressure detection

After detecting the overpressure, it is necessary to manually reset the switched HPS(s). Using a dull tool with a diameter of less than 6 mm if the PZHH HPS is deactivated.

Checks in case of apparent failure of the safety accessory.

If the operating pressure of the unit appears to have been exceeded (for example: after opening of the relief valves), the unit must be stopped immediately. The unit and the safety loop must pass all periodic checks before any possible restart.

If the test reveals any malfunctions that could have led to exceed the maximum allowable pressure (PS) of the device, a complete check of all pressure equipment must be performed to verify their mechanical integrity.

13 - OPTIONS

Options	No.	Description	Advantages	Use for 30XW/ 30XWH range
Low Brine with turbulators down to -15°C	6	Redesigned evaporator including turbulators to allow chilled brine solution production with low pressure drops on the entire negative application range, down to -15°C (including turbulators, extra insulation and algorithms).	Covers specific applications such as ice storage and industrial processes	-0254-1752
Light-brine solution, down to -3°C	8	Implementation of new control algorithms and redesigned evaporator to allow chilled brine solution production down to -3°C when ethylene glycol is used (0°C with propylene glycol)	Matches with most application requirements for ground-sourced heat pumps and fits with many industrial processes requirements	-0254-P1762
IP44 electrical protection level	20	Control box thightness reinforced Electrical box enclosure and outside electrical component following IEC 60529 standard	Permits unit installation in more severe environments	-0254-P1762
90-10 Copper-Nickel condensers	33	- Condenser tubes 90-10 Cu/Ni. - Condenser tube sheets clad with 90-10 Cu/Ni. - Waterboxes not treated against corrosion.	Improved resistance to corrosion	-0254-P1762
Unit supplied in two assembled parts	51	The unit is equipped with flanges that allow disassembly of the unit on site	Facilitates installation in plant rooms with limited access	-1652--1702, P1612-P1762
Master/slave operation	58	Unit equipped with supplementary water outlet temperature sensor kit (to be field installed) allowing master/slave operation of two units connected in parallel	Optimised operation of two units connected in parallel operation with operating time equalisation	-0254-P1762
Single power connection point	81	Unit power connection via one main supply connection	Quick and easy installation	-1002--1702, P1012-P1762
No disconnect switch	82A	Unit without disconnect switch, but with short-circuit protection device	Permits an external electrical disconnect system for the unit (field-supplied), while ensuring unit short circuit protection	-0254-P1762
Evap. single pump power/control circuit	84	Unit equipped with an electrical power and control circuit for one pump evaporator side	Quick and easy installation: the control of fixed speed pumps is embedded in the unit control	-0254--1252, P0512-P1314
Evap. dual pumps power/control circuit	84D	Unit equipped with an electrical power and control circuit for two pumps evaporator side	Quick and easy installation: the control of fixed speed pumps is embedded in the unit control	-0254--1252, P0512-P1314
Cond. single pump power/control circuit	84R	Unit equipped with an electrical power and control circuit for one pump condenser side	Quick and easy installation: the control of fixed speed pumps is embedded in the unit control	-0254--1252, P0512-P1314
Condenser insulation	86	Thermal condenser insulation	Minimizes thermal dispersions condenser side (key option for heat pump or heat recovery applications)	-0254-P1762
Service valve set	92	Liquid line valve (evaporator inlet) and compressor suction line valve	Allow isolation of various refrigerant circuit components for simplified service and maintenance	-0254-P1762
Evaporator with one pass less	100C	Evaporator with one pass on the water side. Evaporator inlet and outlet on opposite sides.	Easy to install, depending on site. Reduced pressure drops	-0254-P1762
Condenser with one pass less	102C	Condenser with one pass on the water side. Condenser inlet and outlet on opposite sides.	Easy to install, depending on site. Reduced pressure drops	-0254-P1762
21 bar evaporator	104	Reinforced evaporator for extension of the maximum water-side service pressure to 21 bar (standard 10 bar)	Covers applications with a high water column evaporator side (typically high buildings)	-0254-P1762
21 bar condenser	104A	Reinforced condenser for extension of the maximum water-side service pressure to 21 bar (standard 10 bar)	Covers applications with a high water column condenser side (typically high buildings)	-0254-P1762
Reversed evaporator water connections	107	Evaporator with reversed water inlet/outlet	Easy installation on sites with specific requirements	-0254-P1762
Reversed condenser water connections	107A	Condenser with reversed water inlet/outlet	Easy installation on sites with specific requirements	-0254-P1762
Lon gateway	148D	Bi-directional communication board complying with Lon Talk protocol	Connects the unit by communication bus to a building management system	-0254-P1762
Bacnet over IP	149	Bi-directional high-speed communication using Bacnet protocol over Ethernet network (IP)	Easy and high-speed connection by ethernet line to a building management system. Allows access to multiple unit parameters	-0254-P1762
Modbus over IP and RS485	149B	Bi-directional high-speed communication using Modbus protocol over Ethernet network (IP)	Easy and high-speed connection by ethernet line to a building management system. Allows access to multiple unit parameters	-0254-P1762

13 - OPTIONS

Options	No.	Description	Advantages	Use for 30XW/ 30XWH range
High condensing temperature	150	Optimized compressor for operation at high condensing temperature	Easy and high-speed connection by ethernet line to a building management system. Allows access to multiple unit parameters	-0254-P1762 except 30XW 0254-0354
Condensing temperature limitation	150B	Limitation of the maximum condenser leaving water temperature to 45°C	Reduced maximum power input and current absorption: power cables and protection elements can therefore be downsized	-0254-P1762
Control for low cond. temperature	152	Output signal (0-10 V) to control the condenser water inlet valve	Simple installation: for applications with cold water at condenser inlet (ex. ground-source, groundwater-source, superficial water-source applications) the signal permits to control a 2 or 3-way valve to maintain condenser water temperature (and so condensing pressure) at acceptable values	-0254-P1762
Dry-cooler control	154	Adaptation of the control box for communication with the dry-cooler via a bus. For dry cooler need to select the cabinet with option control cabinet manage by the chiller control	Easy system management, extended control capabilities of a remote drycooler	-0254-P1762
Energy Management Module	156	EMM Control board with additional inputs/ outputs. See Energy Management Module option chapter	Extended remote control capabilities (Set-point reset, ice storage end, demand limits, boiler on/off command...)	-0254-P1762
7" user interface	158A	Control supplied with a 7 inch colour touch screen user interface	Enhanced ease of use.	-0254-P1762
Input contact for Refrigerant leak detection	159	0-10 V signal to report any refrigerant leakage in the unit directly on the controller (the leak detector itself must be supplied by the customer)	Immediate customer notification of refrigerant losses to the atmosphere, allowing timely corrective actions	-0254-P1762
Dual relief valves on 3-way valve	194	Three-way valve upstream of dual relief valves on the evaporator and the oil separator	Valve replacement and inspection facilitated without refrigerant loss. Comforms to European standard EN378/BGVD4	-0254-P1762
Compliance with Swiss regulations	197	Additional tests on the water heat exchangers: supply (additional of PED documents) supplementary certificates and test certifications	Conformance with Swiss regulations	-0254-P1762
Compliance with Russian regulations	199	EAC certification	Conformance with Russian regulations	-0254-P1762
Compliance with Australian regulations	200	Unit approved to Australian code	Conformance with Australian regulations	-0254-P1762
Low noise level	257	Evaporator sound insulation	3 dB(A) quieter than standard unit	-0402-P1762
Welded evaporator connection kit	266	Victaulic piping connections with welded joints	Easy installation	-0254-P1762
Welded condenser water connection kit	267	Victaulic piping connections with welded joints	Easy installation	-0254-P1762
Flanged evaporator water connection kit	268	Victaulic piping connections with flanged joints	Easy installation	-0254-P1762
Flanged condenser water connection kit	269	Victaulic piping connections with flanged joints	Easy installation	-0254-P1762
Thermal compressor insulation	271	The compressor is covered with a thermal insulation layer	Prevents air humidity to condensate on the compressor surface	-0254-P1762
230V electrical plug	284	230V AC power supply source provided with plug socket and transformer (180 VA, 0,8 Amps)	Permits connection of a laptop or an electrical device during unit commissioning or servicing	-0254-P1762
Free-cooling dry-cooler control	313	Control & connections to a Free Cooling Drycooler 09PE or 09VE fitted with option FC control box	Easy system management, Extended control capabilities to a drycooler used in Free Cooling mode	-0254-P1762
Compliance with Morocco regulation	327	Specifics documents according Morocco regulation	Conformance with Morocco regulations	-0254-P1762

14 - STANDARD MAINTENANCE

Air conditioning equipment must be maintained by professional technicians, whilst routine checks can be carried out locally by specialised technicians. See the standard EN 378-4.

Simple preventive maintenance will allow you to get the best performance from your HVAC unit:

- improved cooling performance
- reduced power consumption
- prevention of accidental component failure
- prevention of major time-consuming and costly interventions
- protection of the environment

There are five maintenance levels for HVAC units, as defined by the AFNOR X60-010 standard.

14.1 - Level 1 maintenance

See note below.

Simple procedure can be carried out by the user:

- Visual inspection for oil traces (sign of a refrigerant leak)
- Check for removed protection devices, and badly closed doors/covers
- Check the unit alarm report when the unit does not work (see report in the SmartVu™ Plus control manual).
- Check the clogging state of filters of aeration openings of the control box.

General visual inspection for any signs of deterioration.

14.2 - Level 2 maintenance

See note below.

This level requires specific know-how in the electrical, hydraulic and mechanical fields. It is possible that these skills are available locally: existence of a maintenance service, industrial site, specialised subcontractor.

In these cases, the following maintenance operations are recommended.

Carry out all level 1 operations, then:

- At least once a year tighten the power circuit electrical connections (see tightening torques table).
- Check and re-tighten all control/command connections, if required (see tightening torques table).
- Check the differential switches for correct operation every 6 months.
- Remove the dust and clean the interior of the control boxes, if required. Check filter cleanliness (if present).
- Check the presence and the condition of the electrical protection devices.
- Replace the fuses every 3 years or every 15000 hours (age-hardening).
- Replace the control box cooling fans (if used) every five years.
- Check the water connections.
- Purge the water circuit (see chapter 7 "Water connections").
- Clean the water filter (see chapter 7 "Water connections").
- Check the unit operating parameters and compare them with previous values.
- Keep and maintain a maintenance sheet, attached to each HVAC unit.

All these operations require strict observation of adequate safety measures: individual protection garments, compliance with all industry regulations, compliance with applicable local regulations and using common sense.

14.3 - Level 3 (or higher) maintenance

See note below.

The maintenance at this level requires specific skills/approval/tools and know-how and only the manufacturer, his representative or authorised agent are permitted to carry out these operations.

These maintenance operations concern for example:

- A major component replacement (compressor, evaporator)
- Any intervention on the refrigerant circuit (handling refrigerant)
- Changing of parameters set at the factory (application change)
- Removal or dismantling of the HVAC unit
- Any intervention due to a missed established maintenance operation
- Any intervention covered by the warranty

NOTE: Any deviation or non-observation of these maintenance criteria will render the guarantee conditions for the HVAC unit null and void, and the manufacturer, Carrier France, will no longer be held responsible.

14.4 - Tightening of the electrical connections

14.4.1 - Tightening torques for the main electrical connections

Screw type	Designation in the unit	Torque value, N·m
Screw on bus bar, customer connection		
M10	L1/L2/L3	40
M12	L1/L2/L3	70
Soldered screw PE, customer connection (M12)		70
Screw on fused disconnect inlet zones		
Fused disconnect 1034061/M10, customer connection	L1/L2/L3	40
Fused disconnect 1034061/M12, Y/D outlet	QS10-	70
Fused disconnect 3KL7141	QS10-	70
Fused disconnect 3KL7151	QS10-	70
Tunnel terminal screw, compressor contactor		
Contacteur 3RT104-	KM-	5
Contacteur 3RT105-	KM-	11
Contacteur 3RT106-	KM-	21
Tunnel terminal screw, current transformer		
Size 2 (3RB2966-)	TI-	11
Compressor earth terminal in the power wiring control box		
M12	Gnd	70
Compressor phase connection terminals		25
M12	1/2/3/4/5/6 on EC-	23
M16	1/2/3/4/5/6 on EC-	30
Compressor earth connection		Gnd on EC- 25
Tunnel terminal screw, water pump disconnect		
Disconnect switch 3RV101-	QM90-	2,5
Disconnect switch 3RV102-	QM90-	2,5
Disconnect switch 3RV103-	QM90-	4
Tunnel terminal screw, water pump contactor		
Contacteur 3RT102-	KM90-	2,5
Contacteur 3RT103-	KM90-	4

14 - STANDARD MAINTENANCE

14.4.2 - Connection precautions for the compressor power terminals

These precautions must be applied during an intervention that requires the removal of the power conductors connected to the compressor supply terminals.

The tightening nut of terminal (6) supporting the isolator (7) must never be loosened, as it ensures terminal tightness and compressor leak tightness.

The tightening of phase lug (4) must apply the torque between counter nut (5) and tightening nut (3): during this operation a counter-torque must be applied at counter nut (5). Counter-nut (5) must not be in contact with the tightening nut of terminal (6).

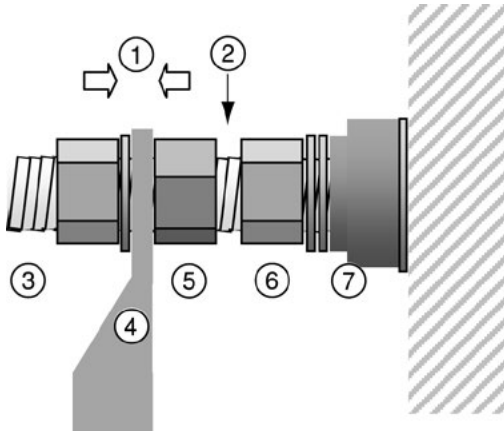

- ① Torque application to tighten the lug
- ② Avoid contact between the two nuts
- ③ Lug tightening nut
- ④ Flat lug
- ⑤ Counter-nut
- ⑥ Terminal tightening nut
- ⑦ Isolator

14.4.3 - Connection precautions for the power contactors

These precautions must be applied for units equipped with 06TUA554, 06TVW753 and 06TVW819 compressors. For these units the power contactor type is 3RT1064 (Siemens).

The contactors allow two connection positions in the cage clamps. But only one position allows safe and reliable tightening on the contactor (KM1 or KM2). The conductor must be positioned in front of the connection area when it is tightened. If it is tightened behind the area, there is a risk that the brackets will be damaged during the tightening.

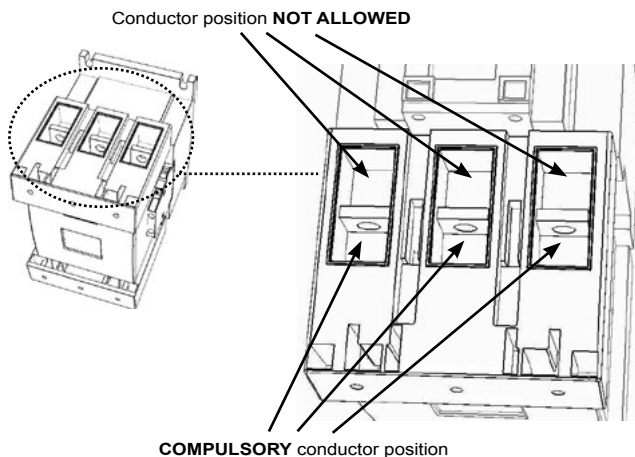

14.5 - Tightening torques for the main bolts and screws

Screw type	Used for	Torque value, N·m
M20 nut	Chassis	190
M20 nut	Heat exchanger side-side connection	240
M16 nut	Compressor fixing	190
H M16 screw	Heat exchanger water boxes, structure	190
H M16 screw	Compressor suction flanges TT	190
H M20 screw	Compressor suction flanges TU & TV	240
M16 nut	Compressor discharge line TT & TU	190
M20 nut	Compressor discharge line TV	240
H M12 screw	Economiser port flange & economiser port valve, option 92	80
H M8 screw	Drier cover	35
1/8 NPT connection	Oil line	12
TE nut	Compressor oil line	24,5
7/8 ORFS nut	Oil line	130
5/8 ORFS nut	Oil line	65
3/8 ORFS nut	Oil line	26
H M6 screw	Stauff collar	10
Taptite screw M6	Oil line collar	7
Taptite screw M6	Brass body, economiser line	10
Metric screw M6	Steel plate fixing, control box, terminal box	7
Taptite screw M10	Oil filter, economiser module, control box fixing	30

14.6 - Evaporator and condenser maintenance

Check that:

- the insulating foam is intact and securely in place,
- the sensors and flow switch are correctly operating and correctly positioned in their support,
- the water-side connections are clean and show no sign of leakage.

14.7 - Compressor maintenance

14.7.1 - Oil filter change schedule

As system cleanliness is critical to reliable system operation, there is a filter in the oil line at the oil separator outlet. The oil filter is specified to provide a high level of filtration (5 µm) required for long compressor life.

The filter should be checked after the first 500 hours of operation, and every subsequent 2000 hours. The filter should be replaced at any time when the pressure differential across the filter exceeds 2 bar.

The pressure drop across the filter can be determined by measuring the pressure at the discharge port (at the oil separator) and the oil pressure port (at the compressor). The difference in these two pressures will be the pressure drop across the filter, check valve, and solenoid valve. The pressure drop across the check valve and solenoid valve is approximately 0.4 bar, which should be subtracted from the two oil pressure measurements to give the oil filter pressure drop.

14.7.2 - Compressor rotation control

Correct compressor rotation is one of the most critical application considerations. Reverse rotation, even for a very short duration, damages the compressor and can even destroy it.

The reverse rotation protection scheme must be capable of determining the direction of rotation and stopping the compressor within one second. Reverse rotation is most likely to occur whenever the wiring at the compressor terminals has been modified.

14 - STANDARD MAINTENANCE

To minimise the opportunity for reverse rotation, the following procedure must be applied. Rewire the power cables to the compressor terminal pin as originally wired. Apply a counter-torque at the lower nut at the supply cable terminal during installation.

For replacement of the compressor, a low pressure switch is included with the compressor. This low pressure switch should be temporarily installed as a hard safety on the high pressure part of the compressor. The purpose of this switch is to protect the compressor against any wiring errors at the compressor terminal pin. The electrical contact of the switch would be wired in series with the high pressure switch. The switch will remain in place until the compressor has been started and direction of rotation has been verified; at this point, the switch will be removed.

The switch that has been selected for detecting reverse rotation is Carrier part number HK01CB001. This switch opens the contacts when the pressure falls below 7 kPa. The switch is a manual reset type that can be reset after the pressure has once again risen above 70 kPa. It is critical that the switch be a manual reset type to preclude the compressor from short cycling in the reverse direction.

14.8 - High pressure safety loop periodic test

In order to verify the full integrity of the safety loop, the following checks have to be performed periodically:

Contactors check

Complete loop operation check

Power contactor check procedure

This procedure shall be applied for each compressor of the unit.

1- Switch off the power of the electrical equipment.

Apply all safety procedures for access to equipment with hazardous voltage.

2- Measure the resistance between upstream and downstream terminals of the main power contactors KM- and KM-D for each phase.

Note: calibrated Ohmmeter shall be used for this task.

3- Confirm resistance is more than 1.0 MOhm.

A resistance lower than 1.0 MOhm, indicates that contactor KM_ or KM_D is defective: further investigations and replacement of the failed part is required.

Illustration for step 2: resistance measurement

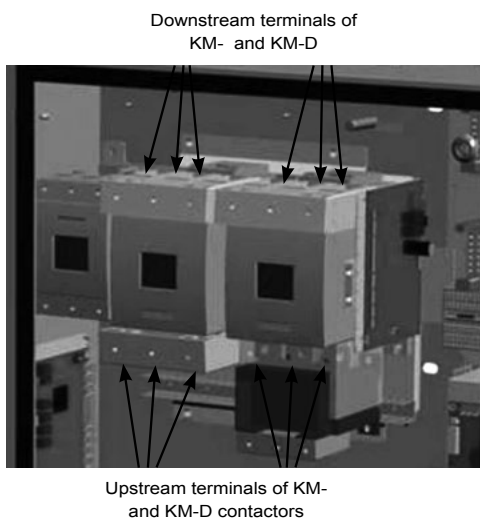

Complete safety loop test

The purpose of this periodic test is to verify the proper functioning and setting of the high-pressure safety loop of a refrigerant circuit.

In order to reach the triggering pressure of the loop, the pressure and temperature thresholds activating the discharge of the compressor by the regulation system are raised.

This procedure must be repeated for each circuit of the unit.

1. Set up a calibrated pressure gauge on the high pressure part of the circuit (compressor discharge)
2. Reset all activated alarms
3. Activate the HP test mode for the corresponding circuit via the control interface.

Enable Quick Test Mode (Quick Test Menu> [QCK_TEST] parameter active)

Activate the high pressure test for the desired circuit (Menu Quick Test> parameter [HP_TEST] to 0 for circuit A or 1 for the B circuit. The corresponding circuit starts to perform the HP test.

4. Getting Started Machine
5. For water-cooled units, stop the circulation of the secondary circuit to the condenser in order to stop the condensation and cause the increase in pressure (this operation is managed by the control on air-cooled machines)
6. Record the trigger value
7. Check that both HPS were triggered
If both HPS have tripped, go to step 10
If only one of the HPS has tripped, go to step 8
8. Replace the triggered HPS with another system whose trigger value is adequate.
Alternatively, an emergency stop button can be installed.
9. Repeat steps 2 to 6
10. Check if the trigger values are correct
The release values should be between $-1.5 / +0.5$ bars of nominal values indicated on the unit.
11. Reset all alarms
12. Reset all HPS

Note:

Access to the maintenance functions can be protected by a password. Contact your dealer or the manufacturer's service department for more information.

For step 8, the electrical disconnection of the triggered HPS and its substitution must be performed in an environment with live parts. All the procedures and authorization provided for this type of intervention must be respected.

The type of connector must be WAGO 231-302 or equivalent.

15 - FINAL SHUTDOWN

15.1 - Shutting down

Separate the units from their energy sources, allow them to cool then drain them completely.

15.2 - Recommendations for disassembly

Use the original lifting equipment.

Sort the components according to their material for recycling or disposal, in accordance with regulations in force.

Check whether any part of the unit can be recycled for another purpose.

15.3 - Fluids to be recovered for treatment

- Refrigerant
- Energy transfer fluid: depending on the installation, water, brine, etc.
- Compressor oil

15.4 - Materials to be recovered for recycling

- Steel
- Copper
- Aluminium
- Plastics
- Polyurethane foam (insulation)

15.5 - Waste electrical and electronic equipment (WEEE)

At the end of its life, this equipment must be disassembled and contaminated fluids removed by professionals and processed via approved channels for electrical and electronic equipment (WEEE).

16 - START-UP CHECKLIST FOR 30XW LIQUID CHILLERS (USE FOR JOB FILE)

Preliminary information

Job name:.....
Location:.....
Installing contractor:.....
Distributor:.....

Unit

Model:.....

Compressors

Circuit A

Model number.....
Serial number.....
Motor number.....

Circuit B

Model number.....
Serial number.....
Motor number.....

Evaporator

Model number.....
Serial number.....

Condenser section

Model number.....
Serial number.....

Additional optional units and accessories.....
.....

Preliminary equipment check

Is there any shipping damage?..... If so, where?.....
.....
Will this damage prevent unit start-up?.....

- Unit is level in its installation
- Power supply agrees with the unit nameplate
- Electrical circuit wiring has been sized and installed properly
- Unit ground wire has been connected
- Electrical circuit protection has been sized and installed properly
- All terminals are tight
- All chilled water valves are open
- All chilled water piping is connected properly
- All air has been vented from the chilled water circuit
- The unit is switched off again, after the pump test has been completed
- Chilled water pump (CWP) is operating with the correct rotation. Check the phase sequence of the electrical connection.
- Circulate chilled water in the water circuit for at least two hours, then remove, clean and replace the screen filter. The unit is switched off again, after the pump test has been completed.
- Inlet piping to cooler includes a 20 mesh strainer with a mesh size of 1.2 mm.

16 - START-UP CHECKLIST FOR 30XW LIQUID CHILLERS (USE FOR JOB FILE)

Unit start-up

- Oil level is correct
 - All discharge and liquid line valves are open
 - Locate, repair and mark all refrigerant leaks
 - All suction valves are open, if used
 - All oil line valves and economizer valves (if used) are open
 - Checks have been carried out for any possible leaks. Unit has been leak checked (including fittings)
 - on the whole unit
 - at all connections
- Locate, repair, and report any refrigerant leaks.....
-
-

- Check voltage imbalance: AB AC..... BC
- Average voltage = V
- Maximum deviation = V
- Voltage imbalance = %
- Voltage imbalance is less than 2%

WARNING: Operation of the chiller with an improper supply voltage or excessive phase imbalance constitutes abuse which will invalidate the Carrier warranty. If the phase imbalance exceeds 2% for voltage, or 10% for current, contact your local electricity supplier at once and ensure that the chiller is not switched on until corrective measures have been taken.

Check cooler water loop

- Water loop volume = litres
- Calculated volume = litres
- 3.25 litres/nominal kW capacity for air conditioning 6.5 litres/nominal kW capacity for process cooling
- Proper loop volume established
- Proper loop corrosion inhibitor included..... litres of
- Proper loop freeze protection included (if required).....litres of.....
- Piping includes electric heater tape, if exposed to temperatures below 0°C
- Inlet piping to cooler includes a 20 mesh strainer with a mesh size of 1.2 mm

Check pressure drop across the cooler

- Entering cooler = kPa
- Leaving cooler = kPa
- Leaving - entering = kPa

WARNING: Plot cooler pressure drop on performance data table (in product data literature) to determine total litres per second (l/s) and find unit's minimum flow rate.

- Total = l/s
- Nominal kW = l/s
- Total l/s is greater than unit's minimum flow rate
- Total l/s meets job specified requirement ofl/s

WARNING: Once power is supplied to the unit, check for any alarms (refer to the SmartVu™ control IOM for the alarm menu).

Note all alarms:.....

.....

NOTE:

The pouch supplied with the unit contains the label indicating the refrigerant used and describing the procedure required under the Kyoto Protocol F-Gas Regulation:

- Attach this label to the machine.
- Follow and observe the procedure described.

Notes:

.....



CARRIER participates in the ECP programme for LCP/HP
Check ongoing validity of certificate:
www.eurovent-certification.com

The quality management system of this product's assembly site has been certified in accordance with the requirements of the ISO 9001 standard (latest current version) after an assessment conducted by an authorized independent third party.

The environmental management system of this product's assembly site has been certified in accordance with the requirements of the ISO 14001 standard (latest current version) after an assessment conducted by an authorized independent third party.

The occupational health and safety management system of this product's assembly site has been certified in accordance with the requirements of the ISO 45001 standard (latest current version) after an assessment conducted by an authorized independent third party.

Please contact your sales representative for more information.

Order No.: 13458, 09.2023 - Supersedes order No.: 13458, 11.2021.

The manufacturer reserves the right to make changes to the product specifications without notice.

Carrier S.C.S, Montluel, France.
Printed in the European Union.