



**INSTALLATION, OPERATION AND
MAINTENANCE INSTRUCTIONS**



**Air-Cooled Liquid Chillers
Reversible heat pumps**

30RB/30RQ 040R-160R

Rated cooling capacity 40-160 kW



* The availability of sizes and options depends on the country. Please contact your local commercial dealer for more information.

CONTENTS

1 - INTRODUCTION AND SAFETY INSTRUCTIONS	4
2 - RECEIPT OF GOODS	4
2.1 - Checking the equipment received	4
3 - HANDLING AND POSITIONING	5
3.1 - Handling	5
3.2 - Positioning	5
4 - DIMENSIONS, CLEARANCES, MINIMUM INSTALLATION DISTANCES	6
4.1 - 30RB/30RQ 040R-080R, units with and without hydraulic module	6
4.2 - 30RB/30RQ 090R-160R, units with and without hydraulic module	7
4.3 - 30RB/30RQ 040R-080R, units with water buffer tank module (Option 307)	8
4.4 - 30RB/30RQ 090R-160R, units with water buffer tank module (Option 307)	9
4.5 - Free spaces and installing several units	10
4.6 - Positioning of potentially flammable zones around the unit	10
5 - PHYSICAL AND ELECTRICAL DATA FOR THE UNITS	11
5.1 - Physical properties: 30RB/30RQ 40R-160R	11
5.2 - Electrical data notes: 30RB/30RQ 040R-160R	14
5.3 - Short circuit current withstand capability	14
5.4 - Electrical data notes for the hydraulic module	15
5.5 - Electrical data notes for the compressors	17
5.6 - Distribution of compressors per circuit	17
5.7 - Comments on electrical data notes	18
6 - ELECTRICAL CONNECTION	19
6.1 - Power supply	19
6.2 - Voltage phase imbalance (%)	19
6.3 - Power connection/disconnect switch	19
6.4 - Recommended cable sections	19
6.5 - Power cable access routing	20
6.6 - Field-installed control wiring	20
6.7 - Electrical power reserve for the user	20
7 - APPLICATION DATA	21
7.1 - Operating range	21
7.2 - Minimum heat transfer fluid flow rate (units without factory-fitted hydraulic module)	24
7.3 - Maximum heat-transfer fluid flow rate (units without factory-fitted hydraulic module)	24
7.4 - Variable flow water type heat exchanger (units without factory-fitted hydraulic module)	24
7.5 - Minimum system water volume	24
7.6 - Maximum system water volume	24
7.7 - Water type heat exchanger water flow rate	25
7.8 - Pressure drop curves for the water exchanger and standard water inlet/outlet piping	25
8 - WATER CONNECTIONS	26
8.1 - Operating precautions and recommendations	26
8.2 - Water connections	27
8.3 - Units without hydraulic module	29
8.4 - Units with hydraulic module and fixed-speed pump (for brine application only)	29
8.5 - Units with hydraulic module and variable-speed pump - pressure differential control	30
8.6 - Units with hydraulic module and variable-speed pump - temperature difference control	31
9 - NOMINAL SYSTEM WATER FLOW RATE CONTROL	32
9.1 - Available static pressure for the installation	32
10 - SYSTEM START-UP	33
10.1 - Checks before system start-up	33
10.2 - Commissioning	33
10.3 - Essential points to check	34

CONTENTS

11 - MAIN COMPONENTS OF THE UNIT AND OPERATING CHARACTERISTICS	35
11.1 - Compressors	35
11.2 - Lubricant.....	35
11.3 - Air-cooled exchanger.....	35
11.4 - Fans.....	36
11.5 - Electronic expansion valve (EXV)	37
11.6 - Moisture indicator	37
11.7 - Filter drier	37
11.8 - Water type heat exchanger.....	37
11.9 - Refrigerant.....	37
11.10 - High-pressure safety pressostat.....	37
11.11 - SmartVu™ control.....	37
12 - OPTIONS	38
12.1 - Tables of options	38
12.2 - Description	40
13 - STANDARD MAINTENANCE	51
13.1 - Maintenance levels.....	51
13.2 - Level 1 maintenance	51
13.3 - Level 2 maintenance	51
13.4 - Level 3 maintenance	52
13.5 - Tightening of the electrical connections	53
13.6 - Tightening torques for the main fastenings	54
13.7 - Air-cooled exchanger.....	54
13.8 - Water type heat exchanger	54
13.9 - Frequency inverter	54
13.10 - Refrigerant volume	55
13.11 - Refrigerant properties.....	55
14 - FINAL SHUTDOWN	56
14.1 - Shutting down.....	56
14.2 - Recommendations for disassembly	56
14.3 - Fluids to be recovered for treatment	56
14.4 - Materials to be recovered for recycling	56
14.5 - Waste Electrical and Electronic Equipment (WEEE).....	56
15 - UNIT START-UP CHECKLIST FOR INSTALLERS PRIOR TO CONTACTING THE MANUFACTURER	57

This manual applies to the following units:

- 30RB standard chiller, R32 refrigerant (A2L fluid)
- 30RQ standard chiller, standard reversible heat pump, R32 refrigerant (A2L fluid)

For operation of the control, please refer to the 30RB/30RQ control manual.

The cover photograph is for illustrative purposes only and is not part of any offer for sale or contract.

1 - INTRODUCTION AND SAFETY INSTRUCTIONS

The units are designed to cool water (for coolers) and cool or reheat water (for reversible heat pumps) for the air conditioning and heating of buildings and industrial processes.

They are designed to provide a very high level of safety and reliability, making installation, start-up, operation and maintenance easier and safer.

They will provide safe and reliable service if used within their application ranges.

For all safety instructions, please refer to the safety manual. A paper version is delivered with the machine, the digital version is available in the same place as the IOM, (contact your local distributor).

In addition to this safety manual, the manufacturer states that the unit is designed for a maximum number of 120,000 start-ups.

These units contain fluorinated greenhouse gases governed by the Kyoto protocol (1997) and subject to European regulation (EU) 2024/573:

- Refrigerant type: R32
- Global Warming Potential (GWP): 675 (AR4)

2 - RECEIPT OF GOODS

2.1 - Checking the equipment received

Check that the unit and the accessories have not been damaged during transport and that no parts are missing. If the unit and the accessories have been damaged or the shipment is incomplete, send a claim to the shipping company.

Compare the name plate data with the order.

The name plate is attached in two places to the unit:

- On one side of the unit exterior,
- On the inside of the electrical panel door.

Check that the IOM corresponds to the unit indicated on the nameplate. If the reference is not the same, contact your distributor.

3 - HANDLING AND POSITIONING

3.1 - Handling

Carrier strongly recommends employing a specialised company to unload the machine.

Do not remove the subbase or the packaging until the unit is in its final position.

These units can be safely moved by trained personnel with a fork lift truck with the correct capacity for the dimensions and weight of the unit, as long as the forks are positioned in the location and direction shown on the unit.

The units can also be lifted with slings, using only the designated lifting points marked on the unit (labels on the chassis and a label with all unit handling instructions, attached to the unit).

Use slings with the correct capacity, and follow the lifting instructions on the certified dimensional drawings supplied.

IMPORTANT: Only attach slings to the designated lifting points which are marked on the unit.

It is advisable to protect coils against crushing while a unit is being moved. Use struts or a lifting beam to spread the slings above the unit. Do not tilt the unit more than 15°.

Safety when lifting can only be guaranteed if all these instructions are followed. Otherwise, there is a risk of equipment damage or injury to personnel.

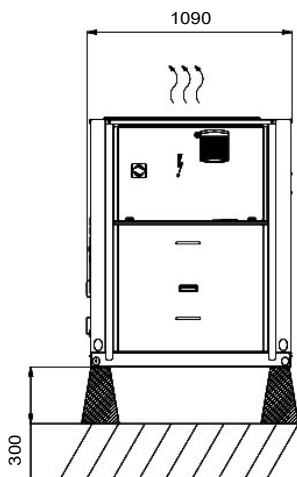

3.2 - Positioning

The machine must be installed in a place that is not accessible to the public and is protected against access by non-authorized persons.

The machine is designed to be installed outdoor.

For more details on the different installation cases, see the A2L refrigerant installation guide.

For extra-high units, the unit environment must permit easy access for maintenance operations.

For the centre of gravity coordinates, the position of the unit mounting holes, and the weight distribution points, refer to the certified dimensional drawings. Ensure the free space shown in the dimensional drawings is respected to facilitate maintenance and connection.

The typical applications of these units are cooling and heating, which do not require earthquake resistance. Earthquake resistance has not been verified.

Before positioning the device, check that:

- The chosen location can support the weight of the unit, or that the appropriate reinforcement measures have been taken.
- The unit is installed level on an even surface (maximum tolerance is 5 mm along both axes).
- If the support structure is sensitive to vibration and/or noise transmission it is advisable to insert anti-vibration mounts (elastomer mounts or metal springs) between the unit and the structure. Selection of these devices is based on the system characteristics and the comfort level required and should be made by technical specialists.
- There is adequate space above and around the unit for air to circulate and for access to the components (see dimensional drawings).
- The number of support points is adequate and that they are in the right places.
- The location is not subject to flooding.
- Wind can affect the operation and performance of machines.
- Avoid installing the unit where snow is likely to accumulate (in areas subject to long periods of sub-zero temperatures, the unit should be raised, see the figure opposite).
- The unit must be installed on a plinth designed to collect then drain the water produced by the reversible units during the defrost cycles. If there is some remaining water on the floor and if temperature is negative, this water could turn into ice and cause falls.
- Baffles may be necessary to deflect strong winds. These must not restrict the unit's air flow.

IMPORTANT: Before lifting the unit, check that all enclosure panels and grilles are securely fixed in place. Lift and set down the unit with great care. Tilting and jarring can damage the unit and impair unit operation.

Never apply pressure or leverage to any of the unit's panels or uprights; only the base of the unit frame is designed to withstand such stresses. No force or effort must be applied to pressurised parts, especially via pipes connected to the water type heat exchanger (with or without the hydraulic module if the unit is equipped with this). The hydraulic module pipes must be fitted so that the pump does not support the weight of the pipes.

All welding operations (connection to the hydraulic network) must be performed by qualified welders. The Victaulic® connection or the counter-flange must be removed before welding as a matter of course.

4 - DIMENSIONS, CLEARANCES, MINIMUM INSTALLATION DISTANCES

4.1 - 30RB/30RQ 040R-080R, units with and without hydraulic module

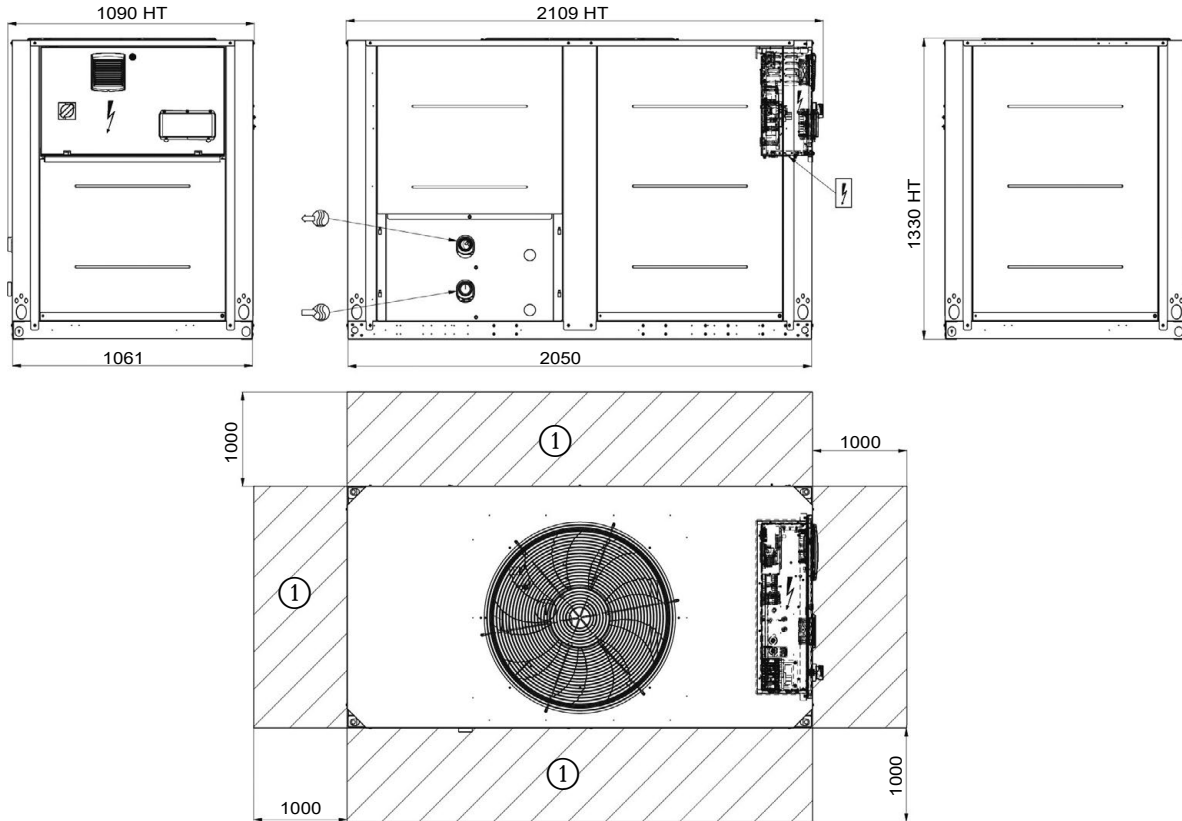

Key:

All dimensions are given in mm.

- ① Clearances required for maintenance and air flow
- ② Clearance recommended for coil removal
- ⊕ Water inlet
- ⊖ Water outlet
- ⋋ Air outlet, do not obstruct
- ⚡ Control box

NOTE: Non-contractual drawings.

When designing a system, refer to the certified dimensional drawings provided with the unit or available on request.

Refer to the nameplate for the machine weight.

Refer to the certified dimensional drawings for:

- The location of the fixing points,
- The weight distribution,
- The coordinates of the centre of gravity, hydraulic and electrical connections,
- Details of the 12/12A/23B option connections.



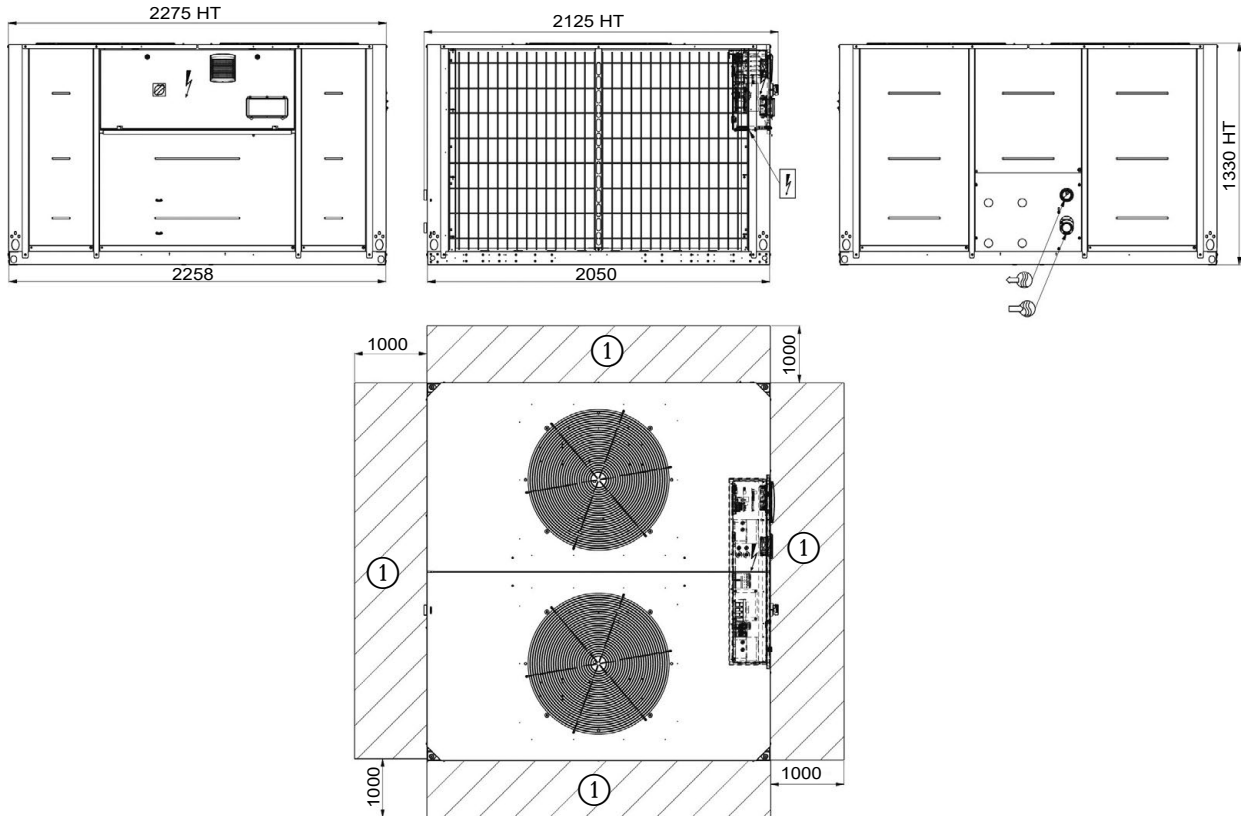

4 - DIMENSIONS, CLEARANCES, MINIMUM INSTALLATION DISTANCES

4.2 - 30RB/30RQ 090R-160R, units with and without hydraulic module



Key:

All dimensions are given in mm.

- ① Clearances required for maintenance and air flow
- ② Clearance recommended for coil removal
-  Water inlet
-  Water outlet
-  Air outlet, do not obstruct
-  Control box

NOTE: Non-contractual drawings.

When designing a system, refer to the certified dimensional drawings provided with the unit or available on request.

Refer to the nameplate for the machine weight.

Refer to the certified dimensional drawings for:



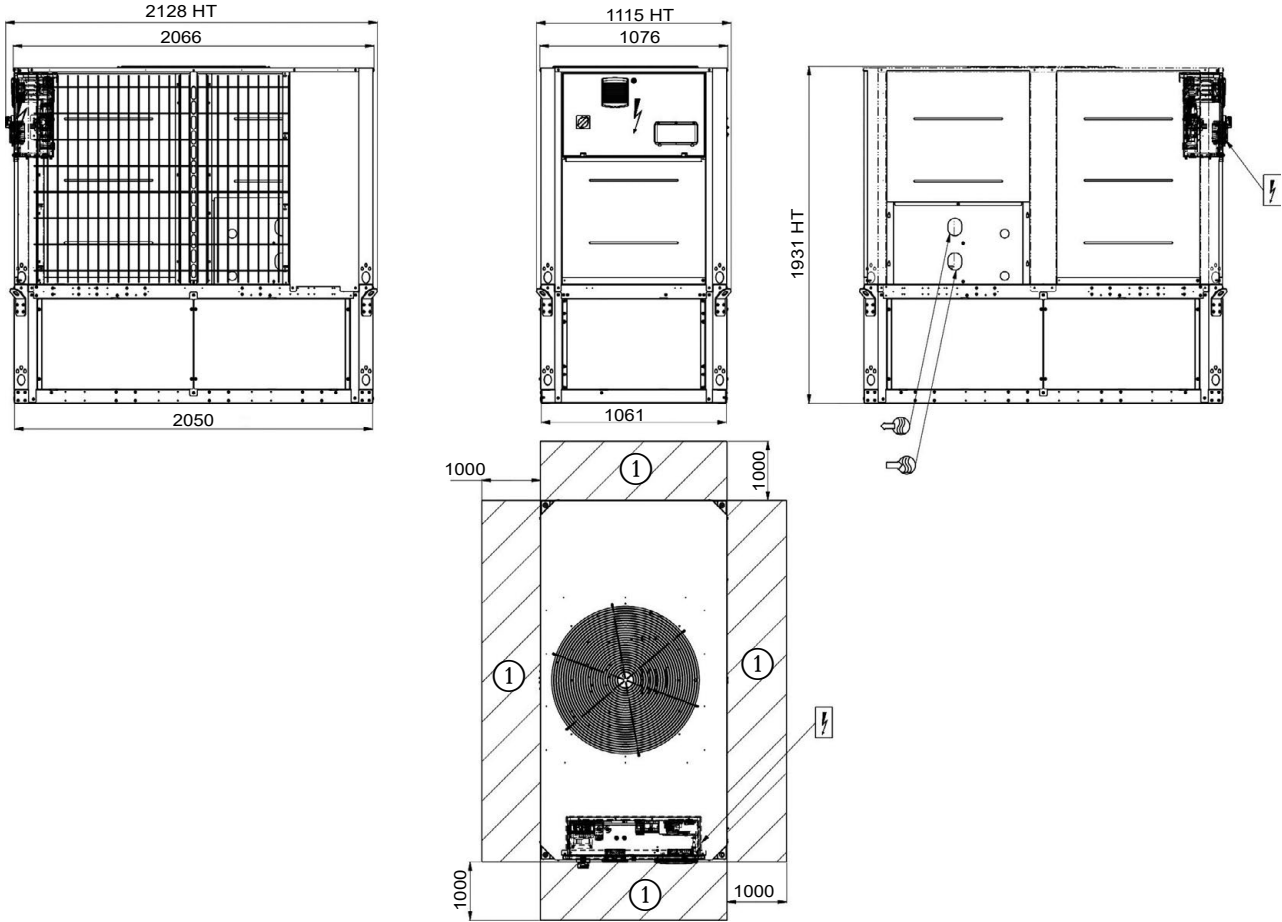

- The location of the fixing points,
- The weight distribution,
- The coordinates of the centre of gravity, hydraulic and electrical connections,
- Details of the 12/12A/23B option connections.

4 - DIMENSIONS, CLEARANCES, MINIMUM INSTALLATION DISTANCES

4.3 - 30RB/30RQ 040R-080R, units with water buffer tank module (Option 307)



Key:
All dimensions are given in mm.

- ① Clearances required for maintenance and air flow
- ② Clearance recommended for coil removal
-  Water inlet
-  Water outlet
-  Air outlet, do not obstruct
-  Control box

NOTE: Non-contractual drawings.

When designing a system, refer to the certified dimensional drawings provided with the unit or available on request.

Refer to the nameplate for the machine weight.

Refer to the certified dimensional drawings for:



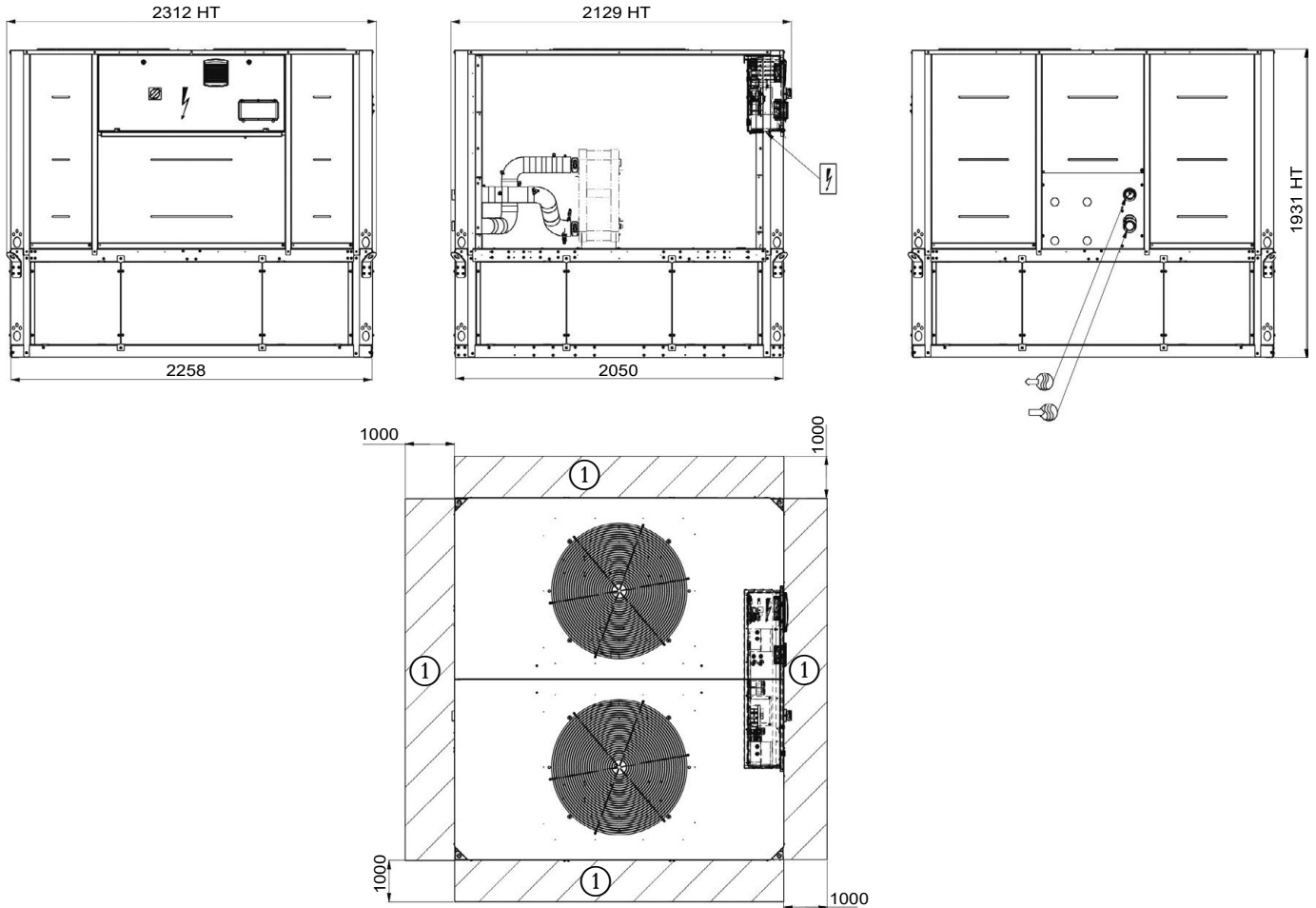

- The location of the fixing points,
- The weight distribution,
- The coordinates of the centre of gravity, hydraulic and electrical connections,
- Details of the 12/12A/23B option connections.

4 - DIMENSIONS, CLEARANCES, MINIMUM INSTALLATION DISTANCES

4.4 - 30RB/30RQ 090R-160R, units with water buffer tank module (Option 307)



Key:
All dimensions are given in mm.

- ① Clearances required for maintenance and air flow
- ② Clearance recommended for coil removal
-  Water inlet
-  Water outlet
-  Air outlet, do not obstruct
-  Control box

NOTE: Non-contractual drawings.

When designing a system, refer to the certified dimensional drawings provided with the unit or available on request.

Refer to the nameplate for the machine weight.

Refer to the certified dimensional drawings for:

- The location of the fixing points,
- The weight distribution,
- The coordinates of the centre of gravity, hydraulic and electrical connections,
- Details of the 12/12A/23B option connections.

4 - DIMENSIONS, CLEARANCES, MINIMUM INSTALLATION DISTANCES

4.5 - Free spaces and installing several units

In multiple-chiller installations (maximum of four units), the free space between the sides of the units should be increased to between 1000 and 2000 mm.

The height of the solid surface must not exceed 2 m.

NOTE: If the walls are higher than 2 m, contact the factory.

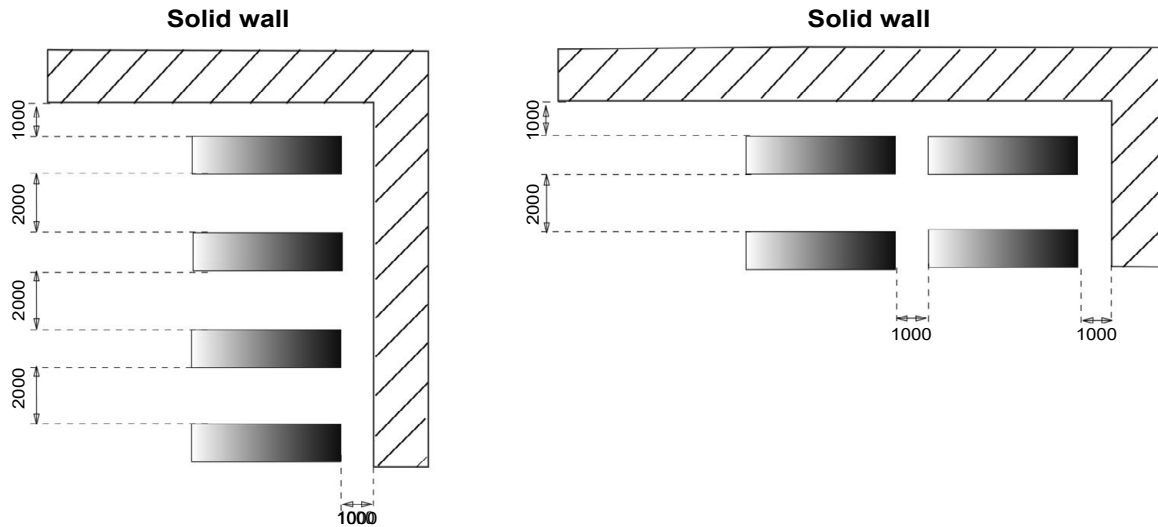

4.6 - Positioning of potentially flammable zones around the unit

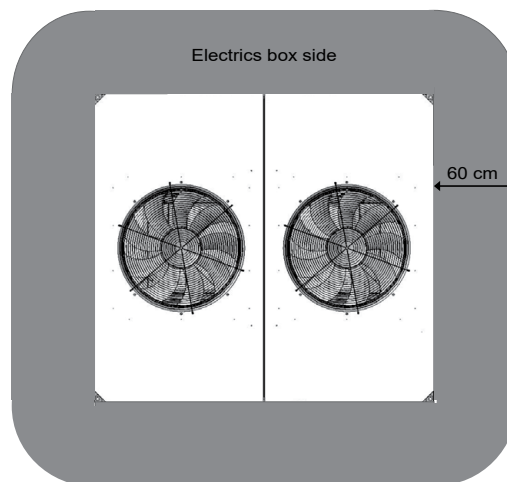

The complete unit, including all the options and accessories which are provided by the manufacturer, have been certified for use with an A2L refrigerant.

To ensure this, the manufacturer complies with EN 378-2 §6.2.14 and has defined a potentially flammable zone using EN 60079-10-1 in order to identify where no sources of ignition must be present.

The manufacturer has then designed the machine so that, if the unit is used in the manner for which it has been designed, there are no internal sources of ignition in the potentially flammable zone inside the machine.

Therefore, the only residual risk is that a source of ignition is introduced into the potentially flammable zone by the user. This is why the manufacturer has decided to show the potentially flammable zone around the machine (see the diagram above) into which the user must not introduce any sources of ignition. This indication is only provided to help our customers to identify the limits of the flammability risk.

However, the machine itself does not present any risk of explosion connected to the use of A2L refrigerant.

Note (the following information is provided by the manufacturer for guidance only. The application of the following directives is the sole responsibility of the user):

In compliance with the directives 2009/104/EC and 1999/92/EC, these zones may be qualified as ATEX Zone by the user on the basis of their own risk analysis, for which they alone remain responsible. In accordance with the definition given by Annex I of the directive 1999/92/EC, this zone may be classified as zone 2 since it may consist of a location where an explosive atmosphere consisting of a mixture of air and flammable substances in the form of a gas is not liable to occur during normal operation or, if it does occur, it only occurs for a short period of time.

If additional equipment is required (motorised valve, pump, etc.), it must be:

- Installed outside of the defined potentially flammable zone
- Certified as not being a source of ignition for the refrigerant used

5 - PHYSICAL AND ELECTRICAL DATA FOR THE UNITS

5.1 - Physical properties: 30RB/30RQ 40R-160R

30RB		040R	045R	050R	055R	060R	070R	080R	090R	100R	120R	140R	160R
Sound levels													
Standard unit													
Sound power ⁽¹⁾	dB(A)	81,0	82,0	83,5	83,5	89,0	89,0	89,0	91,5	91,5	92,0	92,0	92,0
Sound pressure at 10 m ⁽²⁾	dB(A)	50,0	50,5	52,0	52,0	57,0	57,5	57,0	60,0	59,5	60,0	60,0	60,0
Unit + option 15LS													
Sound power ⁽¹⁾	dB(A)	78,0	79,0	80,0	80,0	80,0	80,0	80,0	83,0	83,0	83,0	83,0	83,0
Sound pressure at 10 m ⁽²⁾	dB(A)	47,0	47,5	48,5	48,5	48,0	48,5	48,0	51,0	51,0	51,5	51,0	51,0
Dimensions													
Standard unit													
Length	mm	2109	2109	2109	2109	2109	2109	2109	2275	2275	2275	2275	2275
Width	mm	1090	1090	1090	1090	1090	1090	1090	2125	2125	2125	2125	2125
Height	mm	1330	1330	1330	1330	1330	1330	1330	1330	1330	1330	1330	1330
Unit height (option 12)	mm	1372	1372	1372	1372	1372	1372	1372	1372	1372	1372	1372	1372
Unit height (option 307)	mm	1931	1931	1931	1931	1931	1931	1931	1931	1931	1931	1931	1931
Unit height (option 12 + 307)	mm	1973	1973	1973	1973	1973	1973	1973	1973	1973	1973	1973	1973
Operating weight⁽³⁾													
Standard unit													
Unit + single high-pressure pump option	kg	408	409	428	428	435	446	454	672	734	743	861	877
Unit + dual high-pressure pump option	kg	428	429	448	448	455	466	474	692	754	768	886	902
Unit + single high-pressure pump and buffer tank options	kg	455	456	475	475	482	493	501	719	781	790	908	924
Unit + dual high-pressure pump and buffer tank options	kg	779	781	800	800	807	817	825	1110	1172	1186	1304	1320
Unit + dual high-pressure pump and buffer tank options	kg	806	808	827	827	834	844	852	1137	1199	1208	1326	1342
Compressors													
Hermetic Scroll 48,3 r/s													
Circuit A		2	2	2	2	2	2	2	2	3	3	2	2
Circuit B		-	-	-	-	-	-	-	-	-	-	2	2
No. of power stages		2	2	2	2	2	2	2	2	3	3	4	4
Refrigerant⁽³⁾													
R-32 / A2L/ PRP= 675 in accordance with AR4													
Circuit A	kg	3,72	3,92	4,15	4,60	4,70	4,87	4,84	7,75	8,40	9,00	5,00	5,07
	tCO ₂ e	2,5	2,6	2,8	3,1	3,2	3,3	3,3	5,2	5,7	6,1	3,4	3,4
Circuit B	kg	-	-	-	-	-	-	-	-	-	-	5,00	5,07
	tCO ₂ e	-	-	-	-	-	-	-	-	-	-	3,4	3,4
Oil													
POE													
Circuit A	l	6,00	6,00	6,60	6,60	6,60	7,20	7,20	7,20	10,80	10,80	7,20	7,20
Circuit B	l	-	-	-	-	-	-	-	-	-	-	7,20	7,20
Capacity control													
SmartVu™													
Minimum capacity	%	50	50	50	50	50	50	50	50	33	33	25	25
PED category													
III													
Condenser													
All-aluminium micro-channel coils (MCHE)													
Fans													
Axial Flying Bird 6 with rotating shroud													
Standard unit													
Quantity		1	1	1	1	1	1	1	2	2	2	2	2
Maximum total air flow	l/s	3882	3802	4058	3900	5484	5452	5414	10568	10512	10974	10904	10827
Maximum rotation speed	r/s	12	12	12	12	16	16	16	16	16	16	16	16
Evaporator													
Direct expansion brazed-plate heat exchanger													
Water volume	l	3,55	4	4,44	4,44	5,18	6,07	6,96	7,4	8,44	9,92	12,69	14,31
Max. water-side operating pressure without hydronic module	kPa	1000	1000	1000	1000	1000	1000	1000	1000	1000	1000	1000	1000
Hydronic module (option)													
Pump, Victaulic screen filter, relief valve, water and air vent valve, pressure sensors													
Pump		Centrifugal pump, monocell, 48,3 r/s, low- or high-pressure (as required), single or dual (as required)											
Expansion vessel volume (Option 293) ⁽⁴⁾	L	12	12	12	12	12	12	12	35	35	35	35	35
Buffer tank volume (Option 307)	L	208	208	208	208	208	208	208	208	208	208	208	208
Max. water-side operating pressure with hydronic module	kPa	400	400	400	400	400	400	400	400	400	400	400	400
Water connections with or without hydronic module													
Victaulic® type													
Connections	inches	2	2	2	2	2	2	2	2	2	2	2	2
External diameter	mm	60,3	60,3	60,3	60,3	60,3	60,3	60,3	60,3	60,3	60,3	60,3	60,3
Casing paint colour													
Colour code RAL 7035													

(1) In dB ref=10⁻¹² W, (A) weighting. Declared dual-number noise emission value in accordance with ISO 4871 with an uncertainty of +/-3 dB(A). Measured in accordance with ISO 9614-1 and certified by Eurovent.

(2) In dB ref 20 µPa, (A) weighting. Declared dual-number noise emission value in accordance with ISO 4871 with an uncertainty of +/-3 dB(A). For information, calculated from the sound power Lw(A).

(3) Values are guidelines only. Refer to the unit name plate.

(4) When delivered, the standard pre-infiltration of the tank is not necessarily the optimal value of the system. To permit changing the water volume, change the inflation pressure to a pressure that is close to the static head of the system. Fill the system with water (purging the air) to a pressure value that is 10 to 20kPa higher than the pressure in the tank.

5 - PHYSICAL AND ELECTRICAL DATA FOR THE UNITS

30RQ		040R	045R	050R	060R	070R	080R	090R	100R	120R	140R	160R
Sound levels												
Unit + option 16												
Sound power ⁽¹⁾	dB(A)	82,0	83,0	84,0	89,0	89,5	89,5	92,0	92,0	92,0	92,5	92,0
Sound pressure at 10 m ⁽²⁾	dB(A)	50,0	51,0	52,5	57,5	58,0	58,0	60,5	60,5	60,5	61,0	60,5
Sound power Ecodesign SCOP C conditions		77,0	79,0	83,0	83,5	83,5	81,0	84,5	82,0	82,5	90,0	90,0
Standard unit												
Sound power ⁽¹⁾	dB(A)	82,0	83,0	84,0	89,0	89,5	89,5	92,0	92,0	92,0	92,5	92,0
Sound pressure at 10 m ⁽²⁾	dB(A)	50,0	51,0	52,5	57,5	58,0	58,0	60,5	60,5	60,5	61,0	60,5
Sound power Ecodesign SCOP C conditions		77,0	79,0	83,0	83,5	83,5	81,0	84,5	82,0	82,5	90,0	90,0
Unit + option 15LS⁽³⁾												
Sound power ⁽¹⁾	dB(A)	78,5	79,0	80,5	80,5	80,5	80,5	83,5	83,5	83,5	83,5	83,5
Sound pressure at 10 m ⁽²⁾	dB(A)	47,0	47,5	49,0	49,0	48,5	49,0	52,0	52,0	51,5	52,0	51,5
Sound power Ecodesign SCOP C conditions		74,5	77,0	80,0	81,0	81,0	79,0	82,0	80,0	81,0	86,0	85,0
Dimensions												
Standard unit												
Length	mm	2109	2109	2109	2109	2109	2109	2275	2275	2275	2275	2275
Width	mm	1090	1090	1090	1090	1090	1090	2125	2125	2125	2125	2125
Height	mm	1330	1330	1330	1330	1330	1330	1330	1330	1330	1330	1330
Unit height (option 12)	mm	1372	1372	1372	1372	1372	1372	1372	1372	1372	1372	1372
Unit height (option 307)	mm	1931	1931	1931	1931	1931	1931	1931	1931	1931	1931	1931
Unit height (option 12 + 307)	mm	1973	1973	1973	1973	1973	1973	1973	1973	1973	1973	1973
Operating weight⁽³⁾												
Standard unit	kg	444	446	469	496	506	515	759	818	866	996	1000
Unit + single high-pressure pump option	kg	464	466	489	516	526	535	779	838	891	1021	1025
Unit + dual high-pressure pump option	kg	491	493	516	543	553	562	805	864	923	1054	1058
Unit + single high-pressure pump and buffer tank options	kg	816	818	841	868	878	887	1197	1256	1309	1439	1443
Unit + dual high-pressure pump and buffer tank options	kg	843	845	868	895	905	914	1223	1282	1341	1472	1476
Compressors												
Hermetic Scroll 48,3 r/s												
Circuit A		2	2	2	2	2	2	2	3	3	2	2
Circuit B		-	-	-	-	-	-	-	-	-	2	2
No. of power stages		2	2	2	2	2	2	2	3	3	4	4
Refrigerant⁽³⁾												
R-32 / A2L/ PRP= 675 in accordance with AR4												
Circuit A	kg	7,30	7,30	7,80	8,70	8,95	9,20	15,20	15,70	19,63	8,95	9,15
	tCO ₂ e	4,9	4,9	5,3	5,9	6,0	6,2	10,3	10,6	13,3	6,0	6,2
Circuit B	kg	-	-	-	-	-	-	-	-	-	8,95	9,15
	tCO ₂ e	-	-	-	-	-	-	-	-	-	6,0	6,2
Oil												
Oil type												
Circuit A	l	6,0	6,0	6,6	6,6	7,2	7,2	7,2	10,8	10,8	7,2	7,2
Circuit B	l	-	-	-	-	-	-	-	-	-	7,2	7,2
Capacity control												
SmartVu™												
Minimum capacity	%	50	50	50	50	50	50	50	33	33	25	25

(1) In dB ref=10⁻¹² W, (A) weighting. Declared dual-number noise emission value in accordance with ISO 4871 with an uncertainty of +/-3 dB(A). Measured in accordance with ISO 9614-1 and certified by Eurovent.

(2) In dB ref 20 µPa, (A) weighting. Declared dual-number noise emission value in accordance with ISO 4871 with an uncertainty of +/-3 dB(A). For information, calculated from the sound power Lw(A).

(3) Values are guidelines only. Refer to the unit name plate.

5 - PHYSICAL AND ELECTRICAL DATA FOR THE UNITS

30RQ		040R	045R	050R	060R	070R	080R	090R	100R	120R	140R	160R
Air heat exchanger		Grooved copper tubes and aluminium fins										
Fans		FLYING-BIRD 4, axial fan with rotating impeller										
Standard unit												
Quantity		1	1	1	1	1	1	2	2	2	2	2
Maximum total air flow	l/s	4034	4034	4034	5613	5613	5613	10904	10904	10904	11226	11226
Maximum rotation speed	r/s	12	12	12	16	16	16	16	16	16	16	16
Evaporator		Dual circuit plate heat exchanger										
Water volume	l	3,55	4	4,44	5,18	6,07	6,96	7,4	8,44	9,92	12,69	14,31
Max. water-side operating pressure without hydronic module	kPa	1000	1000	1000	1000	1000	1000	1000	1000	1000	1000	1000
Hydronic module (option)		Pump, Victaulic screen filter, relief valve, water and air drain valve, pressure sensors, expansion tank (option)										
Pump		Centrifugal pump, monocell, 48,3 r/s, low- or high-pressure (as required), single or dual (as required)										
Expansion vessel volume (Option 293) ⁽⁴⁾	L	12	12	12	12	12	12	35	35	35	35	35
Buffer tank volume (Option 307)	L	208	208	208	208	208	208	208	208	208	208	208
Max. water-side operating pressure with hydronic module	kPa	400	400	400	400	400	400	400	400	400	400	400
Water connections with or without hydronic module		Victaulic® type										
Connections	inches	2	2	2	2	2	2	2	2	2	2	2
External diameter	mm	60,3	60,3	60,3	60,3	60,3	60,3	60,3	60,3	60,3	60,3	60,3
Casing paint colour		Colour code RAL 7035 & 7024										

(4) When delivered, the standard pre-infiltration of the tank is not necessarily the optimal value of the system. To permit changing the water volume, change the inflation pressure to a pressure that is close to the static head of the system. Fill the system with water (purging the air) to a pressure value that is 10 to 20kPa higher than the pressure in the tank.

5 - PHYSICAL AND ELECTRICAL DATA FOR THE UNITS

5.2 - Electrical data notes: 30RB/30RQ 040R-160R

30RB/RQ		040R	045R	050R	055R	060R	070R	080R	090R	100R	120R	140R	160R
Power circuit supply													
Nominal voltage	V-ph-Hz	400 - 3 - 50											
Voltage range	V	360 - 440											
Control circuit supply													
24 V via internal transformer													
Maximum operating input power^{(1) or (2)}													
Circuit A&B	kW	19	21	24	24	28	31	36	41	48	55	63	71
Power factor at maximum power^{(1) or (2)}													
Displacement Power Factor (Cos Phi), standard unit													
		0,81	0,82	0,82	0,82	0,84	0,84	0,85	0,82	0,84	0,85	0,84	0,85
Nominal unit current draw⁽⁴⁾													
Standard unit	A	26	29	35	35	36	46	52	59	71	81	91	104
Maximum operating current draw (Un)^{(1) or (2)}													
Standard unit	A	34	37	42	42	48	54	60	72	84	93	108	121
Maximum current (Un-10%)^{(1) or (2)}													
Standard unit	A	37	39	44	44	51	58	65	77	89	99	115	129
Maximum start-up current (Un) ^{(2) + (3)}													
Standard unit	A	116	118	165	165	169	177	191	238	206	223	231	251

(1) Values at the unit's permanent maximum operating condition (as shown on the unit's nameplate).

(2) Values at the unit's maximum operating condition (as shown on the unit's nameplate).

(3) Maximum operating current of the smallest compressor(s) + fan current + locked rotor current of the largest compressor.

(4) Standardised EUROVENT conditions, water-cooled exchanger inlet/outlet = 12°C/7°C, outdoor air temperature = 35°C.

5.3 - Short circuit current withstand capability

Short circuit current withstand capability (TN system⁽¹⁾)

30RB/RQ		040R	045R	050R	055R	060R	070R
Rated short-circuit withstand currents							
Rated short time (1s) current - I _{cw}	kA eff	3,36	3,36	3,36	3,36	3,36	3,36
Rated peak current - I _{pk}	kA pk	20	20	20	20	20	20
Value with upstream electrical protection ⁽¹⁾							
Rated conditional short circuit current I _{cc}	kA eff	40	40	40	40	40	40
Associated protection - type/supplier		Circuit breaker/Schneider					
Associated protection - rating/reference		NS100H	NS100H	NS100H	NS100H	NS100H	NS100H

30RB/RQ		080R	090R	100R	120R	140R	160R
Rated short-circuit withstand currents							
Rated short time (1s) current - I _{cw}	kA eff	5,62	5,62	5,62	5,62	5,62	5,62
Rated peak current - I _{pk}	kA pk	15	20	20	15	20	15
Value with upstream electrical protection ⁽¹⁾							
Rated conditional short circuit current I _{cc}	kA eff	40	40	40	40	30	30
Associated protection - type/supplier		Circuit breaker/Schneider					
Associated protection - rating/reference		NS100H	NS100H	NS160H	NS160H	NS250H	NS250H

(1) If another current limitation protection device is used, its time-current and thermal constraint (I²t) trip characteristics must be at least equivalent to those of the recommended protection.

Note: The short circuit current withstand capability values above have been established for the TN system.

IT system: The short circuit holding current values given above for the TN system are not valid for IT; modifications are required.

5 - PHYSICAL AND ELECTRICAL DATA FOR THE UNITS

5.4 - Electrical data notes for the hydraulic module

The pumps that are factory-installed in these units have motors with efficiency class IE3 for > 0.75 kW motors. The additional electrical data required⁽¹⁾ is as follows:

Motors for unit high-pressure pumps (option 116R, 116S, 116V, 116W)

No. ⁽²⁾	Description ⁽³⁾		040R	045R	050R	055R	060R	070R	080R	090R	100R	120R	140R	160R
1	Nominal efficiency at full load and nominal voltage	%	84,8	84,8	84,8	84,8	84,8	84,8	84,8	84,8	84,8	85,9	85,9	85,9
1	Nominal efficiency at 75% full load and nominal voltage	%	82,2	82,2	82,2	82,2	82,2	82,2	82,2	82,2	82,2	84,0	84,0	84,0
1	Nominal efficiency at 50% full load and nominal voltage	%	79,0	79,0	79,0	79,0	79,0	79,0	79,0	79,0	79,0	82,1	82,1	82,1
2	Efficiency level	-	IE3											
3	Company name or trademark, commercial registration number and head office of manufacturer	-	This information varies depending on the manufacturer and model at the time of incorporation. Please refer to the motor nameplates.											
4	Product model number	-	Same as above											
5	Number of motor poles	-	2											
6-1	Nominal shaft power output at full load and nominal voltage (400 V)	kW	1,70	1,70	1,70	1,70	1,70	1,70	1,70	1,70	1,70	2,20	2,20	2,20
6-2	Maximum input power (400 V) ⁽⁴⁾	kW	2,40	2,40	2,40	2,40	2,40	2,40	2,40	2,40	2,40	2,90	2,90	2,90
	Maximum input power (400V & 40%PG with 6B option) ⁽⁴⁾													
7	Rated input frequency	Hz	50											
8-1	Nominal voltage	V	400											
8-2	Maximum current drawn (400 V) ⁽⁵⁾	A	4,2	4,2	4,2	4,2	4,2	4,2	4,2	4,2	4,2	5,0	5,0	5,0
9	Rated speed	rps - rpm	2870	2870	2870	2870	2870	2870	2870	2870	2870	2855	2855	2855
10	Type of wiring	-	Three-phase											
	Operating conditions for which the motor is specifically designed													
	I - Altitudes above sea level	m	< 1000 ⁽⁶⁾											
11	II - Ambient air temperature	°C	< 40											
	III - Maximum operating temperature	°C	Please refer to the operating conditions given in this manual or in the specific conditions given in the Carrier selection programs.											
	IV - Potentially explosive atmospheres	-	Non-Potentially Flammable environment											

(1) Required by regulation (EU) 2019/1781 concerning the application of directive 2009/125/EC on the eco-design requirements for electric motors.

(2) Item number imposed by regulation (EU) 2019/1781, annex I.2.

(3) Description given by regulation (EU) 2019/1781, annex I.2.

(4) To obtain the maximum input power for a unit with a hydraulic module, add the maximum unit input power from the electrical data table to the pump power input.

(5) To obtain the maximum operating intensity for a unit with a hydraulic module, add the maximum unit current draw from the electrical data table to the pump current draw.

(6) Above 1000 m, a degradation of 3% for each 500 m should be taken into consideration.

5 - PHYSICAL AND ELECTRICAL DATA FOR THE UNITS

Motor for low-pressure single and dual pumps (option 116T, 116U, 116X, 116Y)

No. ⁽²⁾ Description ⁽³⁾		040R	045R	050R	055R	060R	070R	080R	090R	100R	120R	140R	160R
1	Nominal efficiency at full load and nominal voltage	%	81,1	81,1	81,1	81,1	81,1	81,1	81,1	83,4	83,4	84,8	84,8
1	Nominal efficiency at 75% full load and nominal voltage	%	80,8	80,8	80,8	80,8	80,8	80,8	80,8	81,2	81,2	82,2	82,2
1	Nominal efficiency at 50% full load and nominal voltage	%	77,5	77,5	77,5	77,5	77,5	77,5	77,5	78,3	78,3	79,0	79,0
2	Efficiency level	-	IE3										
3	Company name or trademark, commercial registration number and head office of manufacturer	-	This information varies depending on the manufacturer and model at the time of incorporation. Please refer to the motor nameplates.										
4	Product model number	-	Same as above										
5	Number of motor poles	-	2										
6-1	Nominal shaft power output at full load and nominal voltage (400 V)	kW	0,8	0,8	0,8	0,8	0,8	0,8	0,8	1,3	1,3	1,7	1,7
6-2	Maximum input power (400 V) ⁽⁴⁾	kW	1,1	1,10	1,10	1,10	1,10	1,10	1,10	1,60	1,60	2,40	2,40
	Maximum input power (400V & 40%PG with 6B option) ⁽⁴⁾												
7	Rated input frequency	Hz	50										
8-1	Rated voltage	V	3 x 400										
8-2	Maximum current drawn (400 V) ⁽⁵⁾	A	2,1	2,1	2,1	2,1	2,1	2,1	2,1	2,9	2,9	4,2	4,2
9	Rated speed	r/s - r/min	2850	2850	2850	2850	2850	2850	2850	2890	2890	2870	2870
10	Type of wiring	-	Three-phase										
	Operating conditions for which the motor is specifically designed												
11	I - Altitudes above sea level	m	< 1000 ⁽⁶⁾										
	II - Ambient air temperature	°C	< 55										
	III - Maximum operating temperature	°C	Please refer to the operating conditions given in this manual or in the specific conditions in the Carrier selection programs.										
	IV - Potentially explosive atmospheres	-	Non-Potentially Flammable environment										

(1) Required by regulation (EU) 2019/1781 concerning the application of directive 2009/125/EC on the eco-design requirements for electric motors.

(2) Item number imposed by regulation (EU) 2019/1781, annex I.2.

(3) Description given by regulation (EU) 2019/1781, annex I.2.

(4) To obtain the maximum input power for a unit with a hydraulic module, add the maximum unit input power from the electrical data table to the pump power input.

(5) To obtain the maximum operating intensity for a unit with a hydraulic module, add the maximum unit current draw from the electrical data table to the pump current draw.

(6) Above 1000 m, a degradation of 3% for each 500 m should be taken into consideration.

5 - PHYSICAL AND ELECTRICAL DATA FOR THE UNITS

5.5 - Electrical data notes for the compressors

Compressor	I Nom ⁽¹⁾	I Max (Un) ⁽²⁾	I Max (Un - 10%) ⁽³⁾	LRA A ⁽⁴⁾	I start option 25 (A) ⁽⁵⁾	Cos Phi nom. ⁽⁶⁾	Cos Phi Max. ⁽⁷⁾
DSF090	11,5	15,8	17	98	63,7	0,78	0,83
DSF100	13,4	17	18,2	98	63,7	0,79	0,84
DSF115	16,2	19,9	20,5	142	92,3	0,78	0,83
DSF130	15,3	21,6	23,1	142	92,3	0,8	0,86
DSF155	20,2	24,5	26,2	147	95,6	0,81	0,86
DSF175	23,5	27,6	29,7	158	102,7	0,83	0,87
DSF200	24,3	31,1	33,3	197	128,1	0,8	0,85

(1) Nominal current draw (A) under standard Eurovent conditions (see definition of conditions under nominal unit current draw)

(2) Maximum operating current

(3) Maximum compressor operating current, limited by the unit (current given for maximum capacity at 360 V)

(4) Locked rotor current at nominal voltage, corresponding to the direct start-up current

(5) Locked rotor current with electronic starter at nominal voltage

(6) Value at standard Eurovent conditions: evaporator entering/leaving water temperature 12°C/7°C, Outdoor Air Temperature 35°C.

(7) Value recorded at maximum capacity and nominal voltage

5.6 - Distribution of compressors per circuit

Compressor	Circuit	040R	045R	050R	055R	060R	070R	080R	090R	100R	120R	140R	160R
DSF90	A	2											
	B												
DSF100	A		2										
	B												
DSF115	A			2	2								
	B												
DSF130	A					2							
	B												
DSF155	A						2			3		2	
	B											2	
DSF175	A							2			3		2
	B												2
DSF200	A								2				
	B												

5 - PHYSICAL AND ELECTRICAL DATA FOR THE UNITS

5.7 - Comments on electrical data notes

- AquaSnap 30RB/30RQ units have a single power connection point located immediately upstream of the main disconnect switch.

- **The control box includes:**

- A main disconnect switch,
- The start-up and motor protection devices for each compressor, the fans and the pumps,
- The control devices.

- **Field connections:**

All connections to the system and the electrical installations must be in accordance with all applicable codes.

- The AquaSnap 30RB/30RQ units are designed and built to ensure compliance with these regulations. The recommendations of European standard EN 60204-1 (corresponding to IEC 60204-1) (Machine safety - Electrical machine components - part 1: General regulations) are specifically taken into account, when designing the electrical equipment.

- **Notes**

- Generally the recommendations of IEC 60364 are accepted as compliance with the requirements of the installation regulation.
- Compliance with EN 60204-1 is the best means of ensuring compliance (§1.5.1) with the Machinery Directive.
- Annex B of standard EN 60204-1 specifies the electrical features used for the operation of the units.
- The operating conditions for AquaSnap 30RB/30RQ units are described below:
 1. Environment⁽¹⁾
 - The classification of environment is specified in standard EN 60364:
 - Outdoor installation⁽¹⁾,
 - Ambient temperature range: Minimum temperature -20°C to +46°C,
 - Altitude: AC1 of 2000 m or less (for the hydraulic module, see the paragraph "Electrical data notes for the hydraulic module"),
 - Presence of solid foreign bodies: Class AE3 (no significant dust present)⁽¹⁾,
 - Presence of corrosive and polluting substances, class AF1 (negligible),
 - Competence of personnel: BA4 (trained personnel).
 2. Compatibility for low-frequency conducted disturbances at class 2 levels as per the EN IEC 61000-2-4 standard:
 - Power supply frequency variation: +- 2Hz
 - Phase imbalance: 2%
 - Total Voltage Harmonic Distortion (THDV): 8%

3. The neutral (N) line must not be connected directly to the unit (if necessary use a transformer).

4. Overcurrent protection of the power supply conductors is not provided with the unit.

5. The factory installed disconnect switch(es)/circuit breaker(s) is (are) of a type suitable for power interruption in accordance with EN 60947-3 (corresponds to EN IEC 60947-3).

6. The units are designed for connection to TN networks (EN IEC 60364). In IT networks, if noise filters are integrated into the variable frequency drive(s), this will render the machines unsuitable for their intended purpose. In addition, the short-circuit holding current characteristics are modified. Provide a local earth, consult competent local organisations to complete the electrical installation.

AquaSnap 30RB/30RQ machines are designed for use in domestic/residential and industrial environments:

Machines that are not equipped with variable speed drives or equipped with 282A/B options comply with general standards:

- EN IEC 61000-6-3: General standards - Standard emission for residential, commercial and light industry
- EN IEC 61000-6-2: General standards - Immunity for industrial environments

Machines equipped with one or more frequency inverters (options: 6B, 28, 12, 16, 15LS) comply with standards:

- EN IEC 61000-6-4: Emission standard for industrial environments
- EN IEC 61000-6-2: General standards - Immunity for industrial environments

- Leakage currents: If protection by monitoring of leakage currents is necessary to ensure the safety of the installation, the presence of a circuit with a DC component as well as additional leakage currents introduced by the use of variable frequency drives in the unit must be considered (options: 6B, 28, 12, 16, 15LS). In particular, these protections must be:
 - Suited to protecting circuits with AC and DC components.
 - A reinforced immunity type protection with a threshold no lower than 150 mA

Note: If particular aspects of an actual installation do not conform to the conditions described above, or if there are other conditions which should be considered, always contact your local Carrier representative.

(1) The required protection level for this class is IP43BW (according to reference document EN IEC 60529). As all AquaSnap 30RB/30RQ units are class IP44CW, they fulfil this protection condition.

6 - ELECTRICAL CONNECTION

Please refer to the certified dimensional drawings, supplied with the unit.

6.1 - Power supply

The power supply must meet the specification on the unit's nameplate.

The supply voltage must be within the range specified in the electrical data table.

For connections, refer to the wiring diagrams and certified dimensional drawings.

WARNING:

Operation of the unit with an incorrect supply voltage or excessive phase imbalance constitutes misuse which will invalidate the manufacturer's warranty. If the phase imbalance exceeds 2% for voltage, or 10% for current, contact your local electricity supplier at once and ensure that the unit is not switched on until corrective measures have been taken.

After the unit has been started up, the power supply must only be disconnected for quick maintenance operations (one day maximum). For longer maintenance operations or when the unit is taken out of service, the power supply of the unit must be maintained permanently (the heaters must be powered on).

6.2 - Voltage phase imbalance (%)

$$\frac{100 \times \text{max. deviation from average voltage}}{\text{Average voltage}}$$

Example:

On a 400 V - 3 ph - 50 Hz supply, the individual phase voltages were measured with the following values:

AB = 406 V; BC = 399 V; AC = 394 V

$$\begin{aligned} \text{Average voltage} &= (406 + 399 + 394)/3 \\ &= 1199/3 \\ &= 399.7 \text{ (rounded up to 400 V)} \end{aligned}$$

Calculate the maximum deviation from the 400 V average:

$$\begin{aligned} (AB) &= 406 - 400 = 6 \\ (BC) &= 400 - 399 = 1 \\ (CA) &= 400 - 394 = 6 \end{aligned}$$

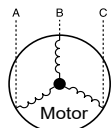

The maximum deviation from the average is 6 V. The greatest percentage deviation is: $100 \times 6/400 = 1.5\%$

This is less than the permissible 2% and is therefore acceptable.

6.3 - Power connection/disconnect switch

The power connection of the unit is carried out at a single point upstream of the unit's disconnect switch.

6.4 - Recommended cable sections

Wire sizing is the responsibility of the installer, and depends on the characteristics and regulations applicable to each installation site. The following is only to be used as a guideline, and does not make the manufacturer in any way liable.

After wire sizing has been completed, using the certified dimensional drawing, the installer must verify the appropriate means of connection and define any modifications necessary on site.

The connections provided as standard for the customer-supplied power supply cables are designed for the number and type of cables listed in the table below.

The calculations of favourable and unfavourable cases are performed by using the maximum current possible for each unit fitted with a hydraulic module (see the tables of electrical data for the unit and the hydraulic module).

The study includes the standardised installation cases according to IEC 60364: Cables with PVC (70°C) or XLPE (90°C) insulation with copper core; routing in accordance with table 52C of the standard.

The maximum length mentioned is calculated to limit the voltage drop to 5%.

IMPORTANT:

Before connecting the main power cables (L1 - L2 - L3), always check 3 phases are in the correct order (clockwise) before proceeding to the connection on the main disconnect switch.

6 - ELECTRICAL CONNECTION

Table of minimum and maximum cable sections (per phase) for connection to the units

30RB/ RQ	Max. connectable section ⁽¹⁾				Calculation of favourable case: - multi-conductor cable wires in the open air (routing modes 34 and 35, method E) - Cable insulated to 90°C - Copper conductor (Cu)			Calculation of unfavourable case: - Conductors in ducts or multi-conductor cables in closed conduits (standardised routing modes, 50, method B1) - Cable insulated to 70°C where possible - Copper conductor (Cu)		
	Section ⁽²⁾	Standard lug	Recommended max. lug width	Bottom connection	Section ⁽²⁾	Max. length for a voltage drop <5%	Cable type ⁽³⁾	Section ⁽²⁾	Max. length for a voltage drop <5%	Cable type ⁽³⁾
	qty x mm ² (per phase)	qty x mm ² (per phase)	mm	qty x mm ² (per phase)	qty x mm ² (per phase)	m	-	qty x mm ² (per phase)	m	-
Standard unit										
040R	1x95	1x95	21	1x95	1x16	278	90°C Cu	1x16	278	70°C Cu
045R	1x95	1x95	21	1x95	1x16	256	90°C Cu	1x16	256	70°C Cu
050R	1x95	1x95	21	1x95	1x16	225	90°C Cu	1x16	225	70°C Cu
055R	1x95	1x95	21	1x95	1x16	225	90°C Cu	1x16	225	70°C Cu
060R	1x95	1x95	21	1x95	1x16	197	90°C Cu	1x16	197	70°C Cu
070R	1x95	1x95	21	1x95	1x16	175	90°C Cu	1x25	271	70°C Cu
080R	1x95	1x95	21	1x95	1x16	158	90°C Cu	1x25	244	70°C Cu
090R	1x95	1x95	21	1x95	1x16	131	90°C Cu	1x35	282	70°C Cu
100R	1x95	1x95	21	1x95	1x16	113	90°C Cu	1x50	340	70°C Cu
120R	1x95	1x95	21	1x95	1x25	157	90°C Cu	1x50	307	70°C Cu
140R	1x95	1x95	21	1x95	1x35	188	90°C Cu	1x70	363	70°C Cu
160R	1x95	1x95	21	1x95	1x35	168	90°C Cu	1x70	324	70°C Cu

(1) Connection capacities actually available for each machine. These are defined according to the connection terminal size, the electrical box access opening dimensions, and the available space inside the electrical box.

(2) Selection simulation result considering the hypotheses indicated.

(3) If the maximum calculated selection is for a 90°C cable type, this means that a selection based on a 70°C cable type can exceed the connection capacity actually available. Special attention must be given to selection.

The protection against direct contact at the electrical connection point is compatible with the addition of fanout cables. The installer must determine whether these are necessary based on the cable sizing calculation.

Note: The currents considered are given for a machine fitted with a hydraulic module in operation at maximum current.

6.5 - Power cable access routing

The power supply must conform to the specification on the chiller nameplate. The supply voltage must be within the range given in the electrical data table. For connections refer to the wiring diagrams and the certified dimensional drawings.

WARNING: Operating the chiller with an incorrect supply voltage or excessive phase imbalance constitutes improper use and will invalidate the Carrier warranty. If the phase imbalance exceeds 2% for voltage, or 10% for current, contact your local electricity supplier at once and ensure that the chiller is not switched on until corrective measures have been taken.

6.6 - Field-installed control wiring

Important: Field connection of interface circuits may lead to safety risks: Any modification to the electrics box must ensure the equipment remains compliant with local regulations. Precautions must be taken to prevent accidental electrical contact between circuits supplied by different sources:

- **The routing selection and/or conductor insulation characteristics must ensure dual electric insulation.**
- **In case of accidental disconnection, conductor fixing between different conductors and/or in the control box prevents any contact between the conductor ends and an active energised part.**

Refer to the 30RB/30RQ SmartVu™ control manual and the certified wiring diagram supplied with the unit for the field control wiring of the following features:

- Evaporator pump interlock (mandatory)
- Remote on/off switch
- Demand limit external switch
- Remote dual setpoint
- Alarm, alert and operation report,
- Heating/cooling selection.

6.7 - Electrical power reserve for the user

Control circuit power reserve:

After all possible options have been connected, the CT transformer ensures the availability of 1 A of power for the control cabling on-site on 24 V, 50 Hz.

7 - APPLICATION DATA

7.1 - Operating range

7.1.1 - 30RB 040R-160R units

Water-cooled heat exchanger		Minimum	Maximum
Entering water temperature at start-up	°C	7,5 ⁽¹⁾	30
Water outlet temperature during operation	°C	5 ⁽²⁾	20 ⁽³⁾
Water outlet temperature during operation (with option 6B)	°C	-8 ⁽²⁾	20 ⁽³⁾
Entering/leaving water temperature difference	K	3	10
Air-cooled exchanger		Minimum	Maximum
Outdoor ambient operating temperature			
30RB units	°C	-10 ⁽⁴⁾	44 ⁽⁵⁾
30RB units - (option 06B, 12, 17, 28, 15LS)	°C	-20 ⁽⁴⁾	44 ⁽⁵⁾
30RB units - (option 16)	°C	-20 ⁽⁴⁾	46 ⁽⁵⁾
Available static pressure (option 12)			
30RB standard	Pa	0	
30RB + option 12 (high-pressure static fans)	Pa	200	
Hydraulic module ⁽⁶⁾		Minimum	Maximum
Air inlet temperature			
Units without frost protection option (option 41/42B)	°C	0	-
Units with frost protection option (option 41/42B)	°C	-20	-

- (1) For an application requiring start-up at less than 7.5°C, contact the manufacturer to select a unit using the electronic catalogue.
- (2) The use of antifreeze is obligatory if the water outlet temperature is below 5°C.
- (3) For applications requiring operation above a water outlet temperature of 20°C, contact the manufacturer to select a unit using the electronic catalogue.
- (4) For operation at an ambient temperature below 0°C, the unit must be equipped with the water exchanger frost protection option (for units without hydraulic module) or the hydraulic module and water exchanger frost protection option (for units with hydraulic module) or the water loop must be protected against frost by the installer, using an antifreeze solution.
- (5) Part load operation permitted below an outdoor air temperature of -10°C and above 44°C. Contact the manufacturer to select a unit using the electronic catalogue.
- (6) Defines the frost-free temperature of the hydraulic components for use without glycol.

Ambient temperatures during shutdown: The 30RB units must be stored and transported at ambient temperatures between -20°C and +51°C. These temperature limits shall be considered in case of container shipment.

**Operating map - Standard unit
30RB 040R-160R**

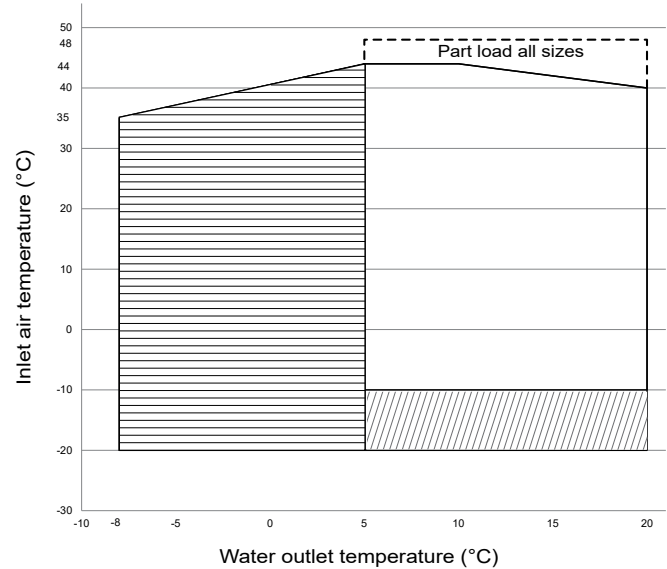

**Operating map - unit 30RB option 16
30RB 040R-160R**

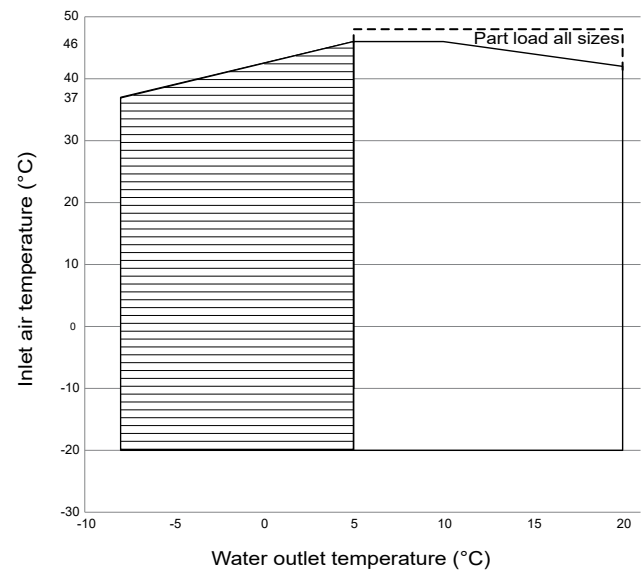

Notes:

1. Water type heat exchanger $\Delta T = 5K$.
2. The unit must either be equipped with the frost protection option for the water heat exchanger and the hydronic module (if used), or the water loop must be protected against frost by the installer using an anti-freeze solution for outdoor air temperatures below 0°C.
3. Operating ranges are guidelines only. Verify the operating range with the electronic catalogue.

Key:

- Operating range at full load
- Extension of the operating range for 30RB unit option 6B, 28, 12, 17, 15LS: Frost protection required (see note 2).
- Operating range of units at partial load.
- Extension of the operating range, unit 30RB option 6B, (see note 2).

7 - APPLICATION DATA

7.1.2 - 30RQ 040R-160R units

Cooling mode

Water-cooled heat exchanger		
	Minimum	Maximum
Entering water temperature at start-up	°C 7,5 ⁽¹⁾	30
Water outlet temperature during operation	°C 5 ⁽²⁾	20 ⁽³⁾
Leaving water temperature during operation 30RQ + Option 119D (Heating Optimized)	°C 6,5	20 ⁽³⁾
Air-cooled exchanger		
	Minimum	Maximum
Outdoor ambient operating temperature		
30RQ units	°C -10 ⁽⁴⁾	44 ⁽⁵⁾
30RQ units - (option 06B, 12, 17, 28, 15LS)	°C -20 ⁽⁴⁾	44 ⁽⁵⁾
30RQ units - (option 16)	°C -20 ⁽⁴⁾	46 ⁽⁵⁾
Available static pressure		
Standard units	Pa	0
Units + Option 12 (high-pressure static fan)	Pa	200

Heating mode

Water-cooled heat exchanger		
	Minimum	Maximum
Entering water temperature at start-up	°C 8 ⁽¹⁾	50
Water outlet temperature during operation	°C 25	55
Leaving water temperature during operation 30RQ + Option 119D (Heating Optimized)	°C 25	60
Air-cooled exchanger		
	Minimum	Maximum
Outdoor ambient operating temperature		
Outdoor ambient temperature at start-up	°C -10 ⁽⁴⁾⁽⁵⁾	35
Available static pressure		
Standard units	Pa	0
Units + Option 12 (high-pressure static fan)	Pa	200

- (1) For an application requiring start-up at less than 8°C, contact the manufacturer to select a unit using the electronic catalogue.
- (2) The use of antifreeze is obligatory if the water outlet temperature is below 5°C.
- (3) For applications requiring operation above a water outlet temperature of 20°C, contact the manufacturer to select a unit using the electronic catalogue.
- (4) For operation at an ambient temperature below 0°C, the unit must be equipped with the water exchanger frost protection option (for units without hydraulic module) or the hydraulic module and water exchanger frost protection option (for units with hydraulic module) or the water loop must be protected against frost by the installer, using an antifreeze solution.
- (5) Partial load operation permitted below an outdoor temperature of -10°C and above 46°C. Contact the manufacturer to select a unit using the electronic catalogue.

Ambient temperatures during shutdown: The 30RQ units must be stored and transported at ambient temperatures between -20°C and +51°C. These temperature limits shall be considered in case of container shipment.

Operating map - cooling mode - Standard 30RQ/Optional 15LS unit

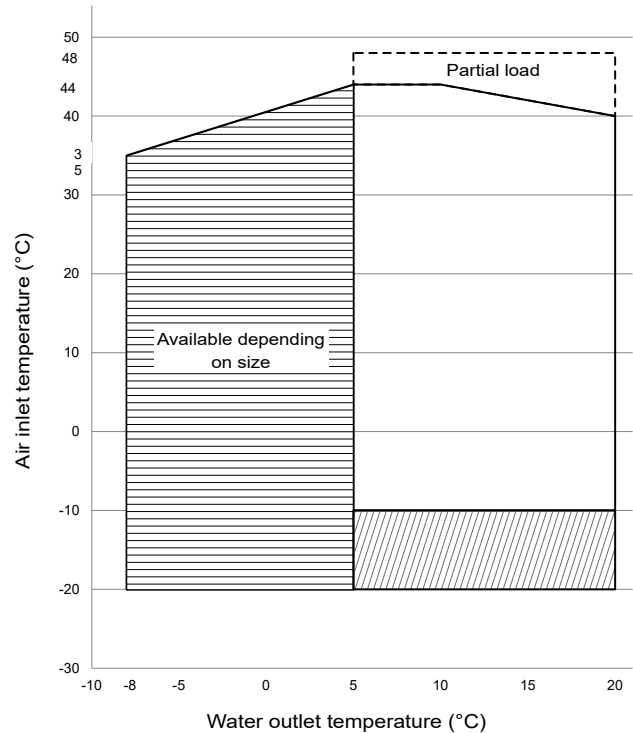

Operating map - cooling mode - 30RQ unit option 16

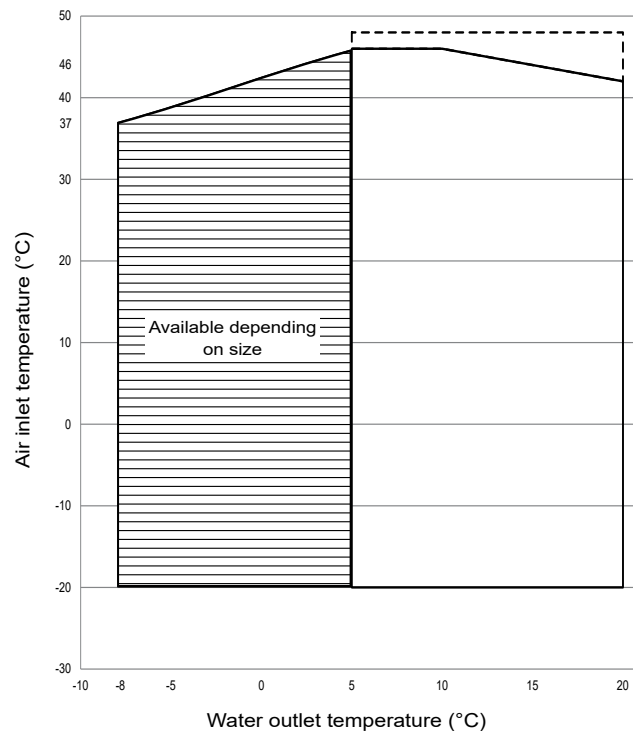

7 - APPLICATION DATA

Operating map - heating mode - Standard unit 30RQ

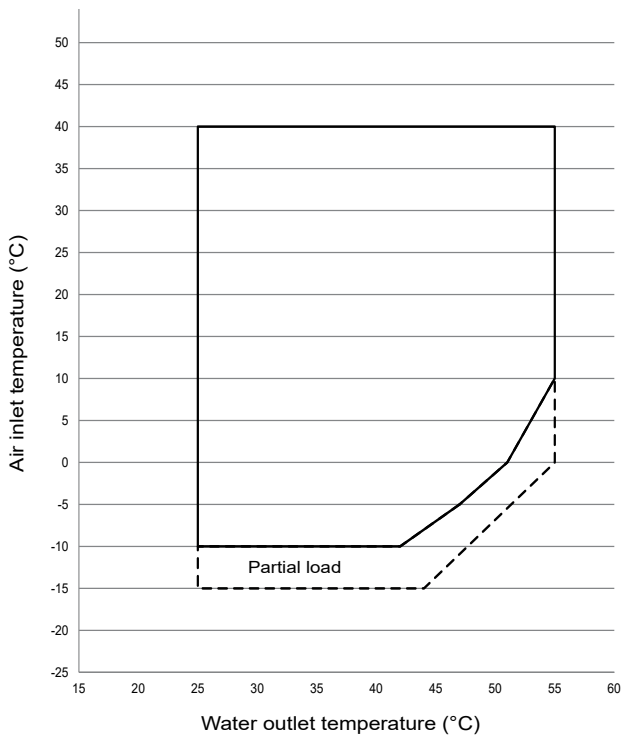

Operating map heating mode - 30RQ - with heating optimized option

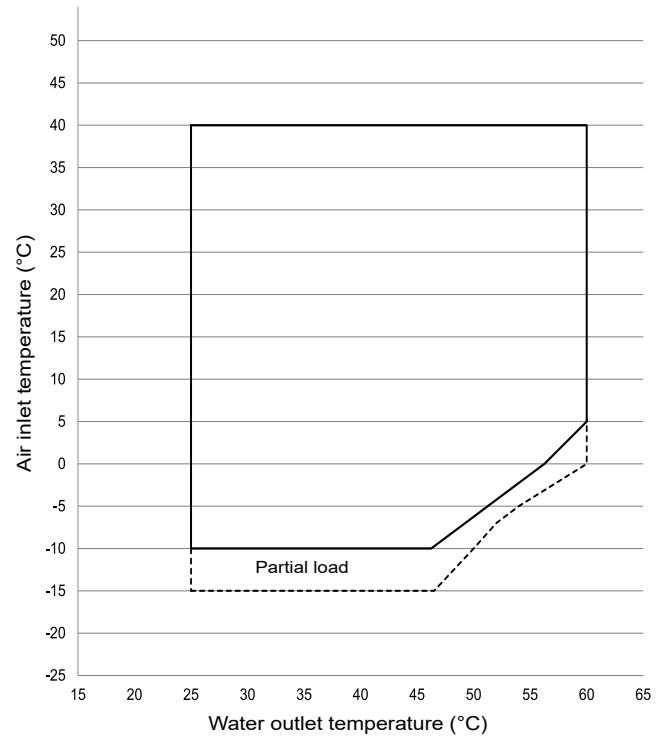

Notes:

1. Water type heat exchanger $\Delta T = 5K$.
2. The unit must either be equipped with the frost protection option for the water heat exchanger and the hydronic module (if used), or the water loop must be protected against frost by the installer using an anti-freeze solution for outdoor air temperatures below 0°C.
3. Operating ranges are guidelines only. Verify the operating range with the electronic catalogue.

Légende:

- Operating range at full load
- Extension of the operating range for 30RQ unit option 6B, 28, 12, 17, 15LS: Frost protection required (see note 2).
- Operating range of units at partial load.
- Extension of the operating range for 30RBQ unit option 6B, (See note 2).

NOTE:

Units equipped with speed regulators (30RB/30RQ option 6B, 12, 15LS, 28, 116V, 116W, 116X, 116Y).

If the air temperature is below -10°C and the unit has been de-energised for more than 4 hours, it is necessary to wait two hours after the unit has been switched on again to allow the regulator to warm up.

Operating map cooling mode - 30RQ - with heating optimized option

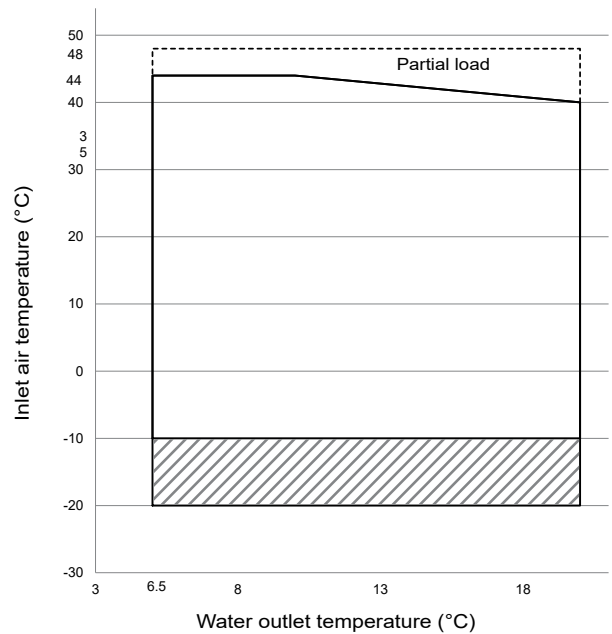

Notes:

1. Water type heat exchanger $\Delta T = 5K$.
2. The unit must either be equipped with the frost protection option for the water heat exchanger and the hydronic module (if used), or the water loop must be protected against frost by the installer using an anti-freeze solution for outdoor air temperatures below 0°C.
3. Operating ranges are guidelines only. The operating range must be checked with the selection software.

Key:

- Operating range at full load.
- Extended operating range 30RB option 28, 12, 17, 15LS: Anti-freeze protection necessary (see note 2)
- Partial load operating range

7 - APPLICATION DATA

7.2 - Minimum heat transfer fluid flow rate (units without factory-fitted hydraulic module)

The minimum heat transfer fluid flow rate for different unit sizes is given in the tables in paragraph "Water type heat exchanger flow rate".

It is determined in order to allow sufficient exchange and prevent the risk of excessive fouling.

If the system flow rate is less than the unit's minimum flow rate, the exchanger flow can be recirculated, as shown in the diagram.

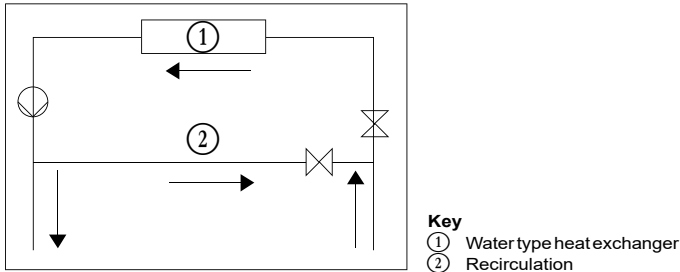

7.3 - Maximum heat-transfer fluid flow rate (units without factory-fitted hydraulic module)

The maximum heat transfer fluid flow rate for different unit sizes is given in the tables in paragraph "Water type heat exchanger flow rate".

This is limited by the permitted exchanger pressure drop. In addition, there must be a minimum Delta T of 3 K, which corresponds to a flow rate of 0.09 l/s per kW.

If the system flow rate exceeds the unit's maximum value, it can be bypassed as shown in the diagram.

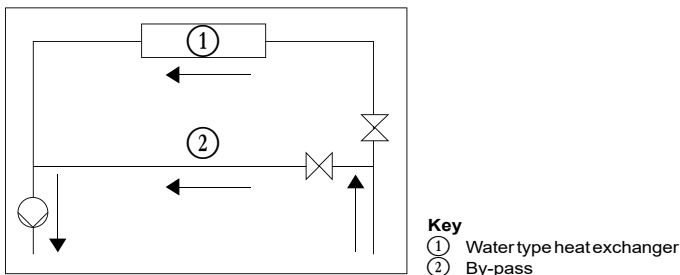

7.4 - Variable flow water type heat exchanger (units without factory-fitted hydraulic module)

A variable water heat exchanger flow can be used in standard units. The flow rate must be higher than the minimum flow given in the table of permissible flow rates and must not vary by more than 10% per minute.

If the flow rate changes more rapidly, the system's water volume should be increased and reach a value of at least 6.5 litres of water per kW.

7.5 - Minimum system water volume

Whichever system, water volume for the water loop (to be provided between the unit and any customer valves outside the machine) is given by the formula

$$\text{Volume} = \text{Cap (kW)} \times \text{N litres}$$

Application	N
Air conditioning – cooling	2,5
Air conditioning – heating	3,0 - 8,0 ⁽¹⁾
Industrial process type cooling	6,5

(1) Depending on the unit capacity - minimum water loop volume 240 l

Where "Cap" represents the cooling or heating capacity (kW) under the installation's nominal operating conditions. This volume is necessary for stable operation. It may be necessary to add a buffer water tank to the circuit in order to achieve the minimum volume. The tank must itself be internally baffled in order to ensure proper mixing of the liquid (water or brine). Refer to the examples below.

Connection to a buffer tank

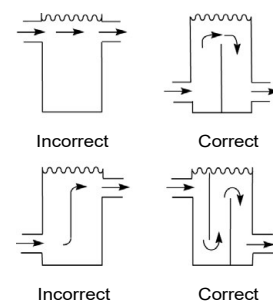

7.6 - Maximum system water volume

Units supplied with a hydraulic module may include an expansion tank which limits the volume in the water loop (option 293).

The table below gives the maximum loop volume compatible with the expansion vessel (for pure water or ethylene glycol depending on the system's various concentrations and static pressures). In the case of the optional buffer tank (option 307-), the volume of the tank (208 litres) must be subtracted from this max. water volume. If this volume is less than the volume of the loop installed, then an additional expansion vessel must be added to the installation.

RB-/RQ-		040-080			090-160		
Static pressure	bar	1	2	3	1	2	3
Pure water	l	595	397	198	1736	1157	579
10% EG	l	471	314	157	1373	915	458
20% EG	l	389	259	130	1135	757	378
30% EG	l	348	232	116	1014	676	338
40% EG	l	289	193	96	843	562	281

EG: Ethylene Glycol

7 - APPLICATION DATA

7.7 - Water type heat exchanger water flow rate

Data applicable for pure water.

30RB/RQ 040R-160R units

30RB/RQ	Minimum	Maximum ⁽¹⁾	Dual-pump ⁽²⁾ High pressure ⁽³⁾
040R	0,9	3	3,4
045R	0,9	3,4	3,8
050R	0,9	3,7	4
055R	0,9	3,7	4
060R	0,9	4,2	4,4
070R	1	5	5
080R	1,2	5,5	5,2
090R	1,3	6,8	6,2
100R	1,5	7,7	6,5
120R	1,7	8,5	8
140R	2	10,6	8,7
160R	2,3	11,2	8,9

(1) Minimum flow rate for maximum allowable water temperature difference conditions (10K) under Eurovent conditions

(2) Maximum flow rate for a pressure drop of 100 kPa in the plate heat exchanger

(3) Maximum flow rate with a single pump is 2% to 4% higher based on its size in the IOM

7.8 - Pressure drop curves for the water exchanger and standard water inlet/outlet piping

Data applicable for pure water at 20°C.

30RB/RQ 040R-160R units

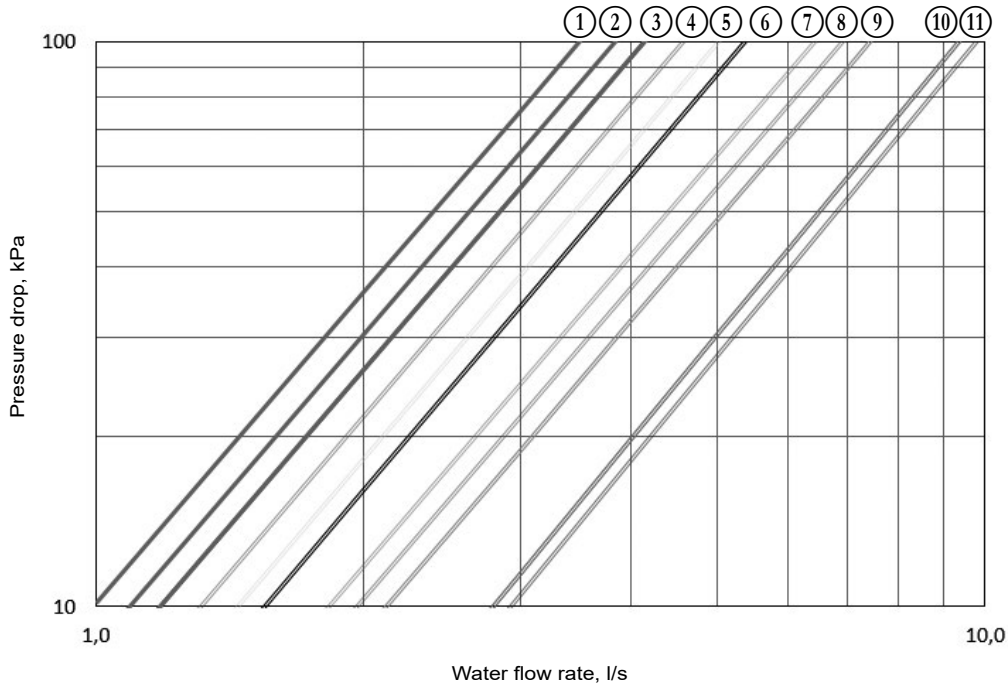

- ① 30RB/RQ - 040R
- ② 30RB/RQ - 045R
- ③ 30RB/RQ - 050R - 55R
- ④ 30RB/RQ - 060R
- ⑤ 30RB/RQ - 070R
- ⑥ 30RB/RQ - 080RWW

- ⑦ 30RB/RQ - 090R
- ⑧ 30RB/RQ - W100R
- ⑨ 30RB/RQ - 120R
- ⑩ 30RB/RQ - 140R
- ⑪ 30RB/RQ - 160R

8 - WATER CONNECTIONS

When connecting units to the water distribution pipe work, refer to the certified dimensional drawings supplied with the unit for the dimensions and position of the water inlet and outlet connections. The piping must not transmit any axial or radial force to the exchangers, or any vibrations.

The water must be analysed and the circuit must include provision of any necessary water treatment: Filters, additives, intermediate exchangers, bleed valves, vents, shut-off valves, etc. depending on the results, in order to prevent corrosion (e.g. damage to the surface of the tubes due to impurities in the fluid), fouling and deterioration of the pump lining.

Before any start-up, make sure the heat-transfer fluid is compatible with the water circuit materials and coating. Where additives or fluids other than those recommended by the manufacturer are used, ensure that these are not considered gases, and that they are class 2, as defined in directive 2014/68/EU.

Manufacturer's recommendations concerning heat transfer fluids:

- Cl⁻ Chloride ions are also harmful to copper with a risk of perforating corrosion. Keep at a level below 25 mg/l. Regarding the desuperheater options, the level of chloride ions (Cl⁻) must be kept below 10 mg/l.
- SO₄²⁻ sulphate ions can cause perforating corrosion, if their content is above 30 mg/l.
- No fluoride ions (< 0.1 mg/l).
- No Fe²⁺ and Fe³⁺ ions with non negligible levels of dissolved oxygen must be present. Dissolved iron < 5 mg/l with dissolved oxygen < 5 mg/l.
- Dissolved silicon: Silicon is an acid element of water and can also lead to corrosion risks. Content < 1 mg/l.
- Water hardness: > 0.5 mmol/l. Values between 1 and 2.5 are recommended. This will facilitate scale deposits that can limit the corrosion of copper. Values that are too high can cause piping blockage over time. A total alkalimetric titre (TAC) below 100 mg/l is desirable.
- Dissolved oxygen: Avoid any sudden change in water oxygenation conditions. It is as detrimental to deoxygenate the water by mixing it with inert gas as it is to over-oxygenate it by mixing it with pure oxygen. The disturbance of the oxygenation conditions encourages destabilisation of copper hydroxides and enlargement of particles.
- Electric conductivity 10-600 µS/cm.
- pH: Ideal case pH neutral at 20-25°C (7.5 < pH < 9).

IMPORTANT: *Filling, topping up or emptying of the water circuit must be carried out by qualified personnel using the air bleed devices and tools and equipment suitable for the products.*

The heat-transfer fluid should be filled and drained using devices fitted to the water circuit by the installer. Never use the unit heat exchangers to add heat-transfer fluid.

8.1 - Operating precautions and recommendations

Before commissioning, make sure the hydraulic circuits are connected to the appropriate heat exchangers.

The water circuit must have as few bends and horizontal sections at different levels as possible,

Main points to be checked for the connection:

- Make sure that the stainless steel water filter is in the screen filter. (See figure 2).
- Comply with the water inlet and outlet connections shown on the unit.
- Install manual or automatic air purge valves at all high points in the circuit.
- Maintain the pressure of the circuit(s) with a pressure-reducing valve and install a relief valve and an expansion vessel. Units supplied with a hydraulic module include a valve. The expansion vessel is supplied as an option.
- Install thermometers in both the water inlet and outlet pipes.
- Install drain connections at all low points to allow the whole circuit to be drained.
- Install shut-off valves close to the water inlet and outlet connections.
- Use flexible connections to reduce the transmission of vibrations.
- Insulate the cold water pipework, after testing for leaks, to prevent heat transmission and condensation.
- Cover the insulation with a vapour barrier. If the water pipes outside the unit pass through an area where the ambient temperature is likely to fall below 0°C, it must be protected against frost (antifreeze solution or electric heaters)
- Do not introduce any static or dynamic pressure into the heat exchange circuit which significantly deviates from the design operating pressures.
- The use of different metals in the hydraulic system may create galvanic couples and lead to corrosion. Verify the need to install sacrificial anodes.
- Products used for thermal insulation of recipients during hydraulic connection must be chemically neutral to the surfaces on which they are applied. All original materials supplied by the manufacturer comply with this requirement.

Note:

A screen filter must be installed for units supplied without a hydraulic module. This must be installed on the water inlet pipe, upstream of the pressure differential gauge and close to the unit heat exchanger. It must be located somewhere easily accessible to enable disassembly and cleaning.

The mesh size of the filter must be no more than 1.2 mm.

If the filter is missing, the plate heat exchanger can quickly become fouled during the first start-up, as it will trap any debris in the system, and correct unit operation will be affected (reduced water flow rate due to the increased pressure drop).

Units with a hydraulic module are equipped with this type of filter.

Protection against cavitation (option 116):

To ensure the durability of the pumps in the integrated hydraulic modules, the control algorithm of the unit incorporates anti-cavitation protection.

It is therefore necessary to ensure a minimum pump entering pressure of 60 kPa (0.6 bar) during operation and at shut-down.

A pressure below 60 kPa will prohibit unit start-up or cause an alarm with the unit shutting down.

8 - WATER CONNECTIONS

8.2 - Water connections

The hydraulic module options are only compatible with closed loops.

The use of the hydraulic module on open systems is prohibited.

Schematic diagram of the hydraulic circuit without the hydraulic module

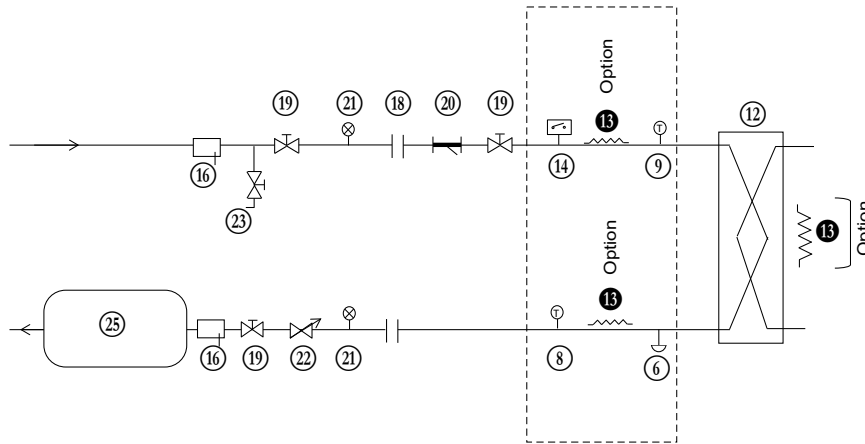

Schematic diagram of the hydraulic circuit with the hydraulic module

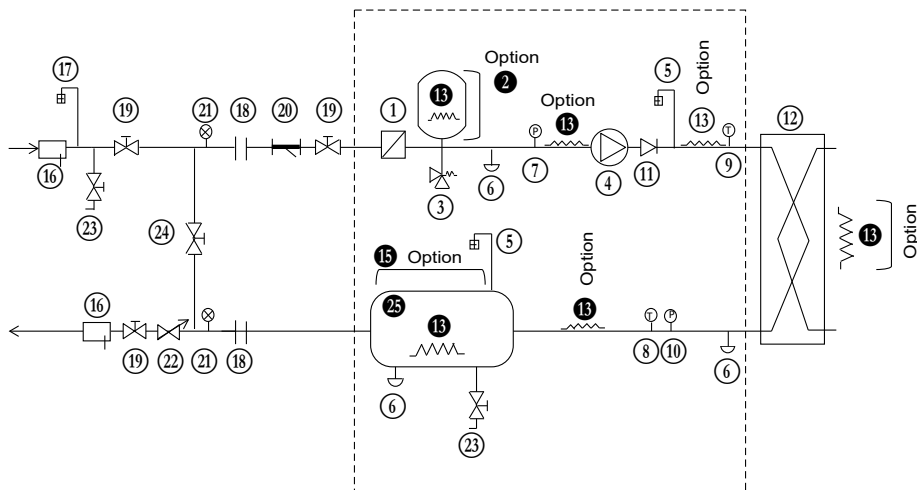

Key

Components of the unit and hydronic module

- ① Screen filter (particle size of 1.2 mm)
- ② Expansion tank (option)
- ③ Relief valve
- ④ Circulating pump (single or dual)
- ⑤ Air vent
- ⑥ Water drain tap
- ⑦ Pressure sensor
- Note: Provides pressure information for the pump inlet (see Control manual)**
- ⑧ Temperature probe
- Note: Provides temperature information for the water exchanger outlet (see Control manual)**
- ⑨ Temperature probe
- Note: Provides temperature information for the water exchanger inlet (see Control manual)**
- ⑩ Pressure sensor
- Note: Provides pressure information for the water exchanger outlet (see Control manual)**
- ⑪ Check valve (If dual pump)
- ⑫ Plate heat exchanger
- ⑬ Heater or heat trace cable for frost protection (Option)
- ⑭ Water type heat exchanger flow rate sensor
- ⑮ Buffer Tank Module (Option)

Installation components

- ⑬ Pocket
- ⑬ Air vent
- ⑬ Flexible connection
- ⑬ Shut-off valve
- ⑬ 800 µm screen filter (mandatory for a unit without a hydraulic module)
- ⑬ Pressure gauge
- ⑬ Water flow control valve
- ⑬ Charge valve
- ⑬ Bypass valve for frost protection (if shut-off valves are closed (item 19) during winter)
- ⑬ Buffer tank (if required)
- Hydronic module (unit with hydronic module option)

Notes:

- **The system must be protected against frost.**
- **The unit's hydronic module and the water type heat exchanger may be protected (factory-fitted option) against freezing using electric heaters and heat trace cables (13)**
- **The pressure sensors are assembled on connections without Schrader. Depressurise and drain the system before any work.**

8 - WATER CONNECTIONS

Hydraulic module - sizes 039-080
Dual pump and expansion vessel

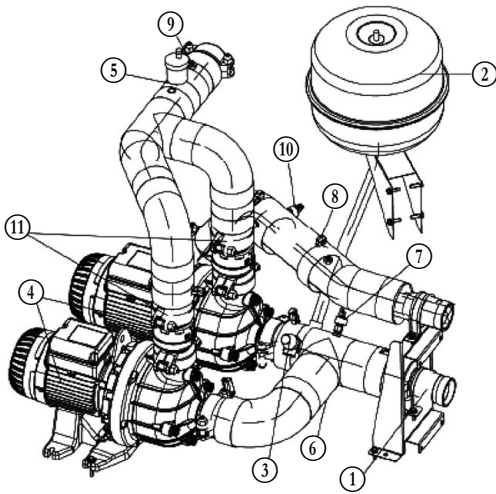

Hydraulic module - sizes 090-160
Dual pump and expansion vessel

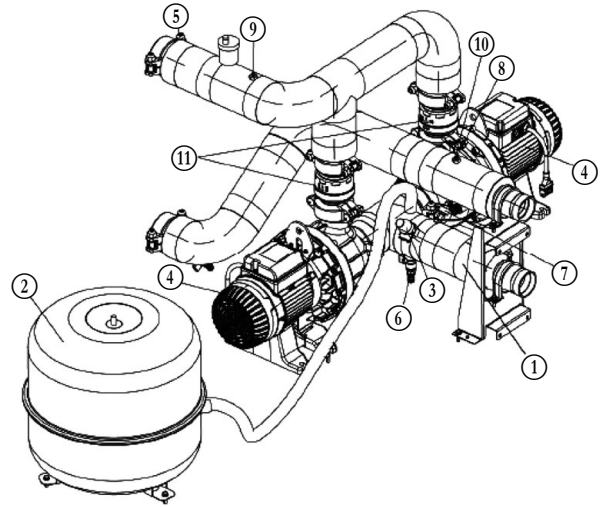

Hydraulic module - sizes 040R-080R
Dual pump, expansion vessel
and buffer tank shown

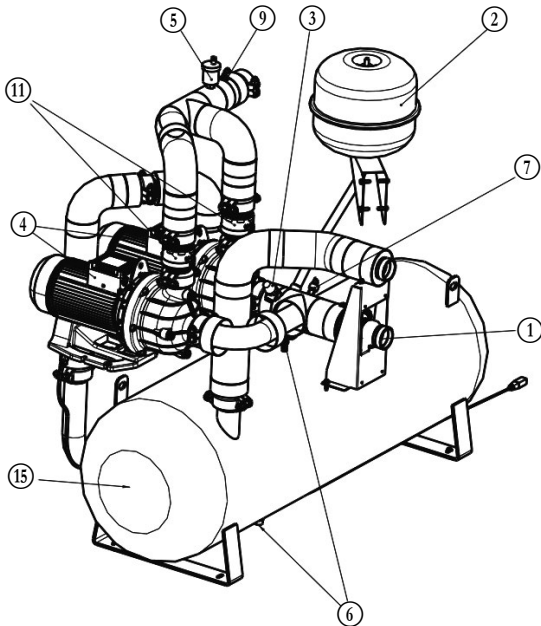

Hydraulic module - sizes 090R-160R
Dual pump, expansion vessel
and buffer tank shown

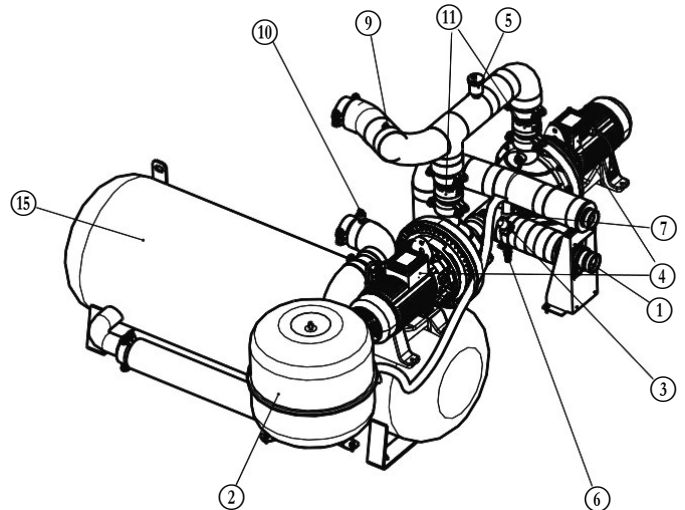

Refer to the diagram in the "Hydraulic connections" section for all references points mentioned in this chapter.

The water circulation pumps for the units in the range have been sized to allow the hydraulic modules to operate in all possible configurations based on the operating conditions specific to the system, i.e. at a range of temperature differences between the water inlet and outlet (Delta T) at full load which may vary from 3 to 10 K.

This temperature difference required between the water inlet and outlet determines the nominal flow rate of the system. Use the specification provided when selecting the unit to determine the system's operating conditions.

In particular, collect the data to be used for the control of the system flow rate:

- Units without hydraulic module: The rated unit pressure drop. This is measured with pressure gauges that must be installed at the inlet and outlet of the unit (item 21).
- Units with fixed speed pumps: Nominal flow rate. The pressure of the fluid is measured by sensors installed at the inlet of the pump and outlet of the unit (items 7 and 10). The controllers then calculate the flow rate associated with this pressure difference and display the result on the user interface. (refer to the unit control manual).
- Units with variable speed pumps: Regulation of the constant pressure differential based on readings at the hydraulic module inlet and outlet. The water buffer tank module option is not taken into account.
- Units with variable speed pumps: Regulation of the temperature difference measured at the heat exchanger inlet and outlet.

8 - WATER CONNECTIONS

If this information is not available when the system is commissioned, contact the engineering and design department responsible for the system to obtain it.

This data can be obtained either from the performance tables included in the technical documentation (for cases where the evaporator temperature delta is 5 K) or from the "Electronic Catalogue" selection program for all other applicable temperature delta in the range of 3 to 10 K.

8.3 - Units without hydraulic module

8.3.1 - General information

The nominal flow of the unit will be set using a manual valve that should be installed on the outlet of the unit (item 19 on the schematic hydraulic circuit). Changing the pressure drop of the valve allows adjustment of the system flow rate to achieve the design flow rate.

As the exact total system pressure drop is not known upon commissioning, it is necessary to adjust the water flow rate with the control valve to obtain the installation's specific flow rate.

8.3.2 - Hydraulic circuit cleaning procedure

- Open the valve completely (item 22).
- Start up the system pump.
- Read the pressure drop of the plate heat exchanger using the pressure differential gauge to find the difference between the unit inlet and outlet (item 21).
- Let the pump run for 2 hours continuously to flush the system's hydraulic circuit (presence of contaminating solids).
- Perform another reading.
- Compare this value to the initial value. A decrease in the pressure drop value indicates that the filters in the system need to be removed and cleaned. In this case, close the Shut-off valves on the water inlet and outlet (item 19) and remove then clean the filters (items 20 and 1) after draining the hydraulic part of the unit (item 6).
- Remove the air from the circuit (items 5 and 17).
- Repeat until all fouling is removed from the filter.

8.3.3 - Procedure for controlling the water flow

Once the circuit has been decontaminated, read the pressures on the pressure gauges (water inlet pressure - outlet pressure) to determine the pressure drop across the unit terminals (plate heat exchanger + internal pipework).

Compare the value obtained with the theoretical selection value.

If the pressure drop reading is above the specified value, this indicates that the flow rate at the terminals of the unit (and hence in the system) is too high. In this case, close the control valve and read the new difference in pressure. Repeat as necessary until a specific pressure drop corresponding to the unit's nominal flow rate at the operation point is achieved.

NOTE: If the network has an excessive pressure drop in relation to the available static pressure delivered by the system pump, the nominal water flow rate cannot be obtained (resulting flow rate is lower) and the difference in temperature between the water inlet and outlet of the evaporator will be increased.

To reduce the installation's hydraulic system pressure drop:

- Reduce the pressure drops of individual components (bends, level changes, valves etc.) as much as possible
- Use the correct pipe diameter;
- Avoid extending the hydraulic systems when possible.

Example: Unit with specific nominal flow 3.7 l/s

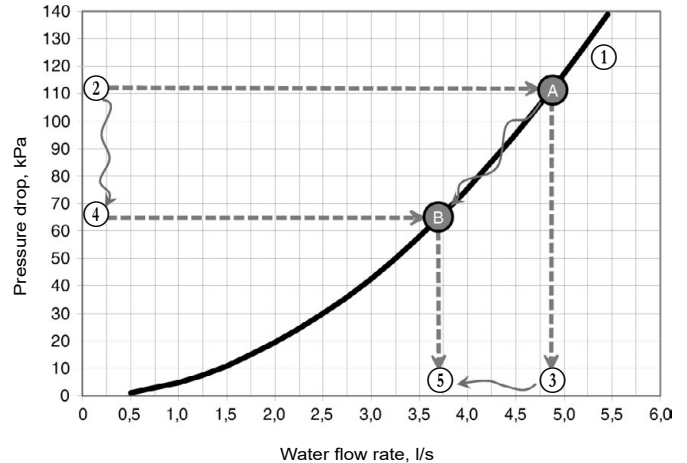

Key

- ① "Unit pressure drop (including internal water circuits)/flow rate" curve
- ② With the valve open the pressure drop read (111 kPa) gives point **A** on the curve. Operating point **A** reached with the valve open.
- ③ With the valve open, the flow rate achieved is 4.8 l/s: This is too high, and the valve must be closed again.
- ④ If the valve is partially closed, the pressure drop read (65 kPa) gives point **B** on the curve. Operating point **B** reached with the valve partially closed.
- ⑤ With the valve partially closed, the flow rate achieved is 3.7 l/s: This is the required flow rate and the valve is in the correct position.

8.4 - Units with hydraulic module and fixed-speed pump (for brine application only)

8.4.1 - General information

See chapter "Units without hydraulic module".

8.4.2 - Hydraulic circuit cleaning procedure

- Open all valves completely (item 19).
- Start up the system pump.
- Let the pump run for 2 hours continuously to flush the system's hydraulic circuit (presence of contaminating solids).
- Perform another reading.
- Compare this value to the initial value.
- A reducing value of the flow indicates that the filters on the system need to be removed and cleaned. In this case, close the Shut-off valves on the water inlet and outlet (item 19) and remove the filters (items 20 and 1) after draining the hydraulic part of the unit (item 6).
- Remove the air from the circuit (items 5 and 14).
- Repeat until all fouling is removed from the filter.

8 - WATER CONNECTIONS

8.4.3 - Water flow rate adjustment procedure

Once the circuit is cleaned, read the flow value on the user interface and compare it with design value for the system. If the value of the flow is greater than the specified value, this indicates that the overall pressure drop in the system is too low against the available static pressure generated by the pump.

In this case, close the control valve and read the new flow rate value. Repeat as necessary until a specific pressure drop corresponding to the unit's nominal flow rate at the operation point is achieved.

NOTE: If the network has an excessive pressure drop in relation to the available static pressure delivered by the unit pump, the nominal water flow cannot be obtained (lower resulting flow) and the difference in temperature between the water inlet and outlet of the evaporator will be increased.

To reduce the installation's hydraulic system pressure drop:

- Reduce the pressure drops of individual components (bends, level changes, valves etc.) as much as possible
- Use the correct pipe diameter;
- Avoid extending the hydraulic systems when possible.

8.5 - Units with hydraulic module and variable-speed pump - pressure differential control

The system flow rate has not been set to a rated value. The flow rate will be adjusted, by varying the pump speed, to maintain a constant operating pressure differential value defined by the user. The pressure sensor at the unit outlet (item 10 in the typical hydraulic circuit diagram) is used as the means of control.

The system calculates the measured pressure differential value, compares it with the setpoint value selected by the user and modulates the pump speed accordingly. The result is:

- An increased flow rate, if a lower value than the setpoint is measured,
- An decreased flow rate, if a higher value than the setpoint is measured.

This flow rate variation is realised, observing the minimum and maximum admissible unit flow rates as well as the minimum and maximum pump supply frequency values.

The pressure differential value maintained can in certain cases be different from the set point value:

- If the set point value is too high (achieved for a higher flow rate than the maximum value or a higher frequency than the maximum value), the system settles at the maximum flow rate or maximum frequency and this results in a lower pressure differential than the set point.
- If the set point value is too low (achieved for a lower flow rate than the minimum value or a lower frequency than the minimum value), the system settles at the minimum flow rate or minimum frequency and this results in a higher pressure differential than the set point.

Contact Carrier Service to discuss the implementation of the procedures set out below.

8.5.1 - Hydraulic circuit cleaning procedure

Before proceeding, it is advisable to remove any possible contamination from the hydraulic circuit.

- Start up the unit pump using the override command.
- Set the frequency to the maximum value to generate a high flow rate.
- If there is a "Maximum flow exceeded" alarm, reduce the frequency until an acceptable value is reached.
- Read the value of the flow on the user interface.
- Let the pump run for 2 hours continuously to flush the system's hydraulic circuit (presence of contaminating solids).
- Perform another reading of the flow and compare this value with the initial value. A reducing value of the flow indicates that the filters on the system need to be removed and cleaned. In this case, close the shut-off valves on the water inlet and outlet (item 19) and remove the filters (items 12 and 1) after draining the hydraulic part of the unit (item 6).
- Remove the air from the circuit (items 5 and 14).
- Repeat until all fouling is removed from the filter.

8.5.2 - Procedure for controlling the pressure differential

Setpoint

Once the circuit is cleaned, place the hydraulic circuit in the configuration for which the unit selection was performed generally (all valves open and all cooling coils active). Read the value of the flow on the user interface and compare it with the theoretical value of the range:

- If the value of the flow is greater than the specified value, reduce the pressure differential setpoint on the user interface to reduce the value of the flow.
- If the value of the flow is lower to the specified value, increase the pressure differential setpoint on the user interface to increase the value of the flow.

Repeat until the design pressure drop / flow rate is achieved.

Stop the forced operation of the pump and proceed to the configuration of the unit for the required control mode.

Modify the control parameters:

- Set water flow control to 'pressure differential'
- Set the value of the required differential pressure

By default, the unit is factory configured at the minimum speed (frequency: 50 Hz).

NOTES:

If during controlling, the low or high frequency limits are reached before reaching the specified flow, keep the pressure differential value to its lower or higher limit to enter in the control parameters.

If the user already knows the pressure differential value to be maintained at the unit outlet, this may be entered directly as a parameter. However, the hydraulic circuit cleaning sequence must not be omitted.

The option 49 Discharge Super heater BPHE is not included in the option 41 or 42/42B scope.

8 - WATER CONNECTIONS

8.6 - Units with hydraulic module and variable-speed pump - temperature difference control

The temperature sensors at the heat exchanger inlet and outlet (items 8 and 9 in the typical hydraulic circuit diagram) are used as means of control.

The system reads the measured temperature values, calculates the corresponding temperature difference, compares it with the user-selected setpoint value and modulates the pump speed as necessary:

- If a higher Delta T value than the setpoint is measured, the flow rate is increased;
- If a lower Delta T value than the setpoint is measured, the flow rate is decreased.

This flow rate variation is realised, observing the minimum and maximum admissible unit flow rates as well as the minimum and maximum pump supply frequency values.

The Delta T value maintained can in certain cases be different from the set point value:

- If the set point value is too high (achieved for a lower flow rate than the minimum value or a lower frequency than the minimum value), the system settles at the minimum flow rate or minimum frequency and this results in a lower Delta T value than the set point.
- If the set point value is too low (achieved for a higher flow rate than the maximum value or a higher frequency than the maximum value), the system settles at the maximum flow rate or maximum frequency and this results in a higher Delta T value than the set point.

Contact Carrier Service to discuss the implementation of the procedures set out below.

8.6.1 - Hydraulic circuit cleaning procedure

Refer to the procedure for cleaning the hydraulic circuit from chapter 8.3.1

8.6.2 - Procedure for adjusting the Delta T setpoint

Once the circuit is cleaned, stop the forced start of the pump and proceed to the configuration of the unit for the required control mode.

Modify the control parameters:

- Water flow rate control method (temperature differential)
- Set the value of the required differential temperature.

By default, the unit is factory configured at the minimum speed (frequency: 50 Hz).

Combination of options for the periods when the unit is in standby mode.

Ambient unit temperature range	Product		
	Without option 116	With option 116	With option 307
> 0°C to 51°C	-	-	-
-20°C to 0°C	Option 41 or Suitable antifreeze solution (such as glycol)	Option 42 ⁽¹⁾ or Suitable antifreeze solution (such as glycol) ⁽¹⁾	Option 42B ⁽¹⁾ or Suitable antifreeze solution (such as glycol) ⁽¹⁾

(1) Allow the pumps to circulate. If there is a valve, install a bypass (see diagram for winter position).

If the system is isolated by a valve, it is imperative to install a bypass as indicated below.

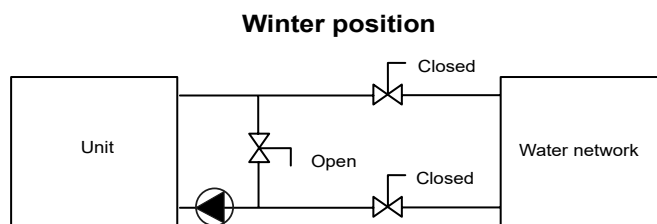

IMPORTANT REMINDERS:

Depending on the atmospheric conditions in your region, you need to:

- Add an appropriate antifreeze solution agreed by the manufacturer (maximum of 45%) to protect the system down to a temperature of 10 K below the lowest temperature likely to occur locally.
- For extended shut-downs, drain and add an anti-freeze solution to the heat exchanger (use the drain valve located at the water inlet).
- To prevent corrosion due to differential aeration, if the system is to be empty for more than 1 month, the heat transfer fluid circuit should be protected with a blanket of neutral gas (0.5 bar maximum). If the heat transfer fluid does not meet the manufacturer's recommendations, a nitrogen blanket must be applied immediately.
- In case of prolonged non-usage, the hydraulic circuits must be protected by circulating a passivating solution (consult a specialist).
- At the start of the next season, refill the unit with water and add an inhibitor.
- If auxiliary equipment is installed in the system, the installer must ensure that the resultant flow rates are still within the minimum and maximum values indicated in the operating limits table (application data). If frost protection is dependent on electric heaters, never de-energize the unit when frost protection is required. To ensure protection, the main unit disconnect switch and the auxiliary heater protection circuit breaker must be closed (see wiring diagram to locate these components). If it is not to be used in freezing conditions, or during a prolonged power failure (planned or unplanned), the water type heat exchanger and external pipes must be drained without delay. Damage caused by frost is not covered by the warranty.
- The heat exchanger temperature sensors are an essential frost protection element: If piping trace heaters are used, ensure the external heaters do not affect the measurements provided by these sensors.
- If there is a Water Type Heat Exchanger Connection sleeves option, it is necessary to install a heater on each extension in order to protect the water pipes down to an outdoor temperature of 0°C. The anti-freeze and heater solutions can be combined.

9 - NOMINAL SYSTEM WATER FLOW RATE CONTROL

9.1 - Available static pressure for the installation

Units with hydraulic module (fixed-speed pump or variable-speed pump at 50 Hz)

Data applicable for:

- Pure water at 20°C.
- Refer to the "Water exchanger water flow" section for the maximum water flow values.
- If ethylene glycol is used, the maximum flow rate is reduced.

9.1.1 - Units 040R-160R

High pressure pumps

Single pumps

Sizes 040R - 080R

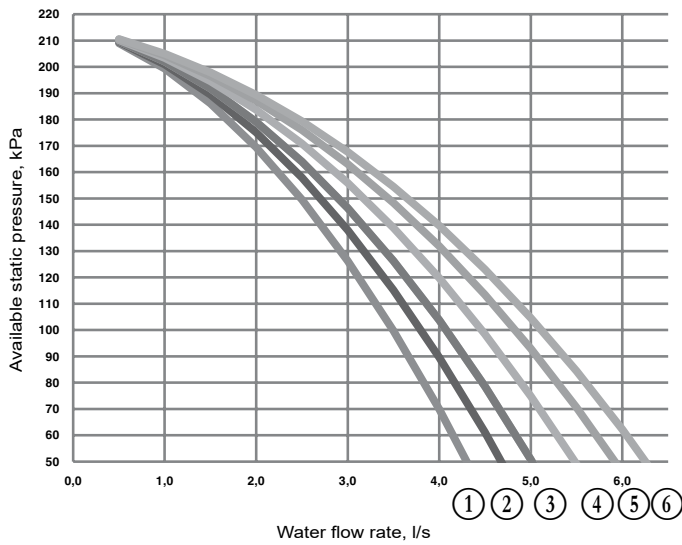

- | | |
|------------------------|------------------|
| ① 30RB/RQ - 040R | ④ 30RB/RQ - 060R |
| ② 30RB/RQ - 045R | ⑤ 30RB/RQ - 070R |
| ③ 30RB/RQ - 050R - 55R | ⑥ 30RB/RQ - 080R |

Low-pressure pumps

Single pumps

Sizes 040R-080R

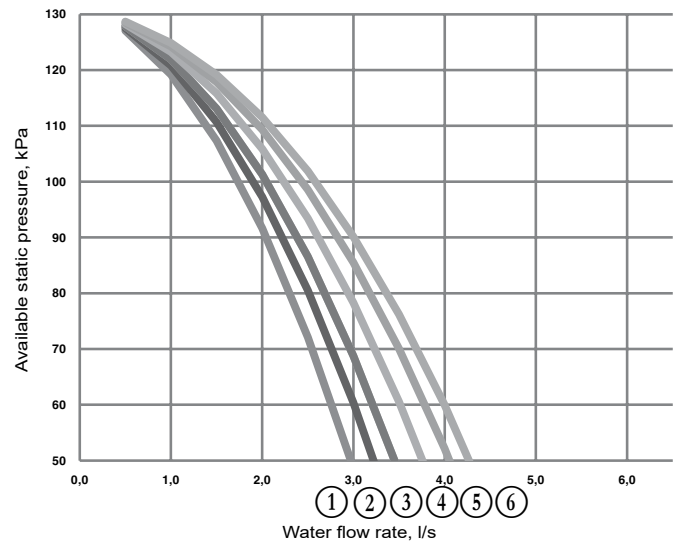

- | | |
|------------------------|------------------|
| ① 30RB/RQ - 040R | ④ 30RB/RQ - 060R |
| ② 30RB/RQ - 045R | ⑤ 30RB/RQ - 070R |
| ③ 30RB/RQ - 050R - 55R | ⑥ 30RB/RQ - 080R |

Sizes 090R-160R

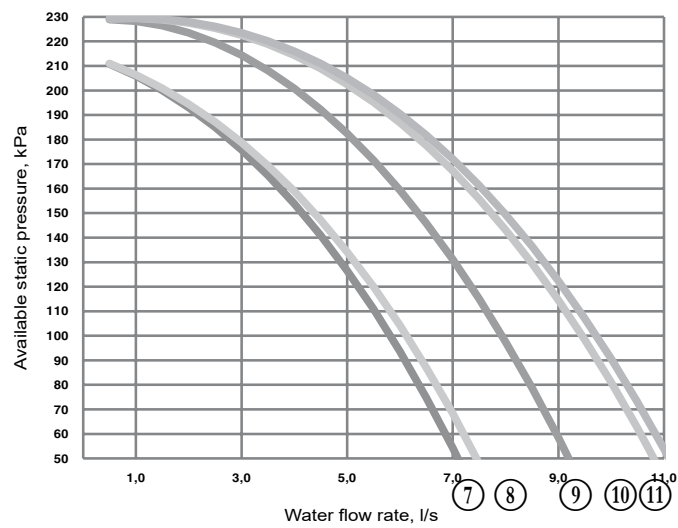

- | | |
|------------------|------------------|
| ⑦ 30RB/RQ - 090R | ⑩ 30RB/RQ - 140R |
| ⑧ 30RB/RQ - 100R | ⑪ 30RB/RQ - 160R |
| ⑨ 30RB/RQ - 120R | |

Sizes 090R-160R

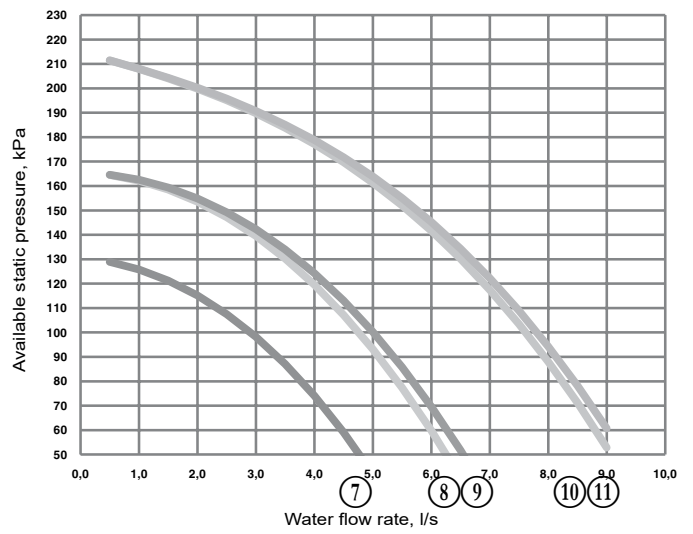

- | | |
|------------------|------------------|
| ⑦ 30RB/RQ - 090R | ⑩ 30RB/RQ - 140R |
| ⑧ 30RB/RQ - 100R | ⑪ 30RB/RQ - 160R |
| ⑨ 30RB/RQ - 120R | |

10 - SYSTEM START-UP

10.1 - Checks before system start-up

Before starting up the thermodynamic system, the complete system, including the thermodynamic system, must be verified against the installation drawings, dimensional drawings, system piping and instrumentation diagrams and the wiring diagrams.

All measures must be taken to ensure that the pressure and temperature limits, specifically those listed on the unit nameplates, are not exceeded during operation, maintenance and recycling.

Heat exchange fluid temperatures above the maximum recommended can lead to an increase in the refrigerant pressure and can cause a loss of refrigerant due to the relief valve discharge.

National regulations must be followed during these checks. If the national regulation does not specify any details, refer to standard EN 378 as follows:

External visual installation checks:

- Ensure that the machine is charged with refrigerant. Verify on the unit name plate that the 'fluid transported' is that recommended for operation, and is not nitrogen.
- Compare the complete installation with the refrigeration system and power circuit diagrams.
- Check that all documents provided by the manufacturer (dimensional drawings, pipe and instrument diagram (PID), declarations, etc.) to comply with the regulations are present. If any documentation is missing, order a replacement.
- Make sure the environmental safety and protection devices and arrangements provided by the manufacturer to comply with the regulations are in place.
- Make sure all declarations of conformity for the pressure containers, identification plates and documentation required to comply with local regulations are present.
- Verify the free passage of access and safety routes.
- Comply with the instructions and directives to prevent the deliberate release of refrigerant fluids.
- Verify the installation of connections.
- Verify the supports and fixing elements (materials, routing and connection).
- Verify the quality of welds and other joints.
- Check the protection against mechanical damage.
- Check the protection against heat.
- Check the protection of moving parts.
- Verify the accessibility for maintenance or repair and to check the piping.
- Verify the status of the valves.
- Verify the quality of the thermal insulation.
- Check the condition of 400 V cable insulation.

10.2 - Commissioning

Always ensure you have read and fully understood the operating instructions for the units before starting up the unit, and ensure the following precautions have been taken:

- Check the heat-transfer fluid circulation pumps, the air handling equipment, and any other equipment connected to the heat exchangers.
- Refer to the manufacturer's instructions.
- Refer to the electrical diagram delivered with the unit.
- Ensure there are no refrigerant leaks. Check the tightening of the fastening clips on all the pipes.
- Check the power supply at the main connection point and the order of phases.
- For units without the factory-fitted hydraulic module option, the installer is responsible for heat protection and the connections relating to the system pump.
- Check that the compressor crankcase heaters, and the compressor head heaters if applicable, have been energised for 6 hours before starting up the system.
- Open the suction shut-off valves on each circuit for the corresponding units.

IMPORTANT:

Commissioning and start-up must be supervised by a qualified engineer.

- ***The system must have a heat load and water flowing in the exchangers when it is started up and tested.***
- ***All setpoint adjustments and control tests must be carried out before the unit is started up.***
- ***Refer to the Service guide.***

Proceed with the unit commissioning.

Make sure all safety devices are operational, and especially that the high pressure switches are engaged and that any alarms have been cleared.

NOTE:

If the manufacturer's recommendations (system, water and power connections) are not observed, no claims made under the warranty will be accepted.

10 - SYSTEM START-UP

10.3 - Essential points to check

Compressors

Ensure that each compressor is rotating in the correct direction, checking that the discharge temperature rises quickly, the high pressure increases and the low pressure drops. If it is rotating in the wrong direction, the electric power supply is incorrectly wired (reversed phases). To ensure rotation in the correct direction, swap two power supply phases.

- Check the compressor discharge temperature using a contact sensor
- Check the input current; it should be normal
- Check all safety devices to make sure they operate correctly

Hydraulics

As the exact total system pressure drop is not known at start-up, adjust the water flow rate with the control valve until the desired nominal rate is obtained.

Please refer to the chapter "Nominal system water flow rate control - Procedure for adjusting the flow rate" for the steps to follow.

In any case, the hydraulic circuit must be free from pollution (removal of any solid particles in the circuit) before start-up: Please refer to the chapter "Nominal system water flow rate control - Procedure for cleaning the hydraulic circuit" for the steps to follow.

Refrigerant charge

Each unit is shipped with an exact charge of refrigerant and oil.

Check that there are no visible refrigerant or oil leaks:

- No apparent damage on the refrigerant circuit pipes (no trauma, cracks, deformation)
- No traces of grease on the connections and refrigerant circuit sensors

In case of doubt, use a refrigerant leak detection device suited to the fluid in the unit.

11 - MAIN COMPONENTS OF THE UNIT AND OPERATING CHARACTERISTICS

11.1 - Compressors

The units use hermetically sealed scroll compressors.

Each compressor sub-function is equipped with:

- Anti-vibration mountings between the unit chassis and the chassis of the compressor sub-assembly,
- A safety pressure switch on the discharge line of each circuit,
- Pressure and temperature sensors at the common suction line and a pressure sensor at the common discharge line.
- Restrictors (not visible) fitted on certain suction pipes to ensure the oil level is equalised between each compressor.

11.2 - Lubricant

The compressors installed on the units have an oil charge, ensuring good lubrication under all operating conditions.

The oil level check can be done:

- On the system: The oil levels must be greater than or equal to half of the sight glass.
- A few minutes after the sub-function has come to a complete stop: The oil levels must be visible in the sight glasses.

If this is not the case, there might be a leak or an oil trap in the circuit.

If there is an oil leak, find and repair it, then refill with refrigerant and oil.

See the Service Guide for the oil removal and refill procedures.

IMPORTANT: *Too much oil in the circuit can cause the unit to malfunction.*

NOTE :

Only use oils which have been approved for the compressors.

Never use oils which have been exposed to air.

IMPORTANT: *Polyolester oils are completely incompatible with mineral oils.*

Only use the oils specified by the manufacturer.

11.3 - Air-cooled exchanger

30RB units are equipped with all-aluminium micro-channel coils (MCHE).

30RQ units are equipped with round tube plate fin coils (RTPF).

11 - MAIN COMPONENTS OF THE UNIT AND OPERATING CHARACTERISTICS

11.4 - Fans

Each fan motor assembly is equipped with a high-performance impeller made from recyclable composite material.

The motors are three-phase, with lifetime lubricated bearings and class F insulation (IP55 level).

When option 12 is not selected, the pressure available at the fan outlet is zero.

According to regulation No. 327/2011 implementing directive 2009/125/EC with regard to eco-design requirements for fans driven by motors with an electric input power between 125 W and 500 kW.

Product	30RB/RQ Standard (1)	30RB/RQ Standard(2)	30RB/RQ option 6B, 12, 15LS, 16, 28	30RB/RQ Option 17
Overall efficiency %	37,1	38,6	40,2	48,2
Measurement category	A	A	A	A
Efficiency category	Static	Static	Static	Static
Target efficiency level ERP2015	N(2015) 40	N(2015) 40	N(2015) 40	N(2015) 40
Efficiency level at the optimum efficiency point	43,8	42,9	43,4	53,2
Speed regulator	No	No	Yes	Yes
Year of manufacture	See label on the unit	See label on the unit	See label on the unit	See label on the unit
Fan manufacturer	Simonin	Simonin	Simonin	Simonin
Motor manufacturer	Leroy Somer	Leroy Somer	Leroy Somer	EBM
Fan PN	00PSG000000100	00PSG000000100	00PSG000000100	00PSG000000100
Motor PN	00PPG000464500	00PPG000464600	00PPG000464700	00PSG003716100
Nominal motor capacity kW	0,9	2,25	3	1,64
Flow rate m ³ /s	3,59	4,07	5,11	4,24
Pressure at optimum energy efficiency Pa	90	195	248	174,6
Nominal Speed rpm	710	966	1137	960
Specific ratio	1,002	1,002	1,002	1,002
Relevant information to facilitate the disassembly, recycling or removal of the product at the end of life	See the Maintenance manual	See the Maintenance manual	See the Maintenance manual	See the Maintenance manual
Relevant information to minimise impact on the environment	See the Maintenance manual	See the Maintenance manual	See the Maintenance manual	See the Maintenance manual

Regulation (EU) 2019/1781 repealing regulation 640/2009 governs the requirements relating to ecodesign applicable to electric motors and to speed regulators in accordance with directive 2009/125/EC.

Product	30RB/RQ Standard (1)	30RB/RQ Standard (2)	30RB/RQ option 6B, 12, 15LS, 16, 28	30RB/RQ Option 17
Motor type	Two-speed asynchronous	Two-speed asynchronous	Asynchronous	Synchronous
Number of poles	8	6	6	-
Rated input frequency Hz	50	50	60	50
Nominal voltage V	400	400	400	400
Number of phases	3	3	3	3
Motor included in the application domain of regulation (EU) 2019/1781 and amendment 4/2014	No	No	No	NO
Justification for exemption	Article 2(2)(l)	Article 2(2)(l)	Article 2(2)(l)	Article 2(2)(b)
Ambient air temperature for which the motor is specifically designed °C	70	70	70	70

(1) For sizes 30RB/RQ 040R - 055R only

(2) For sizes 30RB/RQ 060R - 160R only

The data above for the fans and motors are compulsory as part of the ecodesign regulations, and are provided for a self-contained component (not included in the cooling system).

11 - MAIN COMPONENTS OF THE UNIT AND OPERATING CHARACTERISTICS

11.5 - Electronic expansion valve (EXV)

The EXV has a stepper motor and a sight glass which can be used to check the mechanism movement and the presence of the liquid gasket.

11.6 - Moisture indicator

This is used to check the unit charge and the presence of moisture in the circuit.

The presence of bubbles in the sight-glass indicates an insufficient charge or non-condensables in the system.

The presence of moisture changes the colour of the indicator paper in the sight-glass (from green to yellow).

11.7 - Filter drier

The role of the filter drier is to keep the circuit clean and moisture free.

The moisture indicator shows when the filter drier needs to be changed.

A difference in temperature between the filter inlet and outlet shows that the element is dirty.

11.8 - Water type heat exchanger

The exchanger is a brazed plate heat exchanger with two refrigerant circuits.

The hydraulic connections of the heat exchanger are Victaulic connections.

The water heat exchanger is thermally insulated with 19 mm of foam rubber.

As an option it can be protected against frost by an electric heater (water exchanger frost protection option).

Any products used for thermal insulation of recipients during hydraulic connection must be chemically neutral to the surfaces on which they are applied. All original materials supplied by the manufacturer comply with this requirement.

NOTE - Monitoring during operation

- Follow local regulations on the monitoring of pressure equipment
- The user or operator is usually requested to create and maintain a monitoring and maintenance log.
- In the absence of any regulations, or in addition to the regulations, follow the guidance in the EN 378 standard.
- Follow the local professional recommendations, whenever they exist.
- Regularly check for the presence of any impurities (e.g. sand, grit) in the heat-transfer fluids. These impurities can cause wear and/or pitting corrosion.
- The reports of the periodical checks by the user or the operator must be included in the monitoring and maintenance log.

11.9 - Refrigerant

Units operating with R32 (A2L fluid).

Potentially flammable zones have been identified on the edge of the unit: Please refer to chapter "4.6 - Positioning of Potentially flammable zones around the unit".

Please comply with applicable recommendations in the Potentially flammable zones.

11.10 - High-pressure safety pressostat

The units are equipped with high-pressure safety pressostats with automatic reset.

These pressure switches are located at the discharge of each circuit.

11.11 - SmartVu™ control



The interface for the SmartVu™ control has the following characteristics:

- It has a 4.3-inch colour screen.
- It is intuitive and user-friendly. Clear and concise information is presented in the local language (choice of 8 languages).
- The complete menu can be adapted to the various users (end customer, maintenance personnel, manufacturer engineers).
- Unit setting and use are secure. Password protection prevents unauthorised access to advanced parameters.
- No password is required to access the most important operating parameters.

12 - OPTIONS

12.1 - Tables of options

Options	No.	Description	Advantages	30RB (R32)	30RQ (R32)
Corrosion protection, traditional coils	3A	Fins made of pre-treated aluminum by chemical conversion.	Improved corrosion resistance, recommended for moderate marine and urban environments	-	040-160
Low-temperature brine solution	6B	Low temperature chilled water production down to -8°C with ethylene glycol and propylene glycol.	Covers specific applications such as ice storage and industrial processes	040-160	040-160
High-pressure static fans	12	Unit equipped with high-pressure static variable-speed fans (maximum 200 Pa), each fan being equipped with a connection flange for connection to the ducting system.	Ducted fan discharge, optimised temperature control, based on the operating conditions and system characteristics	040-160	040-160
Return air connection frame	12A	Unit equipped with a connection frame at the heat exchange coil inlet	Facilitates channelling of the air at the unit inlet.	040-080	040-080
Very low noise level	15LS	Acoustic compressor enclosure and low-speed fans	Noise level reduction for sensitive sites	040-160	040-160
High ambient temperature	16	Unit equipped with a higher speed fan	Unit operating range extended to higher ambient temperatures	040-160	040-160
EC fans	17	Unit equipped with EC fans	Improves the unit's energy efficiency	040-160	040-160
Protection grilles	23	Metallic protection grilles	Coil protection against possible impact	040-160	040-160
Air filter and return air connection frame	23B	Unit equipped with a connection frame at the heat exchange coil inlet and G2 efficiency washable filter in accordance with EN 779	Facilitates channelling of the air at the unit inlet and protects the air exchanger against pollution	040-080	040-080
Soft starter per compressor	25	Electronic starter on each compressor	Reduced start-up current	040-160	040-160
Winter operation down to -20°C	28	Fan speed control via frequency converter	Stable unit operation when the outdoor air temperature is between -10°C and -20°C	040-160	040-160
Water exchanger frost protection	41	Electric heater on the water type heat exchanger and the water duct	Water type heat exchanger module frost protection for an outdoor air temperature between 0°C and -20°C	040-160	040-160
Hydronic module antifreeze protection	42	Electric heater on the hydronic module	Antifreeze protection of the hydronic module for outdoor temperatures down to -20°C	040-160	040-160
Exchanger and hydronic module antifreeze protection	42B	Electric heaters on the water heat exchanger, water pipes, hydronic module, optional expansion tank and buffer tank	Water type heat exchanger and hydronic module frost protection down to an outdoor air temperature of -20°C	040-160	040-160
Partial heat recovery	49	Unit equipped with one desuperheater on each refrigerant circuit	Simultaneous production of free high-temperature hot water and chilled water production (or hot water for the heat pump)	040-160	040-160
Lead/Lag operation	58	Unit equipped with supplementary water outlet temperature sensor kit (to be field installed) allowing Lead/Lag operation of two units connected in parallel	Optimised operation of two units connected in parallel operation with runtime balancing	040-160	040-160
Evaporator single HP pump	116R	High-pressure fixed-speed water pump, drain valve, air vent and pressure sensors. (optional expansion vessel and built-in safety hydraulic components available)	Quick and easy installation (plug & play)	040-160	040-160
Evaporator dual HP pump	116S	Dual high pressure fixed-speed water pump, pressure sensors. (optional expansion tank and built-in hydraulic safety components available)	Quick and easy installation (plug & play)	040-160	040-160
Variable-speed single HP pump	116V	Single low pressure water pump, water filter, electronic water flow control, pressure sensors. Multiple variable water flow control options. (optional expansion vessel and built-in hydraulic safety components available)	Quick and easy installation (plug & play), significant pumping energy cost savings (up to 2/3), tighter water flow control.	040-160	040-160
Variable-speed dual high-pressure pump	116W	Dual high-pressure water pump with speed regulator, pressure sensors. Multiple water flow rate control options. For more details, refer to the dedicated chapter.	Quick and easy installation (plug & play), significant pumping energy cost savings (more than two-thirds), tighter water flow control, improved system reliability	040-160	040-160
Variable-speed single LP pump	116X	Single low pressure water pump with speed regulator, pressure sensors. Multiple water flow rate control options. (optional expansion vessel and built-in hydraulic safety components available)	Quick and easy installation (plug & play), significant pumping energy cost savings (up to 2/3), tighter water flow control.	040-160	040-160

12 - OPTIONS

Options	No.	Description	Advantages	30RB (R32)	30RQ (R32)
Variable-speed dual LP pump	116Y	Evaporator hydronic module equipped with a variable-speed low-pressure pump, a drain valve, an air vent and pressure sensors. For more details, refer to the dedicated chapter (expansion tank not included; option with built-in hydraulic safety components available)	Quick and easy installation (plug & play), significant pumping energy cost savings (more than two-thirds), tighter water flow control, improved system reliability	040-160	040-160
Evaporator single LP pump	116T	Single low-pressure fixed-speed water pump, pressure sensors. (optional expansion vessel and built-in hydraulic safety components available)	Quick and easy installation (plug & play)	040-160	040-160
LP dual-pump hydronic module	116U	Dual low-pressure water pump, water filter, pressure sensors. For more details, refer to the dedicated chapter (expansion tank not included; option with built-in hydraulic safety components)	Quick and easy installation (plug & play)	040-160	040-160
Heating Optimized	119D	Specific configuration to optimized heating mode	Enlarge operating map in heating mode, and increase energetics performances (COP/SCOP)	040-160	040-160
Lon gateway	148D	Two-directional communication board complying with Lon Talk protocol	Connects the unit by communication bus to a building management system	040-160	040-160
Bacnet over IP	149	Two-directional high-speed communication using BACnet protocol over Ethernet network (IP)	Easy and high-speed connection by Ethernet line to a BMS. Allows access to multiple unit parameters	040-160	040-160
ModBus over IP and RS485 communication gateway	149B	Two-directional high-speed communication using the ModBus over Ethernet network (IP) protocol	Easy, quick connection via Ethernet line to a building technical management system. Allows access to several unit parameters.	040-160	040-160
External boiler management	156A	Control board factory-installed on the unit to control a boiler	Extended remote control capabilities to a boiler on/off command. Permits easy control of a basic heating system	-	040-160
Electric heaters management	156B	Control board factory-installed on the unit with additional inputs/outputs in order to manage up to 4 external heating stages (electrical heaters...)	Extended remote control capabilities to up to 4 electric heaters. Permits easy control of a basic heating system	-	040-160
Smart Grid Ready	157D	Standardized and secured label for integration on the smart electrical networks (DE, AUT, CH).	Optimizing the energy efficiency of the installation and helping to reduce the carbon footprint	-	040-160
Input contact for Refrigerant leak detection	159	0-10 V signal to report any refrigerant leakage in the unit directly on the controller (the leak detector itself must be supplied by the customer)	Immediate customer notification of refrigerant losses to the atmosphere, allowing timely corrective actions	040-160	040-160
Refrigerant leak detector	159C	Unit equipped with refrigerant leak detector	Immediate customer notification of refrigerant losses to the atmosphere, allowing timely corrective actions	040-160	040-160
Compliance with Russian regulations	199	EAC certification	Compliance with Russian regulations	040-160	040-160
Insulation of the evaporator inlet/outlet refrigerant lines	256	Thermal insulation of the evaporator inlet/outlet refrigerant lines, with flexible and UV-resistant insulation	Prevents condensation on the evaporator inlet/outlet refrigerant lines	040-160	040-160
Enviro-Shield anti-corrosion protection	262	Coating applied using a conversion process which modifies the surface of the aluminium producing a coating that is integral to the coil. Complete immersion in a bath to ensure 100% coverage. Minimal heat transfer variation, tested to withstand more than 4000 hours of salt spray as per ASTM B117 (or equivalent)	Improved corrosion resistance, recommended for use in moderately corrosive environments	040-160	-
Super Enviro-Shield anti-corrosion protection	263	Extremely durable and flexible epoxy polymer coating applied by electro coating process, final UV protective topcoat. Minimal heat transfer variation, tested to withstand 6000 hours of constant neutral salt spray as per ASTM B117 (or equivalent), improved impact resistance as per ASTM D2794 (or equivalent)	Improved corrosion resistance, recommended for use in extremely corrosive environments	040-160	-
Evaporator screw connection sleeves kit	264	Evaporator inlet/outlet screw connection sleeves	Allows unit connection to a screw connector	040-160	040-160
Evaporator sleeve kit (to be welded)	266	Victaulic piping connections with welded joints	Easy installation	040-160	040-160
Reinforced ECM filtration for fan VFD	282A	Fan variable frequency drive compliant with IEC 61800-3 class C1	Allows unit installation in domestic residential environment by reducing electromagnetic interferences	040-160	040-160

12 - OPTIONS

Options	No.	Description	Advantages	30RB (R32)	30RQ (R32)
Reinforced ECM filtration for pump VFD	282B	Pump variable frequency drive compliant with IEC 61800-3 class C1	Allows unit installation in domestic residential environment by reducing electromagnetic interferences	040-160	040-160
Expansion tank	293	6-bar expansion tank integrated in the hydraulic module (requires hydraulic module option)	Easy and fast installation (plug & play), and protection of closed water systems from excessive pressure	040-160	040-160
Water buffer tank module	307	Built-in water buffer tank module	Avoids short cycle on compressors and ensures stable water in the loop	040-160	040-160
Dry cooler management, free cooling mode	313	Control and connections to a free cooling dry cooler 09PE or 09VE fitted with option FC control box	Easy system management, control capacity extended to a dry cooler used in free cooling mode	040-160	-
Compliance with UAE regulations	318	Additional label on the unit with rated power input, rated current and EER in accordance with AHRI 550/590	Compliance with ESMA standard UAE 5010-5:2019.	040-160	-
Compliance with Qatar regulations	319	Specific name plate on the unit with 415 V +/-6% power supply	Compliance with KAHRAMAA regulations in Qatar	040-160	-
Installation or application process outside Europe	326	Specific management of option compatibility	Permits non-standard option compatibility for HVAC application in the EU	040-160	040-160
Compliance with Moroccan regulations	327	Specific regulatory documentation	Compliance with Moroccan regulations	040-160	040-160
Delivery with plastic tarp cover	331	Unit wrapped in a plastic cover and strapped onto a wooden pallet.	Protects against dust and external soiling of the unit during storage and transport.	040-160	040-160

12.2 - Description

12.2.1 - Hydraulic module without variable speed (Options 116R, 116S, 116T, 116U)

The hydraulic module is composed of the system's main hydraulic components: Factory-fitted water pump, screen filter and relief valve.

The fixed speed operating pressure pump provides the nominal flow rate for the system water loop.

Several types of water pump are available to suit all applications:

- Single or dual low pressure pumps,
- Single or dual high pressure pumps.

The nominal flow rate of the system should be adjusted using a manual control valve provided by the customer.

The relief valve placed on the water inlet pipes at the pump inlet limits the pressure to 400 kPa (4 bar).

A screen filter that can be easily removed is placed at the pump inlet and protects the pump and the plate heat exchanger against solid particles that are greater than 1.2 mm.

Additional options can be ordered if necessary:

- Option 42 (42B if option 307): Hydraulic module protection (42) or hydraulic module and buffer tank protection (42B) down to an outdoor temperature of -20°C.
- Option 293: Expansion tank for water circulation system.

IMPORTANT: The use of the hydraulic module on open systems is prohibited.

12.2.2 - Hydraulic module with variable speed (Options 116V, 116W, 116X, 116Y)

The composition of the hydraulic module with variable speed is similar to that of the hydraulic module without variable speed.

In this case, the pump is controlled by a variable frequency drive that allows the pump's nominal flow rate to be adjusted according to the chosen control mode (constant pressure or temperature differential, or fixed speed) and the system operating conditions.

IMPORTANT: The use of the hydraulic module on open systems is prohibited.

12.2.3 - Partial heat recovery (Option 49)

This option enables free hot water to be produced using heat recovery by desuperheating the compressor discharge gases. The option is available for the entire 30RB and 30RQ range.

A plate heat exchanger is installed as standard, with the air-cooled exchanger coils on the compressor discharge line of each circuit (With this design, the function is ensured for the 30RB/30RQ unit in cooling mode and in heating mode).

The control configuration for the desuperheater option is factory assembled (see chapter 12.2.3.4 - Operation). The installer must protect the heat exchanger against frost.

12 - OPTIONS

12.2.3.1 - Physical properties of units with partial heat recovery using desuperheaters

30RB		040R	045R	050R	055R	060R	070R	080R	090R	100R	120R	140R	160R
Desuperheater in circuits A/B		Brazed-plate heat exchanger											
Water volume circuits A/B	l	0,49	0,49	0,49	0,49	0,49	0,65	0,65	0,86	0,86	0,86	0,65	0,65
Maximum operating pressure, water side	kPa	1000	1000	1000	1000	1000	1000	1000	1000	1000	1000	1000	1000
Water connections		Victaulic											
Connection	in	1	1	1	1	1	1	1	1	1	1	1	1
External diameter	mm	42	42	42	42	42	42	42	42	42	42	42	42
Operating weight ⁽¹⁾													
Standard unit	kg	420	421	440	440	447	458	466	695	758	768	893	909
Unit + 116V & 49 options	kg	440	442	460	461	468	478	487	715	778	793	918	934
Unit + 116W & 49 options	kg	467	469	487	488	495	505	514	742	805	825	951	967
Unit + 116V, 307 & 49 options	kg	792	793	812	813	819	830	838	1133	1196	1211	1336	1352
Unit + 116W, 307 & 49 options	kg	819	820	839	839	846	857	865	1160	1223	1243	1369	1385

30RQ		040R	045R	050R	060R	070R	080R	090R	100R	120R	140R	160R	
Desuperheater in circuits A/B		Brazed-plate heat exchanger											
Water volume circuits A/B	l	0,49	0,49	0,49	0,49	0,65	0,65	0,86	0,86	0,86	0,65	0,65	
Maximum operating pressure, water side	kPa	1000	1000	1000	1000	1000	1000	1000	1000	1000	1000	1000	
Water connections		Victaulic											
Connection	in	1	1	1	1	1	1	1	1	1	1	1	
External diameter	mm	42	42	42	42	42	42	42	42	42	42	42	
Operating weight ⁽¹⁾													
Standard unit	kg	456	458	481	508	518	528	782	842	890	1022	1026	
Unit + 116V & 49 options	kg	476	478	501	528	539	548	802	862	915	1047	1051	
Unit + 116W & 49 options	kg	503	505	528	555	566	575	828	888	947	1080	1084	
Unit + 116V, 307 & 49 options	kg	828	830	853	880	890	900	1220	1280	1333	1465	1469	
Unit + 116W, 307 & 49 options	kg	855	857	880	907	917	927	1246	1306	1365	1498	1502	

(1) Weights are guidelines only. Refer to the unit name plate.

(2) Options: 116W = Variable-speed high-pressure dual-pump hydraulic module, 307 = Water buffer tank module,

12 - OPTIONS

30RB-040R to 080R, units with desuperheater

Position of the desuperheater inlets and outlets

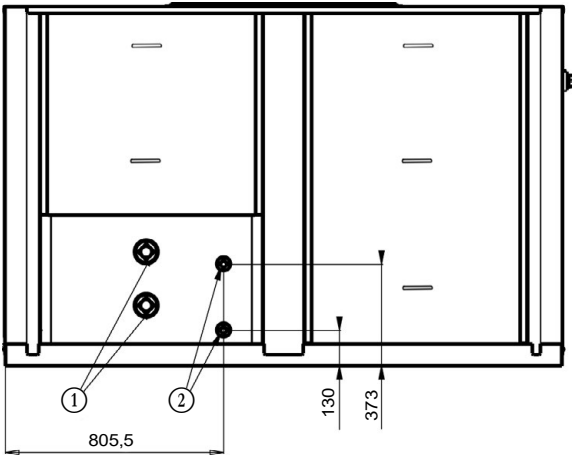

30RQ-040R to 080R, units with desuperheater

Position of the desuperheater inlets and outlets

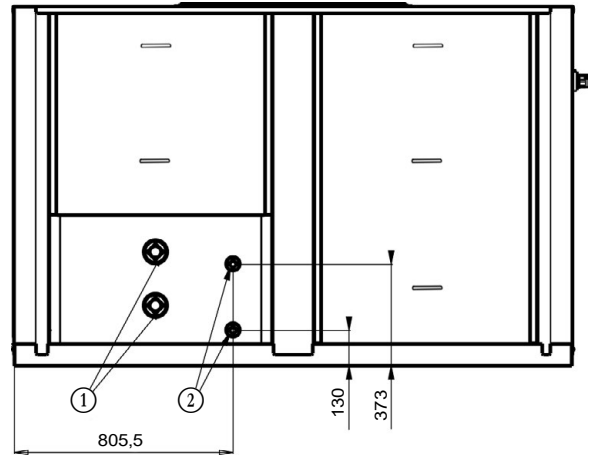

30RB-090R to 120R, units with desuperheater

Position of the desuperheater inlets and outlets

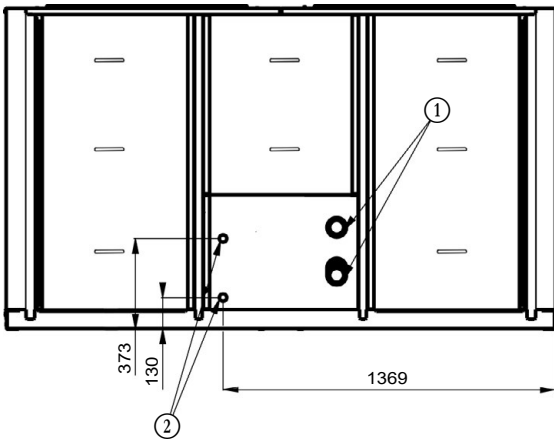

30RQ-090R to 120R units with desuperheater

Position of the desuperheater inlets and outlets

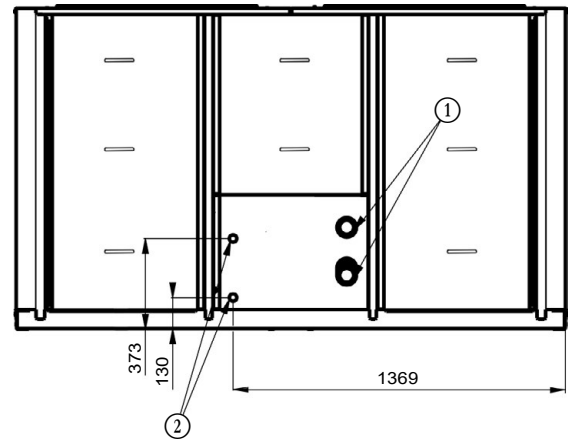

30RB-140R to 160R, units with desuperheater

Position of the desuperheater inlets and outlets

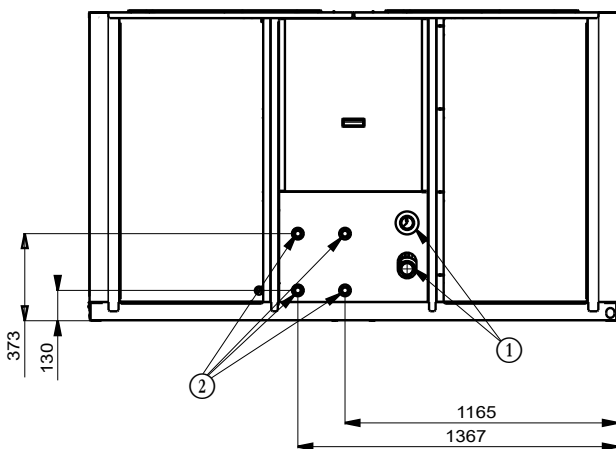

30RQ-140R to 160R units with desuperheater

Position of the desuperheater inlets and outlets

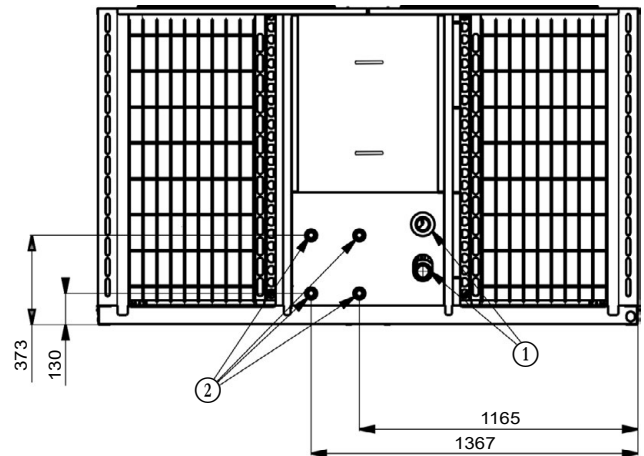

Unit with grille protection option

- ① Unit water inlet and outlet
- ② Water inlet and outlet, unit with option 49

Unit with grille protection option

- ① Unit water inlet and outlet
- ② Water inlet and outlet, unit with option 49

12 - OPTIONS

12.2.3.2 - Installation and operation of the heat recovery with desuperheater option

Units with the desuperheater option are supplied with one plate heat exchanger per refrigerant circuit.

When installing the unit, the heat recovery plate heat exchangers must be insulated and protected against frost if required.

Refer to the main diagram below for the main components or functions associated with a unit with desuperheater option in a standard system.

Typical installation diagram of units with the desuperheater option

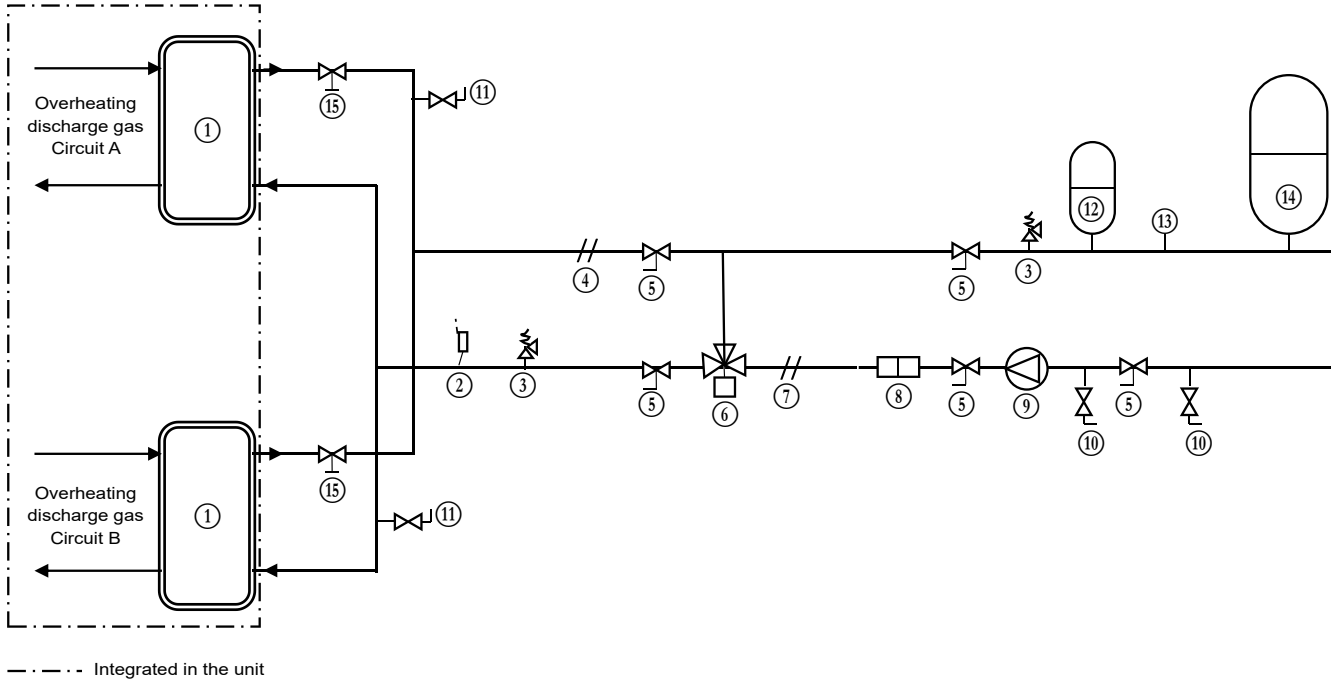

Key

Components assembled on unit

- ① Brazed plate heat exchanger (desuperheater)

Installation components (installation example)

- ② Flow rate controller
- ③ Safety relief valve
- ④ Water outlet temperature sensor (not supplied and not controlled by the unit)
- ⑤ Shut-off valve
- ⑥ Three-way valve (recommended and essential for low water inlet temperature)
- ⑦ Water inlet temperature sensor (not supplied and not controlled by the unit)
- ⑧ Filter to protect the pump and the heat recovery condenser
- ⑨ Desuperheater recovery hydraulic circuit pump
- ⑩ Water circuit bleed or charging valve
- ⑪ Air vent
- ⑫ Expansion tank
- ⑬ Pressure gauge
- ⑭ Hot water tank
- ⑮ Desuperheater water flow balancing and regulating valve

12 - OPTIONS

12.2.3.3 - Installation

The hydraulic supply for each desuperheater is delivered in parallel.

The hydraulic connection on the desuperheater water inlet and outlets must not generate any local mechanical stress on the exchangers. If necessary, install flexible couplings.

Fit water flow rate balancing and control valves at the exchanger outlet.

Balancing and control of the flow rates may be performed by reading the pressure drop in the exchangers.

The pressure drop on each of these must be identical to the total water flow rate given by the selection programme.

To adjust the balancing valves before starting up the system, refer to the pressure drop curves below.

It is possible to fine-tune the water flow rate settings for each desuperheater when the unit is running at full load by trying to obtain water outlet temperatures which are strictly identical for each of the circuits.

Option 49, BPHE is not covered by anti freeze protection (option 41; 42 and 42B).

The installer must realize the anti freeze protection (add glycol, electrical heater, insulation or add a drain plug).

12.2.3.4 - Operation

The activation and deactivation of the desuperheater mode is ensured by the DI-07 of the CIOB A board. (Terminal block n° 49/49A)

The volume of the desuperheater circuit water loop must be as low as possible to be able to rapidly increase the temperature during warm-up.

The minimum desuperheater water inlet temperature is 30°C.

This may require the use of a three-way valve (item 31), with its controller and sensor controlling the minimum required water inlet temperature.

The desuperheater water loop must include an expansion tank selected according to the volume of the water and a relief valve (Maximum 10 bars) in order to ensure that the water temperature is maintained below 100°C.

12.2.3.5 - Operating limits

30RB/30RQ units

Desuperheater		Minimum	Maximum
Entering water temperature at start-up	°C	30 ⁽¹⁾	75
Water outlet temperature during operation	°C	45	80
Water inlet temperature on shut-down	°C	3	75

Note: Do not exceed the maximum operating temperature.

(1) The water inlet temperature at start-up must not be lower than 30°C. On lower temperature installations, a 3-way valve is required until the desuperheater water outlet reaches 45°C.

Cooling mode operating range

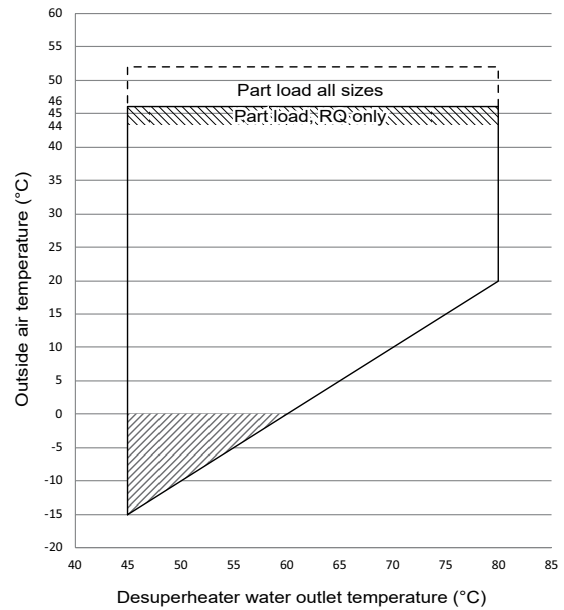

Heating mode operating range

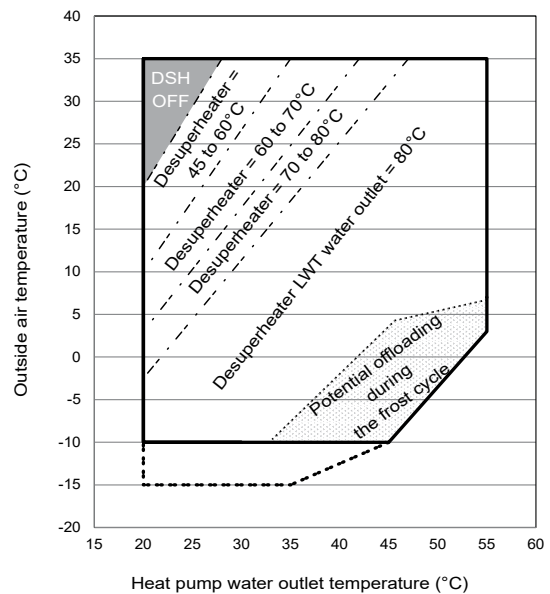

Notes

- Desuperheater water type heat exchanger $\Delta T = 10K$.
- The hydraulic and/or water type heat exchanger module must be protected against frost (option 41 or 42 or 42B) or the loop must be protected with by an antifreeze solution for outdoor temperatures $< 0^{\circ}C$. However, the customer is responsible for protecting the desuperheater water type heat exchanger water loop for outdoor temperatures under $0^{\circ}C$.
- Operating ranges are guidelines only. Verify the operating range with the electronic catalogue.

Key

- Operating range at full load
- Extension of the operating range, 30RB unit: Frost protection required (see note 2).
- Heating mode: Partial load at inlet air temperature between -10 and $-15^{\circ}C$. Cooling mode: Partial load at inlet air temperature above $46^{\circ}C$. Limited desuperheater power.
- Operating range at partial load for RQ only with limited desuperheater power.
- Potential load shedding before defrosting during frost cycle, depending on the humidity conditions. Limited desuperheater power. Please refer to the selection in the electronic catalogue.
- Desuperheater not operational
- Limited desuperheater leaving water temperature

12 - OPTIONS

12.2.4 - Operation of two units as a Lead/Lag pair (option 58)

The customer must connect both units with a communication bus in 0.75 mm² twisted, shielded cable (contact the manufacturer's Service for the installation).

All parameters required for Lead/Lag operation must be configured by the Service configuration menu.

All remote controls of the Lead/Lag assembly (start/stop, setpoint, load shedding, etc.) are managed by the unit configured as the lead and must only be applied to the lead unit.

Units supplied with hydraulic module

Lead/Lag operation is possible only when the units are installed in parallel:

- The Lead-Lag assembly is controlled on the water inlet without any additional sensors (system return) (Example 1).
- This can also be done on the water outlet with the addition of two additional sensors on the common pipe (see Example 2).

Each unit controls its own water pump.

Units supplied without hydraulic module

In the case of units installed in parallel, and if there is only one common pump installed by the installer, isolating valves must be installed on each unit. These should be controlled (opened and closed) using the control for the relevant unit (valves for each unit can be controlled using the unit water pump control outputs). Refer to the control manual for the connections.

In this case, a variable-speed pump must be controlled by the unit via the 0-10 V dedicated output of the lead unit (control on Delta T only).

An installation in series is only possible with a fixed speed pump (See Example 3):

- The operation of the pump will be controlled by the lead unit.
- The Lead/Lag assembly is controlled on the water outlet without additional sensor.
- The installation must be carried out only by following the diagram provided in Example 3.

IMPORTANT:

Both of the units must be equipped with an option to allow Lead-Lag operation.

If one or both units is equipped with the variable-speed pump option, it is strongly recommended not to set the control mode on the pressure differential. The same setpoint is recommended for configuring the temperature differential mode.

Example 1: Operation in parallel - control on water inlet for a hydraulic module

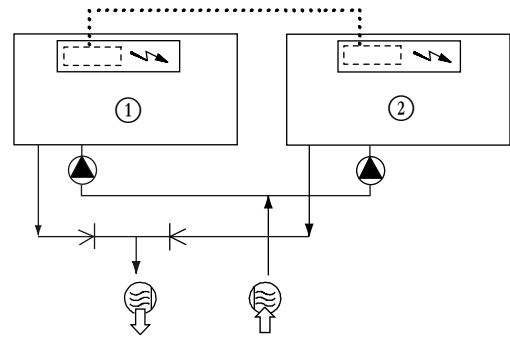

Example 2: Operation in parallel - control on water outlet for a hydraulic module

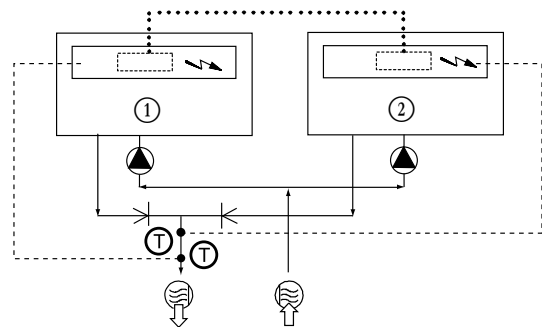

Example 3: Operation in series - control on water outlet for a unit assembly

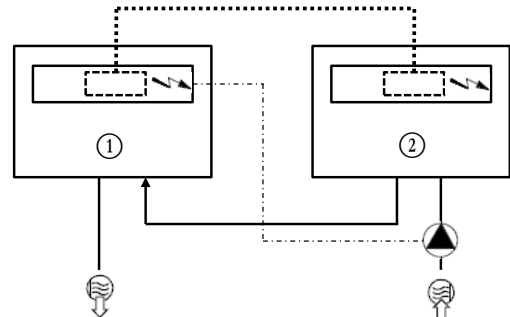

Key:

All dimensions are given in mm.

- ① Lead unit
- ② Lag unit
- Water inlet
- ← Water outlet
- ⚡ Control boxes of the lead and lag units
- ▲ Water pumps for each unit (normally included in the units with hydraulic module)
- T Additional sensor for water outlet control, to be connected to channel 1 of the lag boards of each lead and lag unit
- CCN communication bus
- Connection of two additional sensor
- ⌞ Non-return valve

12 - OPTIONS

12.2.5 - Units with fans with available pressure (Option 12)

12.2.5.1 - General information

The design of this range using R32 is intended for outdoor installation. For more details on the installation scenarios, refer to the installation guide for A2L refrigerants.

Each fan is controlled by a variable speed drive. Therefore each circuit operates independently and must have a separate duct system to avoid any air recycling between the condensers of the different refrigerant circuits.

On the 30RB/RQ units, each fan includes a factory-mounted connection frame interface for the connection to the duct network of the specific refrigerant circuit to which the fan belongs.

For the precise dimensions of this connection interface please refer to the dimensional drawings for the units.

12.2.5.2 - Fan discharge connection

A square flange is supplied mounted on the unit. An available standard round flange can easily be installed at the fan discharge, if the installer prefers the use of a round connection duct.

The unit is supplied with a grille on the discharge side. This grille has to be removed before connection to the duct system.

It is advisable to make the connection to the duct system with a flexible sleeve. If this recommendation is not observed, a lot of vibration and noise may be transmitted to the building structure.

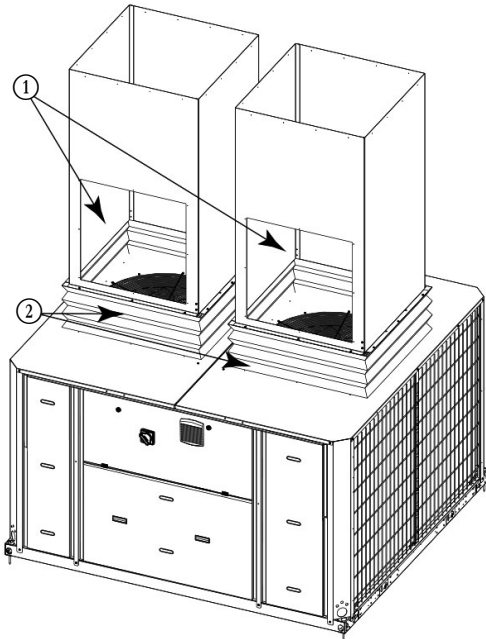

Unit with grille protection option

NOTE: The discharge lines must be ducted separately.

- ① Fan motor access hatches (700 x 700 mm hatch) for each single and dual duct
- ② Connection bellows or sleeve

IMPORTANT: The connection of the ducts to the units must not lead to a mechanical constraint on the decks supporting the fans. Use bellows or flexible sleeves to connect the ducts.

At the beginning of each duct, provide an access hatch with minimum dimensions of 700 x 700 mm to allow replacement of the motor or removal of the fan scroll.

12.2.6 - Units with coil frame for fresh air duct connection (Option 12A)

12.2.6.1 - General information

Units with option 12A can be installed inside a building and connected to an air distribution duct network:

- Fan discharge side and fresh air intake side for units 30RB/RQ 040 to 080,
- Fan discharge side of the unit (30RB /RQ 040 to 160).

For the precise dimensions of this connection interface please refer to the dimensional drawings for the units.

12.2.6.2 - Standard unit suction line connection (option 12A or 23B)

Units equipped with option 12A or 23B are supplied with a sleeve that allows connection of an air heat exchanger suction duct. Provide a removable window on the suction duct to allow the maintenance of the sensor (see figure below).

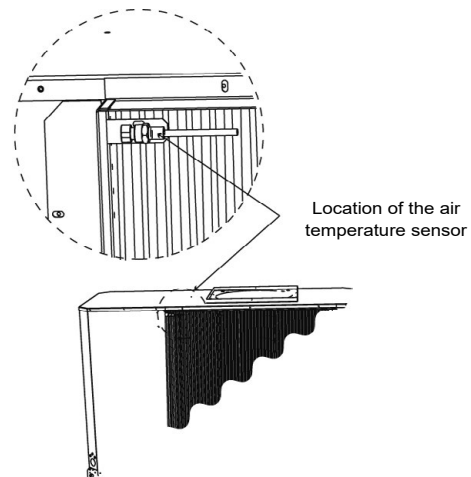

For units 30RQ 60R to 80R, the air heat exchanger is on two sides of the unit. It is therefore necessary to install two additional brackets to allow connection of the heat exchanger suction duct.

These parts are inside the machine and fixed to the riser (as shown on the diagram below) with plastic collars.

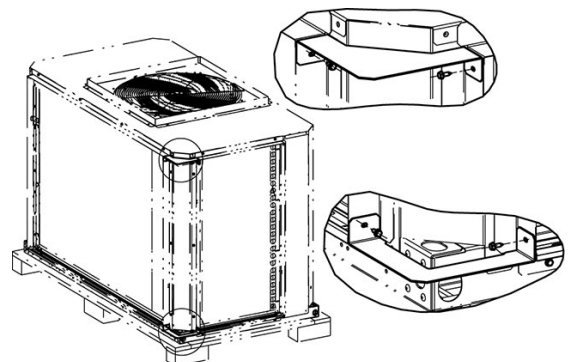

**Specific precautions for connection
for sizes 60R to 80R on the 30RQ model
with Option 12A or 23B**

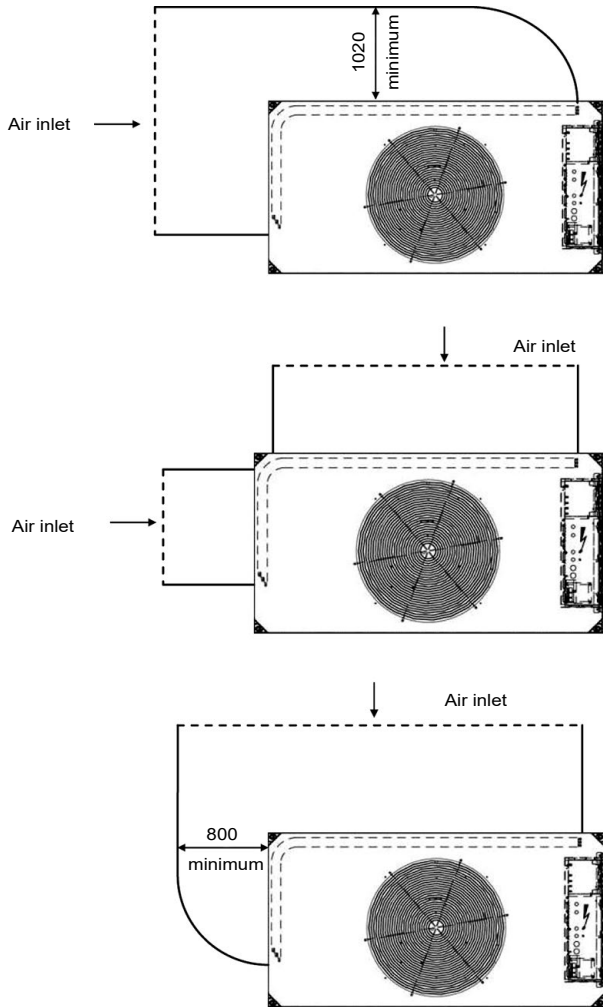

All dimensions are given in mm.

12.2.6.3 - Air heat exchanger suction filter kit (option 23b)

This option is available for units 30RB/30RQ 040 to 080. The suction duct is connected directly to the factory-mounted sleeve on the unit. Maintenance access to the filters is achieved by removing the four metric screws on the side of the sleeve.

The cover panel with a manoeuvring lever can now be removed. The filters are placed on a metal sheet that allows them to slide in their support.

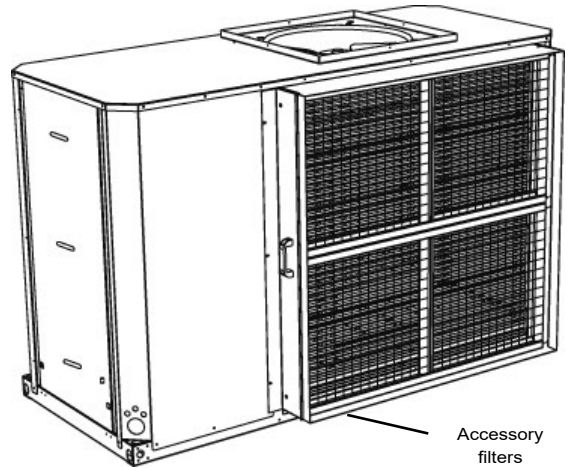

12 - OPTIONS

12.2.6.4 - Fan motor electrical protection

Each motor is controlled by its own variable-speed controller. Electrical protection is ensured by the variable-speed controller (in case of a locked rotor or overload).

If a fan does not operate, the speed regulator will automatically detect this and an alert will be sent to the SmartVu™ display. Refer to the control manual for the list of alarms specific to this option.

Selection based on the pressure drop

The cooling capacities are given for an available pressure of 160 Pa and for a unit without filter.

To calculate the performances at other pressure drops, please use the correction factors below.

30RB/RQ 040R - 055R

Duct pressure drop	Fan speed, r/s	Power input coefficient	Cooling capacity coefficient
0	12,00	0,943	1,019
50	13,33	0,962	1,012
100	14,66	0,980	1,006
130	15,46	0,990	1,003
160	16,26	1,000	1,000
200	17,31	1,012	0,998
240	18,36	1,023	0,996

30RB/RQ 060R - 160R

Duct pressure drop	Fan speed, r/s	Power input coefficient	Cooling capacity coefficient
0	15,83	0,929	1,018
50	16,81	0,944	1,016
100	17,78	0,964	1,014
130	18,36	0,978	1,011
160	18,36	1,000	1,000
180	18,36	1,019	0,991

Notes:

Pressure drop, clean filter = 6 Pa

Pressure drop, dirty filter = 12 Pa

12.2.7 - Brine option (Option 6B)

This option enables brine to be produced down to -8°C. The unit is equipped with suction pipe insulation and a fan frequency converter.

The operating range depends on the suction pressure, which itself depends on the following factors:

- The brine type,
- The brine concentration,
- The flow rate,
- The brine temperature,
- The condensing pressure (ambient temperature).

Example: For operation with 30% ethylene glycol and a brine temperature of -8°C (with -3°C at the inlet), the maximum operating ambient temperature will be approximately 35°C.

Refer to the section relating to the operating ranges

12.2.7.1 - Frost protection

The evaporator low pressure and frost protection depends on the amount of antifreeze added to the water circuit. The operating principle for the evaporator (LWT - SST) and the frost protection are based on this amount.

It is therefore essential to check the amount of antifreeze in the water loop at the first start-up (circulate for 30 minutes to ensure the mixture is distributed uniformly before taking the sample). Refer to the manufacturer's data to define the frost protection, based on the concentration rate measured.

The frost protection temperature must be used in the unit software parameters.

This value will allow the definition of the following limits:

1. Evaporator frost protection
2. Low pressure protection

It is recommended that the commissioning of a brine system is done by Carrier.

12 - OPTIONS

For information: The protection values given by our supplier, based on the antifreeze solutions used in the Carrier Montluel laboratory, are as follows: (these values can change for different suppliers).

% glycol mass	Freeze point, °C ethylene glycol	Freeze point, °C propylene glycol
10	-3,8	-2,6
15	-6,1	-4,3
20	-8,8	-6,6
25	-11,8	-9,6
30	-15,2	-13
35	-19,1	-16,7
40	-23,6	-20,7
45	-29	-25,3

Based on the table below, if the ethylene glycol concentration by weight in the water loop is 35%, the value of -19.1°C must be used in the software.

It is essential to check the amount of glycol at least once a year, and adjust the frost protection value in the software based on the proportion measured. This procedure must be performed each time water or antifreeze solution is added.

The curve below shows the minimum frost protection activation temperature that must be observed, based on the leaving water temperature.

Minimum frost protection activation temperature

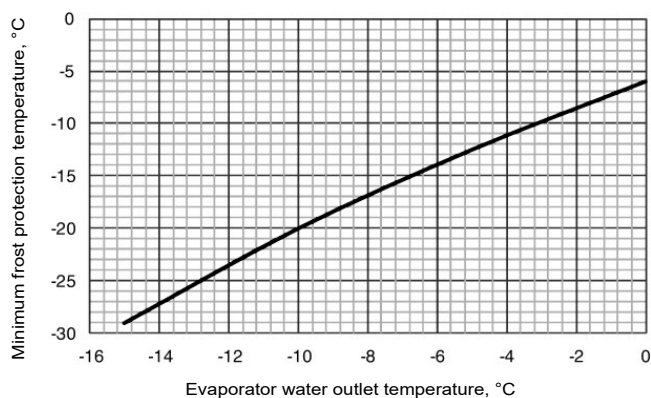

12.2.7.2 - Physical data - 6B option

30RB	040R	045R	050R	055R	060R	070R	080R	090R	100R	120R	140R	160R	
Refrigerant with option Low temperature brine solution ⁽¹⁾	R32 / A2L / GWP=675 following AR4												
Circuit A	kg	3,61	3,68	4,30	4,61	4,42	4,58	4,55	7,29	7,90	8,46	4,70	4,77
	teqCO ₂	2,4	2,5	2,9	3,1	3,0	3,1	3,1	4,9	5,3	5,7	3,2	3,2
Circuit B	kg											4,70	4,77
	teqCO ₂											3,2	3,2

30RQ	040R	045R	050R	060R	070R	080R	090R	100R	120R	140R	160R	
Refrigerant with option Low temperature brine solution ⁽¹⁾	R32 / A2L / GWP=675 following AR4											
Circuit A	kg	6,75	6,75	7,10	8,70	8,95	9,20	NA	NA	NA	8,95	9,15
	teqCO ₂	4,6	4,6	4,8	5,9	6,0	6,2	NA	NA	NA	6,0	6,2
Circuit B	kg										8,95	9,15
	teqCO ₂										6,0	6,2

(1) Valeurs données à titre indicatif. Se référer à la plaque signalétique de l'unité.

NOTES:

- For frost protection of the unit at low air temperatures, the brine percentage must be assessed.
- The maximum glycol rate for units with hydraulic kit (options 116) is 45%.
- The temperature of - 8°C brine can only be obtained with ethylene glycol at 30%.
- The maximum recommended temperature difference is 5 K.

IMPORTANT: For glycol concentrations below 20%, a corrosion inhibitor suitable for the application must be used to avoid corrosion which can be caused by the brine.

The presence of glycol reduces the life of the pump fittings. It is recommended to change the fittings or the pump:

- Every 40,000 hours for applications with water,
- Every 15,000 hours for applications with glycol concentrations above 30%.

To facilitate maintenance operations, it is recommended to install shut-off valves upstream and downstream of the unit.

12 - OPTIONS

12.2.8 - Unit operation with a free cooling dry cooler (Option 313)

12.2.8.1 - Operating principle

The units have been designed to optimise the operation of the systems, using dry coolers as a free cooling system (method using low outdoor air temperatures to chill the water in the air conditioning system).

This system enables substantial energy and cost savings, and is at its most effective when the outdoor air temperature is low.

The unit's SmartVu™ control system includes algorithms which enables the following to be constantly automatically optimised:

- The operation of the dry cooler fans,
- The variation of the flow rate in the water loop,
- The cooling capacity (the dry cooler and chiller can operate independently or simultaneously),
- The positions of the valves, depending on the operating mode.

The control defines the optimal configuration, taking the water setpoint value, outdoor air temperature, and water loop temperature into account (the control will give priority to the dry cooler).

Parallel control of the fans and of the variable flow rate in the water loop enable the system to operate at outdoor temperatures of down to -20°C without any additional control.

Warning: The dry cooler and chiller both need to be equipped with the Free cooling management option.

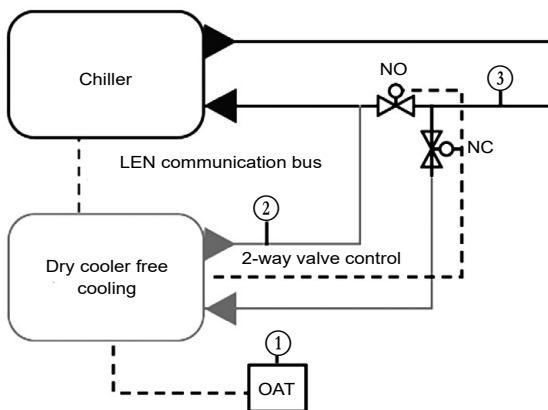

For an optimal free cooling operation, the chiller has to be configured:

- Using the water inlet temperature control,
- Using the temperature delta control for the variable-speed pump option.

12.2.8.2 - Communication to control the dry cooler

When the option is selected, a specific electronic board is integrated in the control box of the dry cooler. A communication LEN bus connected between the dry cooler (board AUX1) and the chiller is needed for the overall system control.

This cable must be a 3-point Wago type cable (5 mm spacing or equivalent) and must be shielded.

The board integrated in the control box of the dry cooler has analogue inputs for outside air temperature (mark 1), return water loop temperature (mark 3) and dry cooler leaving water temperature sensors (mark 2), as well as digital outputs permitting the control of the fans.

The option works as a system split in two parts:

The chiller (with free cooling option):

- Dedicated control algorithms with LEN connector to communicate and control the dry cooler.

The dry cooler (with free cooling option):

- AUX board with the I/O,
- Room air temperature sensor to be placed outdoors,
- Dry cooler water outlet temperature sensor (factory-fitted),
- Water loop temperature sensor (to be fitted on the common pipe upstream of the valve),
- Control & 230V power supply for 2 two-way valves or 1 three-way valve.

The difference between the dry cooler outdoor air temperature and the water loop sensor temperature determines whether or not it is possible to activate free cooling mode.

12.2.8.3 - Configuration of the fan control

To set the configuration corresponding to the dry cooler installed (number of fans, control type – fixed or variable speed), please refer to the instructions in the SmartVu™ control manual. Using these parameters, the SmartVu™ control will activate the correct number of outputs to control the fans.

SmartVu™ controls the automatic switching of all fans, based on operating time and number of start-ups, to ensure the fan motors provide a long service life.

Compatible fans configuration:

- 1 to 20 fans,
- Fixed speed or variable speed,
- 1 or 2 rows of fans.

Refer to the dry cooler wiring diagram to see the arrangement of the fan stages.

12.2.8.4 - Valves on the water loop

The free cooling system requires 2 two-way valves (one normally open, one normally closed) or a three-way valve, not supplied with the unit or the dry cooler.

A two-way valve kit is available in the list of accessories for the dry cooler.

The dry cooler electrics box has a 230 V power supply for 2 two-way valves.

Recommended motor valve (per default): 230 V 3 points.

See the dry cooler wiring diagram for cabling the valves to the customer terminal strip.

12.2.8.5 - Guidelines for system installation

For physical characteristics, dimensions, performances: Refer to the dry cooler documentation.

For the electrical connections, see the electrical wiring diagram supplied with the dry cooler.

For software configuration information, refer to the control documentation of the chiller.

For a proper dry cooler installation, follow the professional guidelines for the following topics:

- Sizing of the water piping;
- Pressure drops (verify that the operating pressure of the unit pump is sufficient compared to the pipe and valve pressure drops; check for all operating modes);
- Maximum height for the dry cooler (in relation to the unit safety valve);
- Good positioning for temperature sensors: Outside air temperature and water loop temperature.

13 - STANDARD MAINTENANCE

To ensure optimal efficiency and reliability of the equipment and all its functions, we recommend taking out a maintenance contract with the local organisation set up by your manufacturer. This contract will include regular inspections by the manufacturer's Service specialists so that any malfunction is detected and corrected quickly, ensuring that no serious damage can occur. The manufacturer's service maintenance contract is the best way to ensure the maximum operating life for your equipment and, through the expertise of manufacturer's qualified personnel, provides the ideal way to manage your system energy consumption effectively.

The refrigeration equipment must be serviced by professionals; however, routine checks may be carried out locally by specially-trained technicians. See standard EN 378-4.

All refrigerant charging, removal and draining operations must be carried out by a qualified technician and with the correct equipment for the unit. Any inappropriate handling can lead to uncontrolled fluid or pressure leaks.

IMPORTANT:

Before performing any work on the unit ensure it is de-energized. If a refrigerant circuit is opened, it must be evacuated, recharged and tested for leaks. Before any operation on a refrigerating circuit, it is necessary to evacuate the refrigerant charge from the device using a load transfer unit.

Simple preventive maintenance will allow you to get the best performance from your HVAC unit:

- Optimisation of energy performance,
- Reduced electricity consumption,
- Prevention of accidental component failure,
- Prevention of major time-consuming and costly work,
- Protection of the environment.

13.1 - Maintenance levels

- Level 1 maintenance must be performed by the operator,
- Level 2 maintenance must be performed by the maintenance service,
- Level 3 maintenance must be performed by a maintenance service authorised to work on refrigerant circuits.

NOTE: Any deviation from or failure to comply with these maintenance criteria will render the guarantee conditions for the refrigeration unit null and void, and will release the manufacturer from its liability.

13.2 - Level 1 maintenance

These simple procedures can be carried out by the user:

- Visual inspection for oil traces (sign of a refrigerant leak),
- Check for leaks in the circuit (monthly),
- Clean the air-cooled exchangers (see the dedicated chapter),
- Check that the protective grilles are present and in good condition, and that the doors and covers are properly closed,
- Check the unit's alarm report (see the control manual),
- Verify the refrigerant charge in the liquid line sight glass,
- Verify the temperature difference at the heat exchanger inlet and outlet is correct,
- Check for any general signs of deterioration,
- Check the anti-corrosion coatings.
- Check that the nameplates are always affixed to the unit
- Check that there are no flammable materials around the unit

13.3 - Level 2 maintenance

This level requires specific expertise in electrical, hydraulic and mechanical systems. It is possible that this expertise may be available locally; there may be a maintenance service, industrial site or specialist subcontractor in the area.

The frequency of this maintenance level may be monthly or annual, depending on the verification type.

In these cases, the following maintenance operations are recommended:

Carry out all level 1 operations, then:

Electrical checks (annual checks):

- At least once a year tighten the electrical connections for the power supply circuits (see tightening torques table),
- Check and tighten all control connections, if required,
- Check the labelling of the system and instruments, re-apply the missing labels if required,
- Remove the dust and clean the interior of the electrical boxes. Be careful not to blow dust or debris into components; use a brush and vacuum wherever possible,
- Clean the insulators and bus bar supports (dust combined with moisture reduces the insulation gaps and increases current leakage between phases and from phase to ground),
- Check the presence, condition and operation of electrical protective devices,
- Check the presence, condition and operation of control components,
- Check that all heaters are operating correctly,
- Replace the fuses every 3 years or every 15000 hours (ageing),
- Check that no water has penetrated into the electrical box,
- On the main electrical box and for units equipped with offset electrical boxes, regularly check the cleanliness of the filter media to maintain the correct air flow.
- Check that the circuit breaker works correctly (Power factor correction option).

13 - STANDARD MAINTENANCE

Mechanical checks:

- Check that the mounting bolts for the ventilation sub-assemblies, fans, compressors and electrics box are securely tightened

Hydraulic checks:

- When working on the water circuit, take care not to damage the adjacent air heat exchanger,
- Check the water connections,
- Check the condition of the expansion tank (presence of corrosion or loss of gas pressure) and replace it if required,
- Drain the water circuit (see chapter "Water flow control procedure"),
- Clean the water filter (see chapter "Water flow rate control procedure"),
- Replace the gland packing of the pump after 20000 hours of operation and the bearings after 17500 hours,
- Check the operation of the low water flow safety device,
- Check the condition of pipe thermal insulation,
- Check the concentration of the anti-freeze protection solution (ethylene glycol or propylene glycol),
- Check the water flow via the heat exchanger pressure difference,
- Check the condition of the heat-transfer fluid or the water quality,
- Check for corrosion of the steel pipe work.

Refrigerant circuit checks:

- The unit is subject to F-gas tight regulatory checks. Please refer to the table in the introduction.
- Check the unit operating parameters and compare them with the previous values,
- Check the operation of the high-pressure switches. Replace them if there is a fault,
- Check the fouling of the filter drier. Replace it if required,
- Keep an up-to-date service booklet specific to the refrigeration unit in question.

IMPORTANT: Ensure all adequate safety measures are taken for all these operations: Use appropriate PPE (personal protective equipment), comply with all applicable industry and local regulations, and use common sense.

13.4 - Level 3 maintenance

Maintenance at this level requires specific skills, qualifications, tools and expertise. Only the manufacturer, his representative or authorised agent are permitted to carry out this work.

This maintenance work relates to the following:

- Replacement of major components (compressor, water heat exchanger),
- Operations on the refrigerant circuit (handling refrigerant),
- Modification of factory-set parameters (change of application),
- Movement or disassembly of the refrigeration unit,
- Any operation due to proven lack of maintenance,
- Any operation covered by the warranty,
- One or two leak detection operations per year performed by qualified personnel using a certified leak detector.
- To reduce waste, the refrigerant and the oil must be transferred in accordance with applicable regulations, using methods that limit refrigerant leaks and pressure drops and with materials that are suitable for the products.
- Any leaks detected must be repaired immediately
- The compressor oil that is recovered during maintenance contains refrigerant and must be treated accordingly.
- Pressurised refrigerant must not be vented to the open air.
- If the refrigerating circuit must be opened, cap all openings for a period of up to one day. If open for longer, blanket the circuit with a dry, inert gas (e.g. nitrogen).

13 - STANDARD MAINTENANCE

13.5 - Tightening of the electrical connections

Component	Description	Value (N.m)
Soldered screw (PE) customer connection		
M8	PE	14,5
Screw on terminal inlet board		
Terminal 56.395.0055.0	X100	10
Terminal 56.398.0055.0		14
Terminal screw, main circuit breaker		
Disconnect switch - MG 28908	QS_	8
Disconnect switch - MG 28910		8
Disconnect switch - MG 28912		8
Disconnect switch - MG 28949		8
Cage terminal screw, compressor contactor		
LC1D18B7		1,7 control section 1,7 power section
LC1D25B7		1,7 control section 2,5 power section
LC1D32B7		1,7 control section 2,5 power section
LC1D40AB7		1,7 control section 5 power section (1 to 25 mm ² cable)
LC1D50AB7		1,7 control section 5 power section (1 to 25 mm ² cable)
Cage terminal screw, compressor fuse holder		
Fuse holder DF223C	FU*	4
Fuse holder DF143C		3,5
Cage terminal screw, compressor soft starter		
Soft Starter 3RW4028-1BB04	GS*	1,2 control section 4,5 power section
Soft Starter 3RW4036-1BB04		1,2 control section 4,5 power section
Soft Starter ATS01N232QN399		Starter terminals 1L1, 2T1, 3L2, 4T2, 5L3, 6T3= 1,9 to 2,5 Starter terminals R1A, R1C, COM, LI, LI2, L01, BOOST= 0,5
Tunnel terminal screw, control power transformer		
Transformer - 40958E	TC	0,6
Transformer - 40959E		
Transformer - 40888E		
Transformer - 40894E		
Compressor earth terminal in the power wiring control box		
M6	Gnd	5,5
Compressor earth connection		
M8	Gnd	2,83
Case terminal screw, circuit breaker (fan, pump)		
Circuit breaker A9F94204	QM*	2
Circuit breaker A9F94206		2
Circuit breaker GV2DP120B7		1,7 contactor side 1,7 circuit breaker side
Circuit breaker GV2DP132B7		1,7 contactor side 1,7 circuit breaker side
Circuit breaker GV2ME06		1,7
Circuit breaker GV2ME07		1,7
Circuit breaker GV2ME08		1,7
Circuit breaker GV2ME10		1,7
Circuit breaker GV2ME14		1,7
Circuit breaker GV2RT07		1,7
Circuit breaker GV2RT08		1,7
Circuit breaker GV2RT10		1,7
Tunnel terminal screw, contactor (fan, pump)		
LC1K0610B7	KM*	1,3
LC1K09004B7		1,3
LC1K0901B7		1,3
LC1K0910B7		1,3
LA1KN20		1,3
LA1SK02		0,8
LADN11		1,7
Cage terminal screw, EMC filter (fan, pump)		
EMC filter VW3A31404	ZGS*	1,8
EMC filter VW3A31406		1,8
Cage terminal screw, control panel fan		
NSYCCOTHC	EV*	0,5
NSYCCOTH0		0,5
Cage terminal screw, control relay		
Relay CA2SK20B7	K*	0,8

13 - STANDARD MAINTENANCE

13.6 - Tightening torques for the main fastenings

Screw type	Use	Value (N.m)
Compressor rail	Compressor bracket	30
M10 nut	BPHE ⁽¹⁾ fixing	18
M10 nut	Compressor assembly	30
M16 nut	Compressor mounting	30
Oil nut	Oil equalisation line	75
Taptite screw M6	Fan support	7
Taptite screw M8	Fan motor fixing	13
M8 hex screw	Impeller fixing	18
Panel screw	Panel part fixing	4,2
M6 hex screw	Stauff collar	10

(1) BPHE = Brazed Plate Heat Exchanger

13.7 - Air-cooled exchanger

We recommend that coils are inspected regularly to check the degree of fouling. This depends on the environment where the unit is installed, in particular urban and industrial sites, and for units installed near trees that shed their leaves.

Recommendations for maintenance and cleaning of air heat exchangers:

- Regularly cleaning the coil surface is essential for correct unit operation.
- Eliminating contamination and removal of harmful residue will increase the operating life of the coils and the unit.
- The maintenance and cleaning procedures below are part of the regular maintenance to increase the operating life of coils.
- Specific recommendation in case of snow: For long term storage, regularly check that no snow has accumulated on the coil.

Specific RB equipped with MCHes:

- Clean the surface of the coil by spraying the coil regularly and uniformly from bottom to top, orienting the water jet at right angles to the surface. Do not exceed a water pressure of 6200 kPa (62 bar) or an angle of 45° in relation to the coil. The nozzle must be at least 300 mm away from the coil surface.
- Clean and scrub the entire connection with a flexible Nylon, PolyPro® or Tynex® brush and low-pressure tap water.

Level 1 cleaning:

- Remove all foreign objects or debris attached to the surface of the coil or wedged between the casing and the supports
- Use a low pressure dry air jet to remove all traces of dust from the coil.

Level 2 cleaning:

- Carry out the level 1 cleaning operations.
- Clean the coil using suitable products.

Use appropriate PPE including safety glasses and/or mask, waterproof clothes and safety gloves. It is recommended to wear clothing that covers the whole body.

Specific products approved by the manufacturer for cleaning coils are available from the manufacturer's spare parts network. The use of any other product is strictly prohibited. After the cleaning product is applied, rinsing with water is mandatory (see manufacturer's standard RW01-25).

IMPORTANT:

Never use a pressure water spray without a large diffuser.

Concentrated and/or rotating water jets are strictly forbidden.

Never use a fluid with a temperature above 45°C to clean the air heat exchangers.

Correct and frequent cleaning (approximately every three months) will prevent two thirds of corrosion problems. Protect the electrics box during cleaning operations.

13.8 - Water type heat exchanger

Check that:

- The insulation has not been detached or torn during operations,
- The heaters and probes are operating and correctly positioned in their support,
- The water-side connections are clean and show no sign of leakage,
- The period inspections required by the local regulations have been carried out.

13.9 - Frequency inverter

IMPORTANT: Before any work on the variable frequency drive, ensure that the circuit is isolated and there is no voltage present (reminder: The capacitors take approximately 5 minutes to discharge once the circuit breaker has been opened). Only appropriately qualified personnel are authorised to work on the variable frequency drive.

In case of any alarm or persistent problem related to the variable frequency drive, contact the manufacturer's service department.

The variable frequency drives fitted on the units do not require a dielectric test, even if being replaced: They are systematically checked before delivery. Moreover, the filtering components installed in the variable frequency drive can falsify the measurement and may even be damaged. If there is a need to test the insulation of the unit components (fan motors and pumps, cables, etc.), the variable frequency drive must be disconnected from the power circuit.

13 - STANDARD MAINTENANCE

13.10 - Refrigerant volume

It is essential to run the unit in cooling mode to find out whether the charge is correct; this is done by checking the actual subcooling. Following a slight leak, it will be possible to detect a drop in the refrigerant charge from the initial charge, and this will affect the subcooling value obtained at the air-cooled exchanger outlet; it cannot, however, be detected in heating mode.

13.11 - Refrigerant properties

R32 properties

Saturated temperatures (°C) based on the relative pressure (in kPa)							
Satur. temp.	Relative pressure	Satur. temp.	Relative pressure	Satur. temp.	Relative pressure	Satur. temp.	Relative pressure
-20	306	4	822	28	1730	52	3189
-19	321	5	851	29	1778	53	3264
-18	337	6	881	30	1828	54	3341
-17	354	7	912	31	1878	55	3420
-16	371	8	943	32	1929	56	3500
-15	388	9	974	33	1982	57	3581
-14	406	10	1007	34	2035	58	3664
-13	424	11	1040	35	2090	59	3748
-12	443	12	1074	36	2145	60	3833
-11	463	13	1109	37	2202	61	3920
-10	483	14	1144	38	2260	62	4009
-9	503	15	1181	39	2318	63	4099
-8	524	16	1218	40	2378	64	4191
-7	546	17	1256	41	2439	65	4284
-6	568	18	1295	42	2501	66	4379
-5	591	19	1334	43	2565	67	4476
-4	614	20	1375	44	2629	68	4575
-3	638	21	1416	45	2695	69	4675
-2	662	22	1458	46	2762	70	4777
-1	687	23	1501	47	2830		
0	713	24	1545	48	2899		
1	739	26	1635	49	2969		
2	766	25	1590	50	3041		
3	794	27	1682	51	3114		

14 - FINAL SHUTDOWN

14.1 - Shutting down

Separate the units from their energy sources, allow them to cool then drain them completely.

14.2 - Recommendations for disassembly

Read information relating to the presence of potentially dangerous substances in the product and their precautions for use (REACH, Regulation no. 1907/2006). This information is available on the Manufacturer's website.

Use the original lifting equipment.

Sort the components according to their material for recycling or disposal, in accordance with regulations in force.

Check whether any part of the unit can be recycled for another purpose.

14.3 - Fluids to be recovered for treatment

- Refrigerant (In compliance with regulation F-GAS no. (EU) 2024/573)
- Heat-transfer fluid: Depending on the installation, water, brine solution, etc.
- Compressor oil

14.4 - Materials to be recovered for recycling

- Steel
- Copper
- Aluminium
- Plastics
- Polyurethane foam (insulation)

The proportions of materials for each unit are listed in the Product Environmental Profile (PEP) available at the following website:
<http://www.pep-ecopassport.org/fr/consulter-les-pep/>

14.5 - Waste Electrical and Electronic Equipment (WEEE)

At the end of its life, this equipment must be disassembled and contaminated fluids removed by professionals and processed via approved channels for electrical and electronic equipment (WEEE).

15 - UNIT START-UP CHECKLIST FOR INSTALLERS PRIOR TO CONTACTING THE MANUFACTURER

Preliminary information

Job name:
 Location:
 Installing contractor:
 Distributor:
 Start-up performed by On

Equipment

Model Serial number

Compressors

Circuit A

1. Model
 Serial number
 2. Model
 Serial number
 3. Model
 Serial number
 4. Model
 Serial number

Circuit B

1. Model
 Serial number
 2. Model
 Serial number
 3. Model
 Serial number
 4. Model
 Serial number

Air handling equipment

Manufacturer:
 Model Serial number

Additional air handling units and accessories.....

Preliminary equipment check

Is there any shipping damage? If so, where?

 Will this damage prevent unit start-up?

- The unit is installed level
- The power supply corresponds to the unit nameplate
- Electrical circuit wiring has been sized and installed properly
- Unit ground wire has been connected
- Electrical circuit protection has been sized and installed properly
- All terminals are tight
- All cables and thermistors have been inspected for crossed wires
- All plug assemblies are tight

Check air handling systems

- All air handling units are operating
- All chilled water valves are open
- All fluid piping is connected properly
- All air has been vented from the system
- Chilled water pump is operating with the correct rotation. CWP current: Assigned:..... Actual.....

15 - UNIT START-UP CHECKLIST FOR INSTALLERS PRIOR TO CONTACTING THE MANUFACTURER

Unit start-up

- Chilled water pump contactor has been correctly cabled with the chiller
- Oil level is correct
- The unit has been checked for leaks (including couplings)
- Locate, repair, and report any refrigerant leaks

.....
.....
.....

Check voltage imbalance: AB..... AC..... BC.....
Average voltage = (See installation instructions)
Maximum deviation = (See installation instructions)
Voltage imbalance = (See installation instructions)

- Voltage imbalance is less than 2%

WARNING

Do not start the chiller if the voltage imbalance is greater than 2%. Contact your local power company for assistance.

- All incoming power voltage is within the nominal voltage range
- The compressor crankcase heaters have been running for 6 hours

Evaporator water loop check

Water loop volume = (litres)
Calculated volume = (litres)

- Correct loop volume established
- Correct loop corrosion inhibitor included litres of
- Correct loop frost protection included (if required) litres of
- Water piping includes electric tape heater up to the evaporator
- Return water piping is equipped with a screen filter with a mesh size of 1.2 mm

Checking the pressure drop across the evaporator (without hydraulic module) or ESP⁽¹⁾ (with hydraulic module)

Evaporator inlet = (kPa)
Evaporator outlet = (kPa)
Pressure drop (Inlet - Outlet) = (kPa)

(1) ESP: External Static Pressure

WARNING

Plot the pressure drop on the evaporator flow rate/pressure drop curve to determine the flow rate in l/s at the nominal operating conditions for the system. For units with hydraulic module, an indication of the flow rate is displayed by the unit control device (see the 30RB/30RQ control manual).

If necessary, use the control valve to adjust the flow rate to the rated value.

- Flow rate from the pressure drop curve, l/s =
- Nominal flow rate, l/s =
- The flow rate in l/s is higher than the minimum unit flow rate
- The flow rate in l/s corresponds to the specification of (l/s)

15 - UNIT START-UP CHECKLIST FOR INSTALLERS PRIOR TO CONTACTING THE MANUFACTURER

Carry out the QUICK TEST function (Consult the manufacturer's Service):

Check and log on to the user menu configuration

- Load sequence selection.....
- Capacity ramp loading selection.....
- Start-up delay
- Pump control
- Setpoint reset mode
- Night-time capacity setback.....

Re-enter the setpoints

To start the chiller

WARNING

Be sure that all service valves are open, and that the pump is on before attempting to start this machine. Once all checks have been made, try to start the unit.

The unit starts and operates properly

Temperatures and pressures

WARNING

Once the unit has been operating for a while and the temperatures and pressures have stabilised, record the following:

- Evaporator water inlet.....
- Evaporator water outlet
- Ambient temperature
- Circuit A suction pressure
- Circuit B suction pressure.....
- Circuit A discharge pressure.....
- Circuit B discharge pressure
- Circuit A suction temperature
- Circuit B suction temperature
- Circuit A discharge temperature
- Circuit B discharge temperature
- Circuit A liquid line temperature
- Circuit B liquid line temperature.....

NOTES:

.....
.....
.....



CARRIER participates in the ECP programme for LCP-HP
Check ongoing validity of certificate:
www.eurovent-certification.com

The quality management system of this product's assembly site has been certified in accordance with the requirements of the ISO 9001 standard (latest current version) after an assessment conducted by an authorized independent third party.

The environmental management system of this product's assembly site has been certified in accordance with the requirements of the ISO 14001 standard (latest current version) after an assessment conducted by an authorized independent third party.

The occupational health and safety management system of this product's assembly site has been certified in accordance with the requirements of the ISO 45001 standard (latest current version) after an assessment conducted by an authorized independent third party.

Please contact your sales representative for more information.

Order No.: 10597, 07.2024 - Supersedes order No.: 10597, 02.2023.

The manufacturer reserves the right to change the product specifications without notice.

Carrier, Montluel, France.
Printed in the European Union.