

# ALARKO

## Circulation Pump Optima



The First&Only  
According to  
Directives



AT THE HEART OF THE SYSTEM





Over 60 years of Alarko experience in Circulation Pumps...

# ALARKO OPTIMA

## Protect the nature...

Alarko intends to improve the quality of life significantly by extending its range of products with innovative products with respect for the environment and higher performance as well as significant energy-saving features. The process of adaptation to the European Union ECO Design directives resulted in a real milestone for Alarko circulation pumps: namely Alarko Optima.

### Major Benefits of Alarko Optima

1. Class-A Energy Saving
2. Ideal Performance
3. Reliability
4. Ease of Installation and Commissioning
5. After sales services and ease of supplying spare parts
6. Electronic-controlled
7. Meets SGM-2011/15 standard of Turkey and EC 641/2009 standard of the EC





# All Alarko circulation pumps already meet the requirements of 2020.

**EEI ≤ 0,23**



Unlike the traditional single and three-speed pumps, Alarko Optima serves at the ideal operation levels continuously with three different modes of operation. And this results in high energy saving.

## European Commission Eco Design Requirements for Circulation Pumps

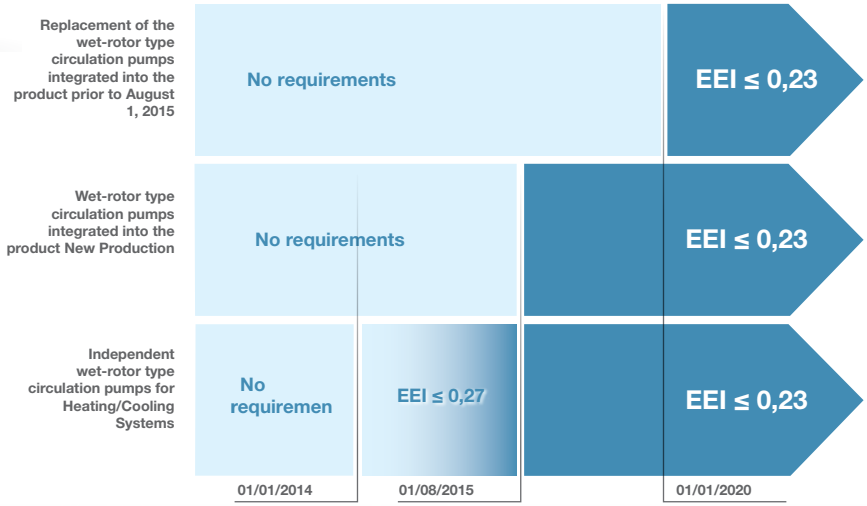

### ECM Technology offers significant advantages when compared with other motor drive technologies.

- No external sensors and controllers are necessary.
- The motor runs at lower temperatures and generates less heat.
- The motor service life is extended thanks to the low level of tension at the motor bearings.
- The levels of vibration and noise are lower.

## SAFETY

The compliance of Alarko Optima circulation pumps with the following standards and directives has been proven by the relevant tests.

- Machinery Directive 2006/42/EC
- Low Voltage Directive 2006/95/EC
- EMC Directive 2004/108/EC
- Ecodesign Directive 2009/125/EC
- TS EN 60335-2-51:2003 + A 2:2012
- TS EN 16297-1:2012
- TS EN 16297-2:2012
- TS EN 60335-1:2012

## EASE OF INSTALLATION AND COMMISSIONING

Alarko Optima circulation pumps are equipped with the connection box and connection sockets which help commissioning them rapidly and easily. These special connection sockets located on the control box allow the pump to be connected safely and rapidly without contacting the mains voltage and electronic systems.



## USER FRIENDLY LCD SCREEN

All controls and settings are performed with 5 buttons only.

- Two-line OLED screen.
- User friendly control system with Turkish software.
- English language support provided as standard in the menu.
- "Service info" feature which displays the latest 5 error codes and descriptions.





You can reach, the higher life standards with the high efficient Alarko Optima...



### General Selection Chart

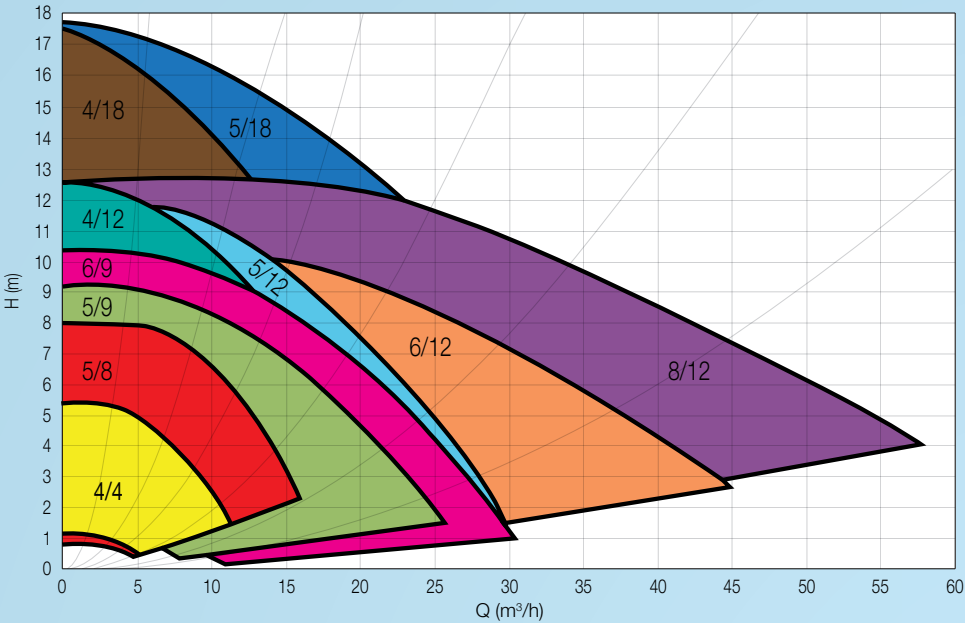

# excellence is in the details of design...

Optima circulation pumps produced with the latest technologies, with every single component designed carefully, succeeded in all the tests performed.

Designed and produced completely by Turkish engineers, Optima is one step ahead of the time...

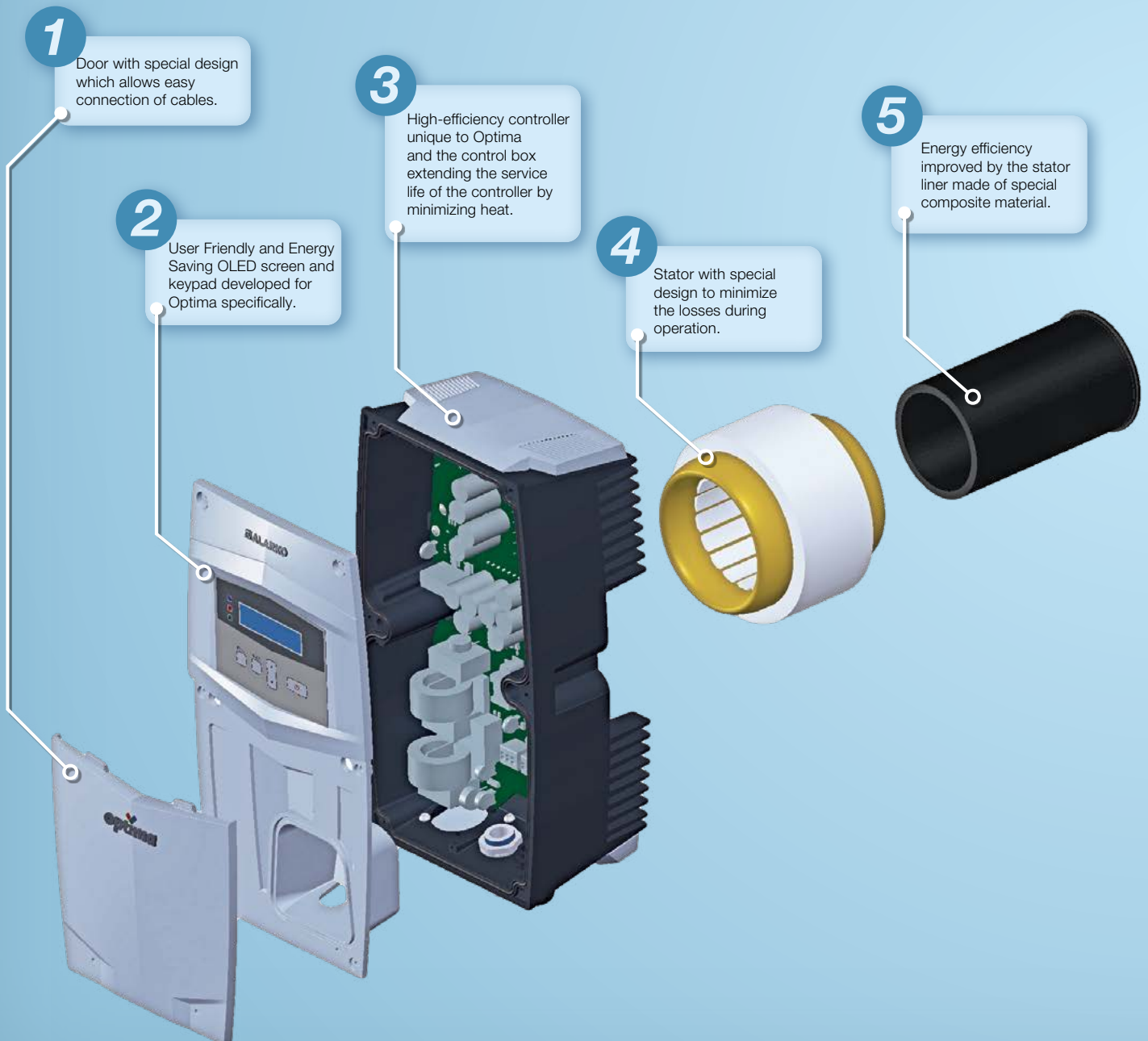



**6** High-efficiency rotor with fixed magnet maximizing the efficiency of the motor.

**7** Maintenance free and durable carbon bearings and filter made of special stainless material to prevent contaminants in the fluid from getting into the motor.

**8** Specially designed PPO fan with high hydraulic efficiency.

**9** Pump body with special design offering high hydraulic efficiency and silent operation.

**10** Polypropylene insulation liner ensuring thermal insulation of the pump body.  
*Supplied with the pump as standard.*





# OPTIMA 4/4



Maximum Pumping Height [m]	According to the pump type
Maximum Flow Rate [m <sup>3</sup> /h]	According to the pump type
Motor Speed [rpm]	1.600 – 3.700
Input Voltage and Frequency	1~ 230 V AC ± %10, 50 Hz, PE (ground protected)
Rated Current [A]	0,7
Power drawn [W]	12 – 166
Energy Efficiency Index (EEI)	< 0.23
Insulation Class	F
Protection Class	IP 44
Temperature Class	TF 110
Maximum System Pressure	PN 6/10 <sup>(1)</sup>
Sound Pressure	< 56 dB (depends on the type)
Relative Humidity	< 90%
Weight	10 kg

<sup>1</sup> Pump is suitable for use in both pressure values.

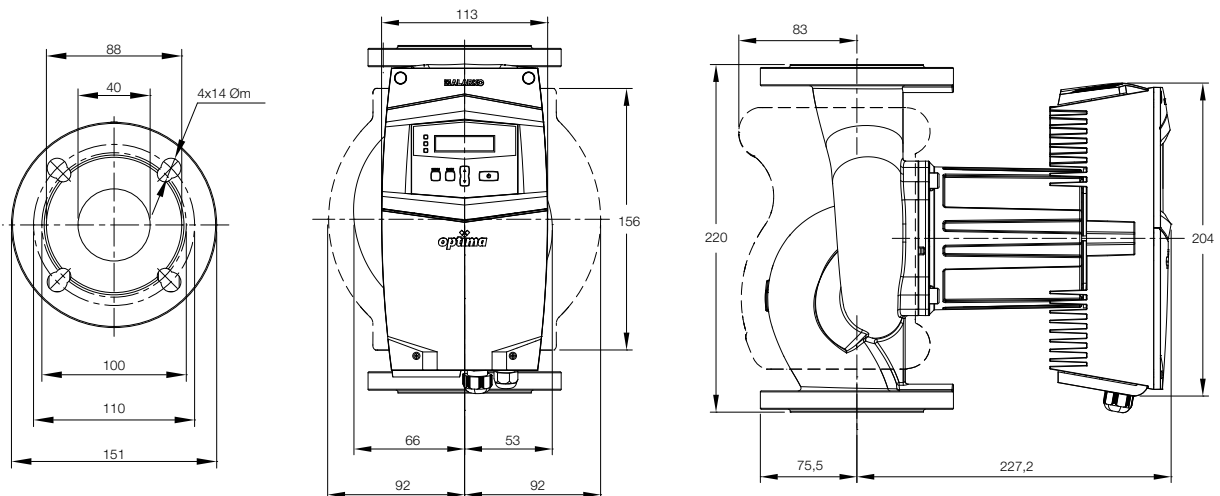



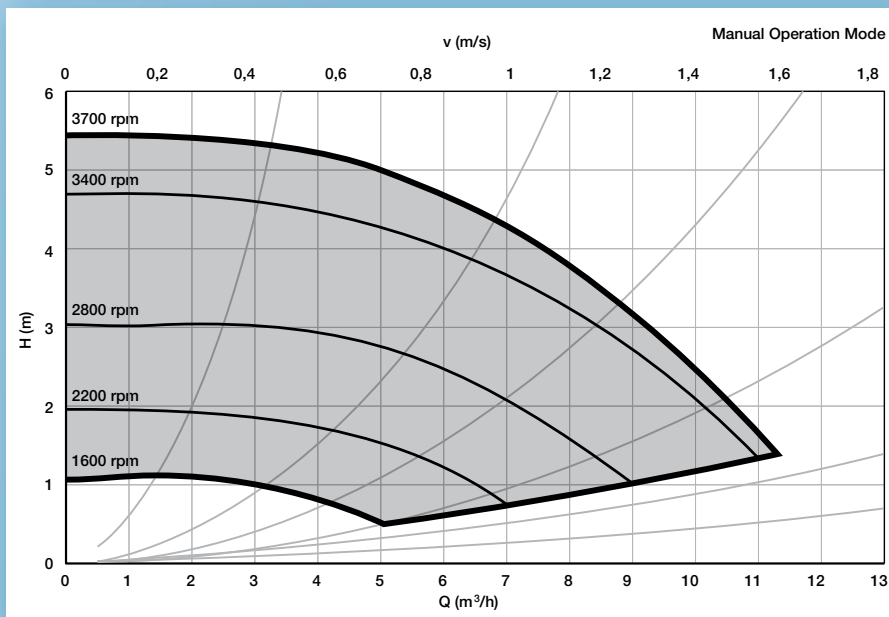
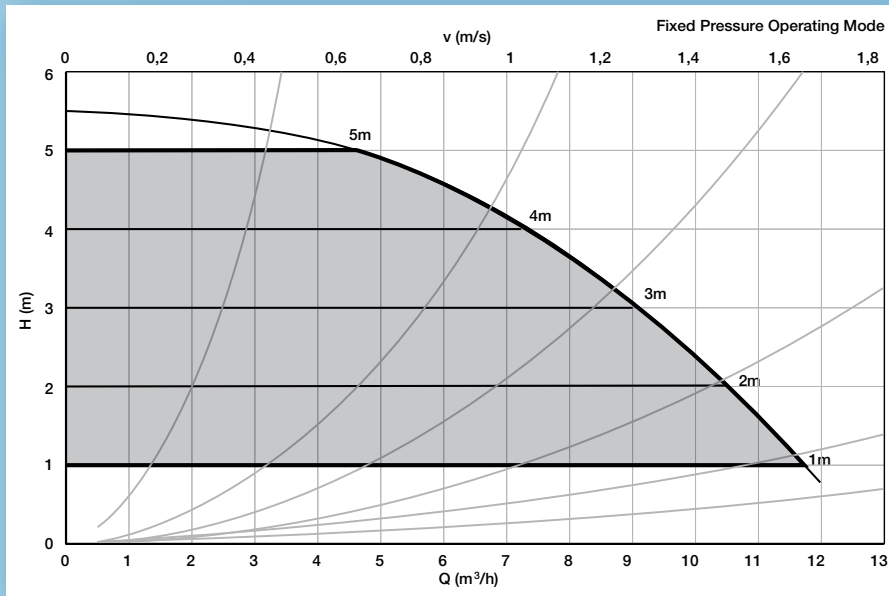
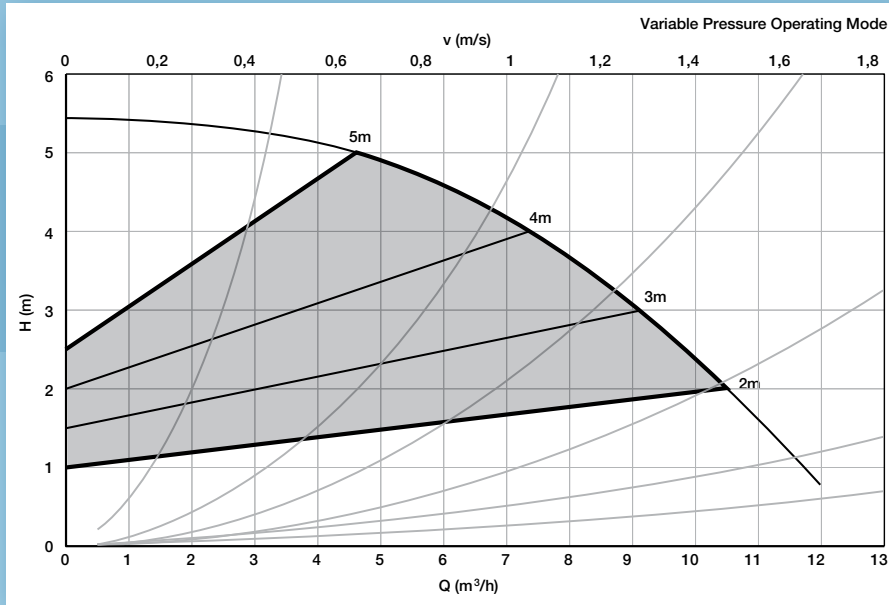



# OPTIMA 4/12



Maximum Pumping Height [m]	According to the pump type
Maximum Flow Rate [m <sup>3</sup> /h]	According to the pump type
Motor Speed [rpm]	1.400 – 4.600
Input Voltage and Frequency	1~ 230 V AC ± %10, 50 Hz, PE (ground protected)
Rated Current [A]	2,5
Power drawn [W]	33 – 550
Energy Efficiency Index (EEI)	< 0.23
Insulation Class	F
Protection Class	IP 44
Temperature Class	TF 110
Maximum System Pressure	PN 6/10 <sup>(1)</sup>
Sound Pressure	< 56 dB (depends on the type)
Relative Humidity	< 90%
Weight	14 kg

<sup>1</sup> Pump is suitable for use in both pressure values.

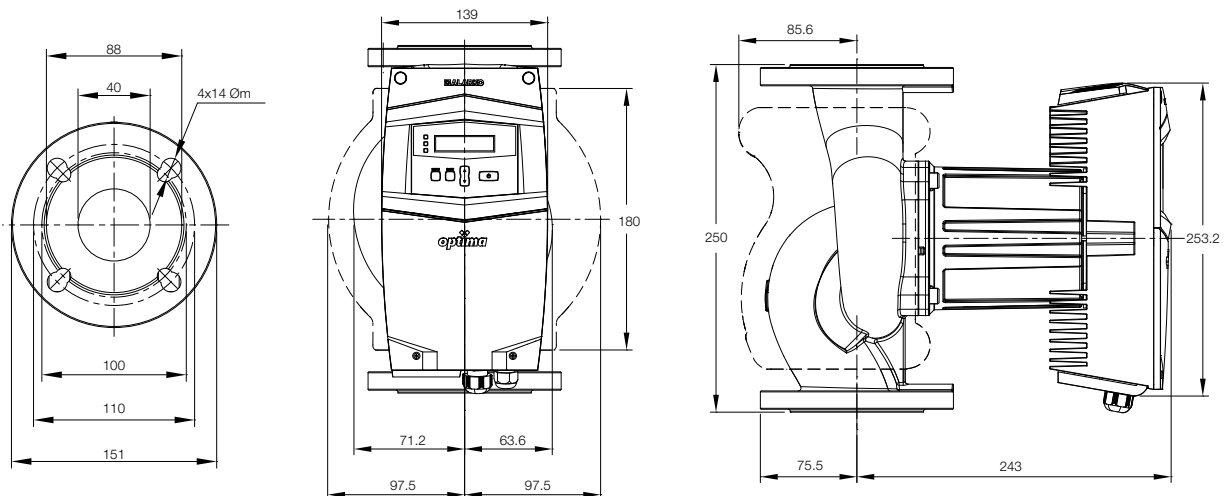

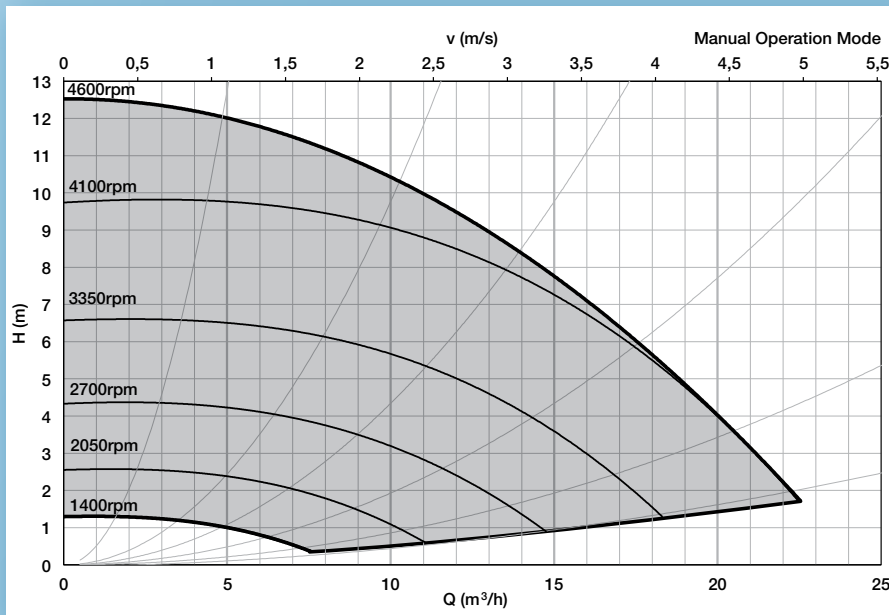
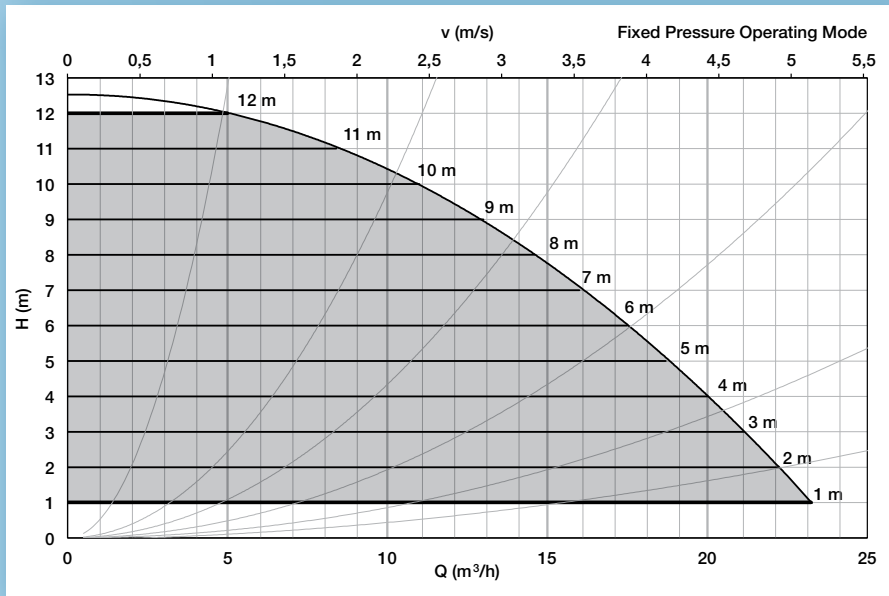
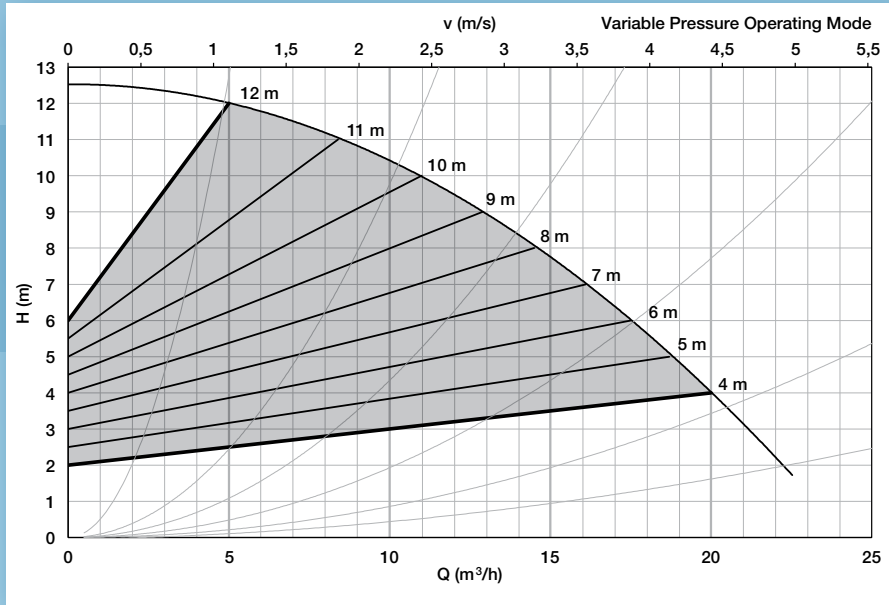





# OPTIMA 4/18



Maximum Pumping Height [m]	According to the pump type
Maximum Flow Rate [m <sup>3</sup> /h]	According to the pump type
Motor Speed [rpm]	900 – 3,600
Input Voltage and Frequency	1~ 230 V AC ± %10, 50 Hz, PE (ground protected)
Rated Current [A]	4
Power drawn [W]	25 – 880
Energy Efficiency Index (EEI)	< 0,23
Insulation Class	F
Protection Class	IP 44
Temperature Class	TF 110
Maximum System Pressure	PN 6/10 <sup>(1)</sup>
Sound Pressure	< 56 dB (depends on the type)
Relative Humidity	< 90%
Weight	21,2 kg

<sup>1</sup> Pump is suitable for use in both pressure values.

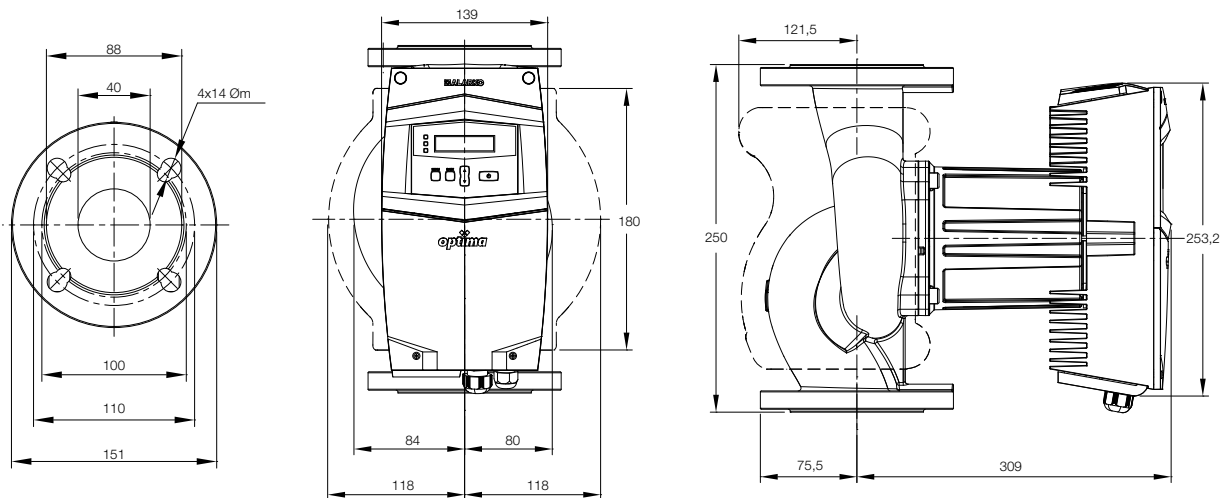

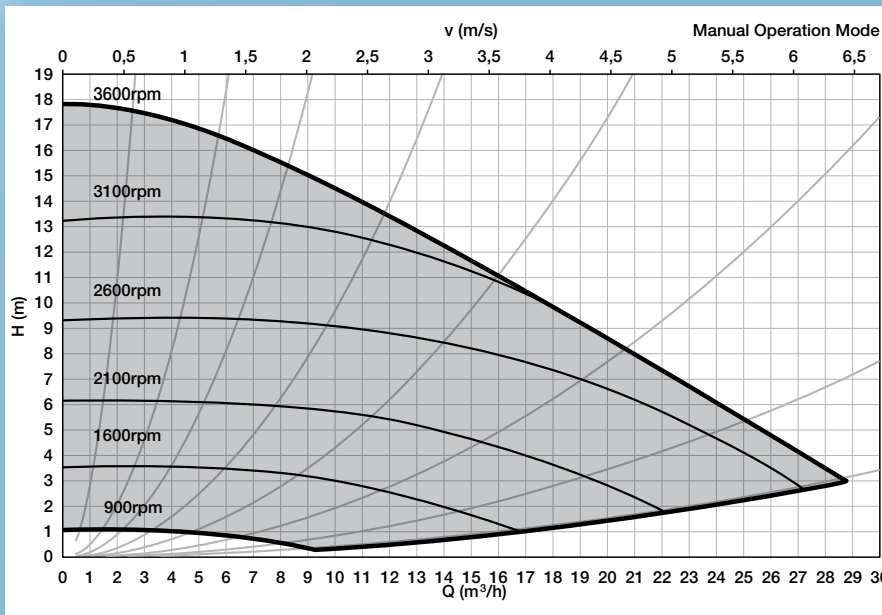
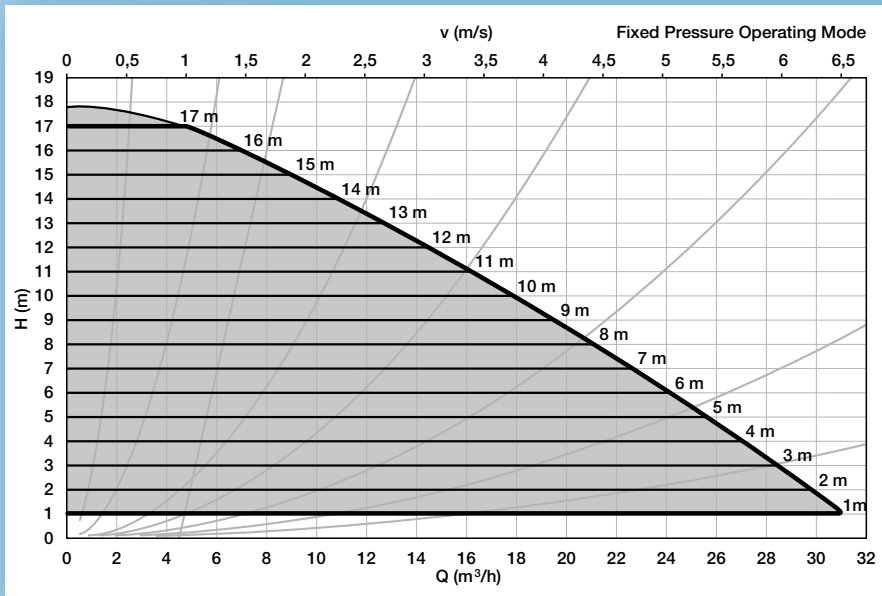
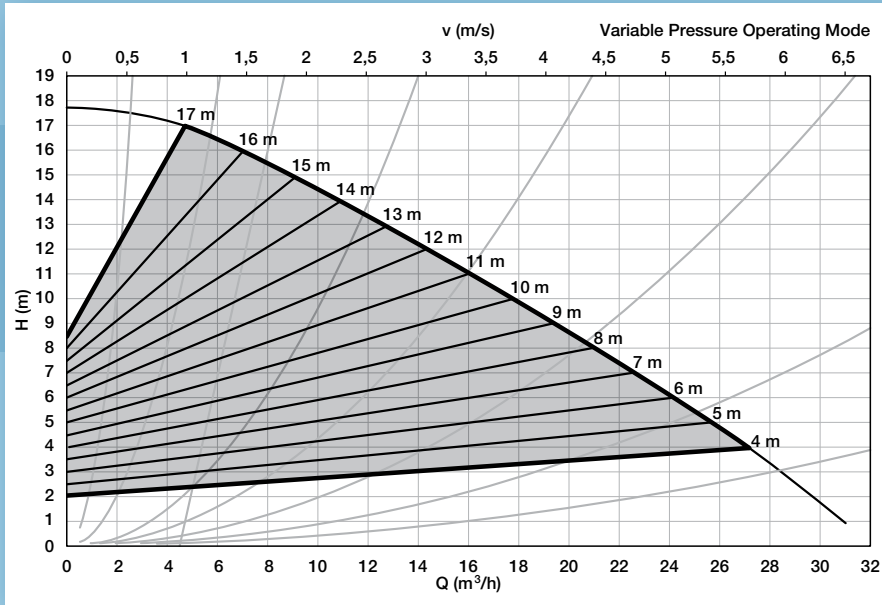



# OPTIMA 5/8



Maximum Pumping Height [m]	According to the pump type
Maximum Flow Rate [m <sup>3</sup> /h]	According to the pump type
Motor Speed [rpm]	1.400 – 4.800
Input Voltage and Frequency	1~ 230 V AC ± %10, 50 Hz, PE (ground protected)
Rated Current [A]	1,5
Power drawn [W]	10 – 350
Energy Efficiency Index (EEI)	< 0.23
Insulation Class	F
Protection Class	IP 44
Temperature Class	TF 110
Maximum System Pressure	PN 6/10 <sup>(1)</sup>
Sound Pressure	< 56 dB (depends on the type)
Relative Humidity	< 90%
Weight	12 kg

<sup>1</sup> Pump is suitable for use in both pressure values.

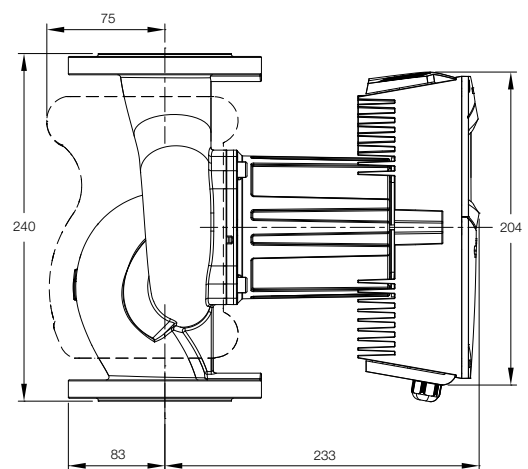
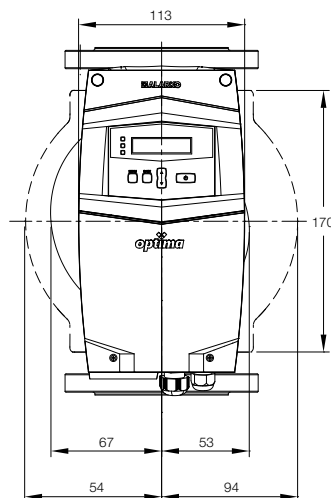
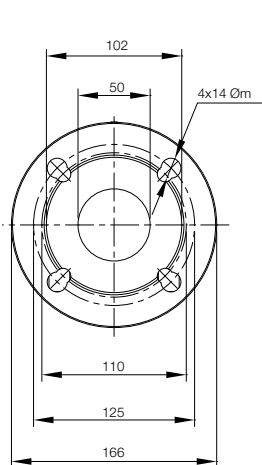



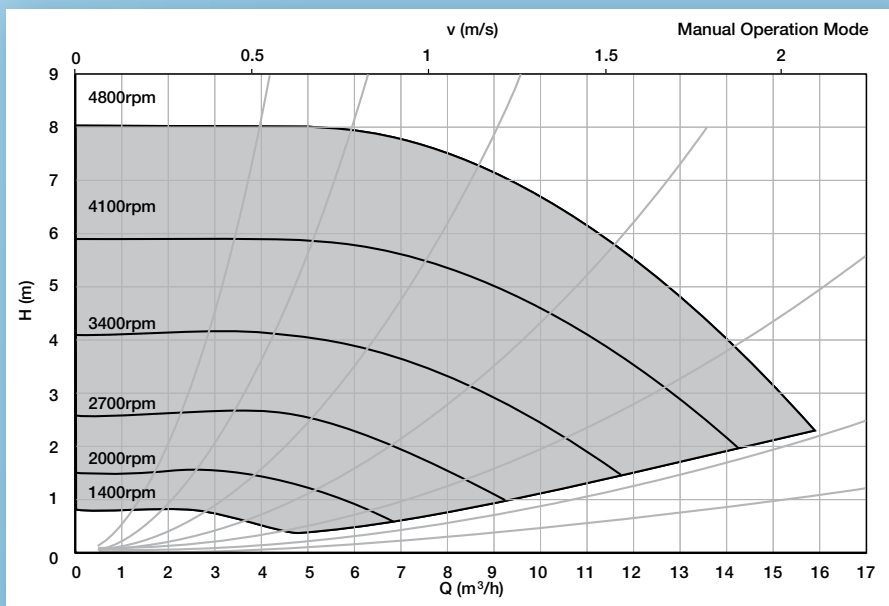
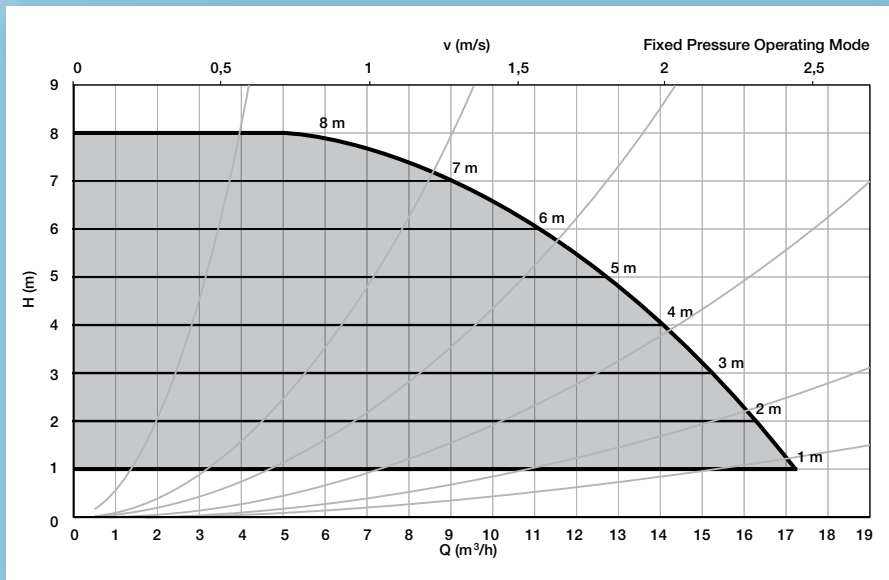
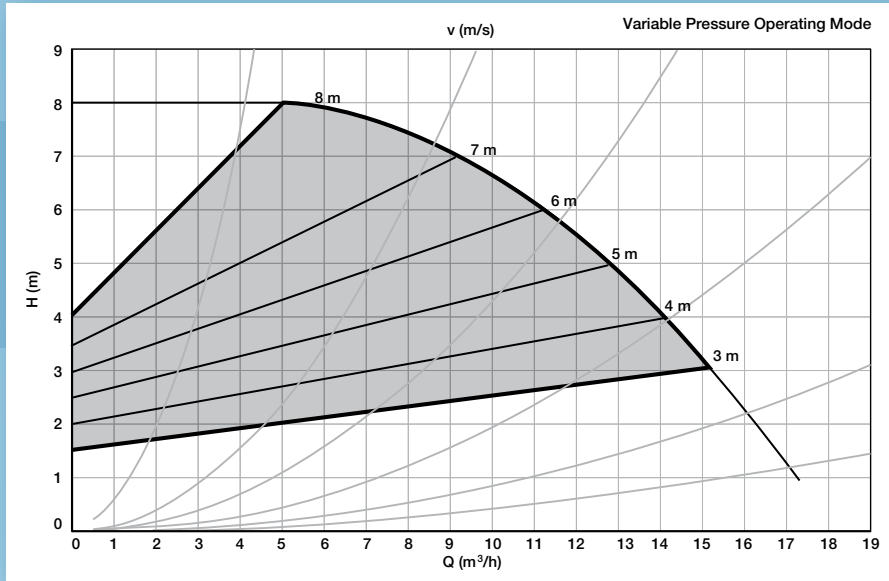



# OPTIMA 5/9



Maximum Pumping Height [m]	According to the pump type
Maximum Flow Rate [m <sup>3</sup> /h]	According to the pump type
Motor Speed [rpm]	1.400 – 4.100
Input Voltage and Frequency	1~ 230 V AC ± %10, 50 Hz, PE (ground protected)
Rated Current [A]	2,3
Power drawn [W]	40 – 505
Energy Efficiency Index (EEI)	< 0.23
Insulation Class	F
Protection Class	IP 44
Temperature Class	TF 110
Maximum System Pressure	PN 6/10 <sup>(1)</sup>
Sound Pressure	< 56 dB (depends on the type)
Relative Humidity	< 90%
Weight	15 kg

<sup>1</sup> Pump is suitable for use in both pressure values.

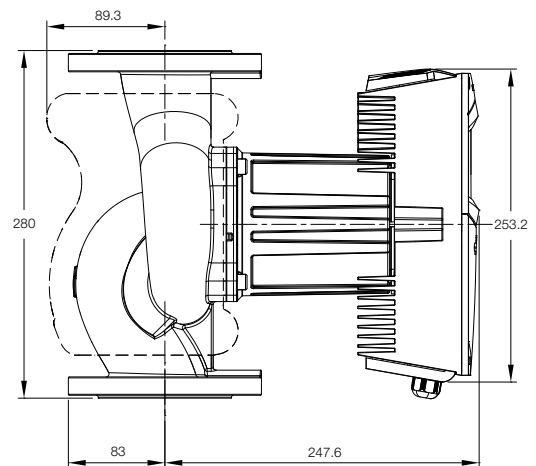
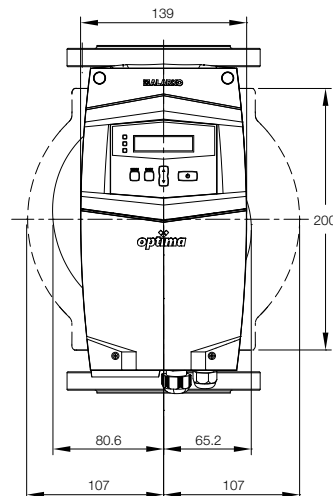
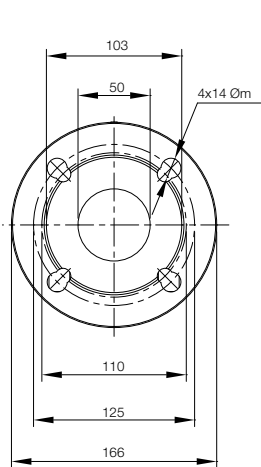

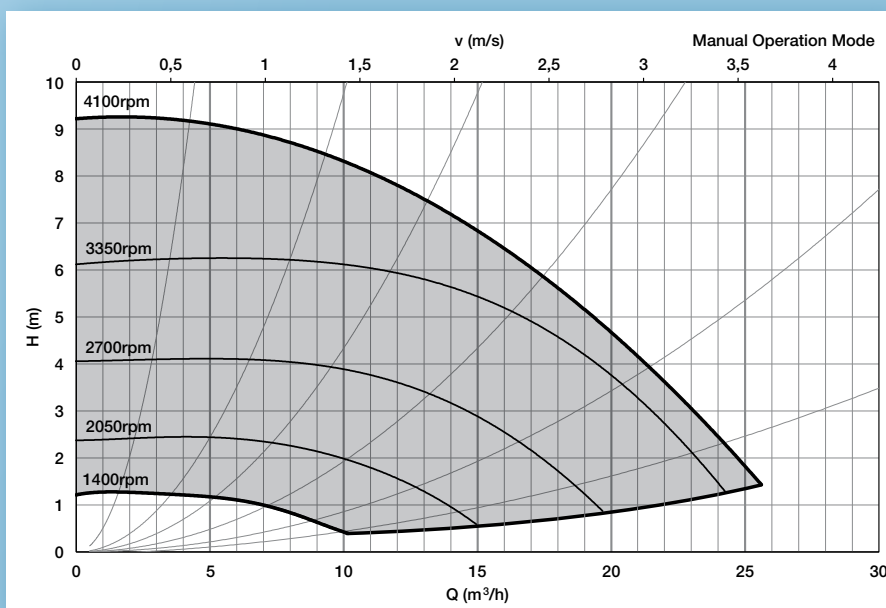
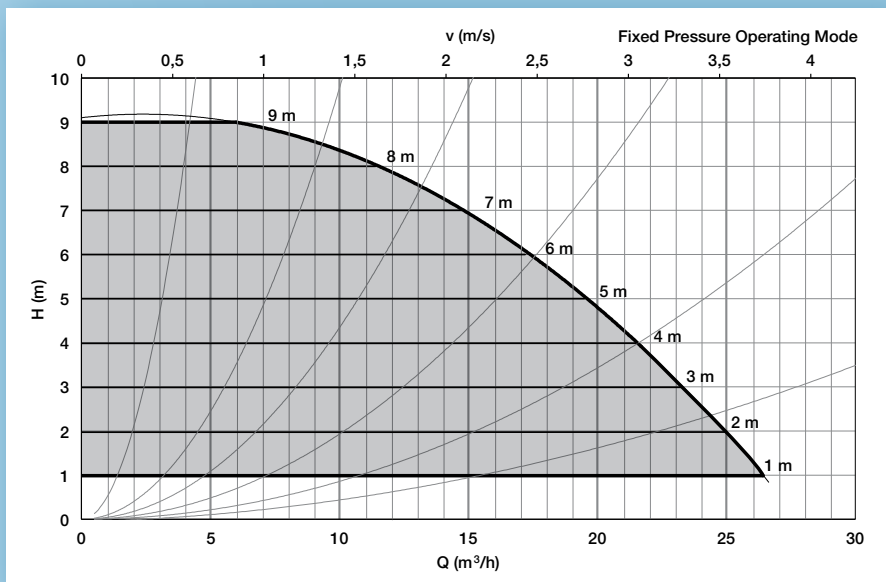
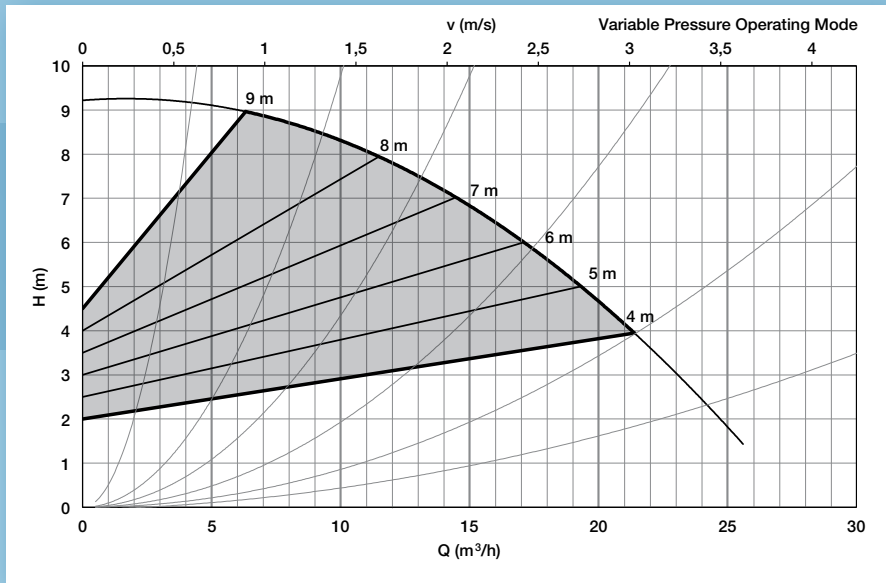





# OPTIMA 5/12



Maximum Pumping Height [m]	According to the pump type
Maximum Flow Rate [m <sup>3</sup> /h]	According to the pump type
Motor Speed [rpm]	1.400 – 4.600
Input Voltage and Frequency	1~ 230 V AC ± %10, 50 Hz, PE (ground protected)
Rated Current [A]	3,3
Power drawn [W]	26 – 730
Energy Efficiency Index (EEI)	< 0.23
Insulation Class	F
Protection Class	IP 44
Temperature Class	TF 110
Maximum System Pressure	PN 6/10 <sup>(1)</sup>
Sound Pressure	< 56 dB (depends on the type)
Relative Humidity	< 90%
Weight	15 kg

<sup>1</sup> Pump is suitable for use in both pressure values.

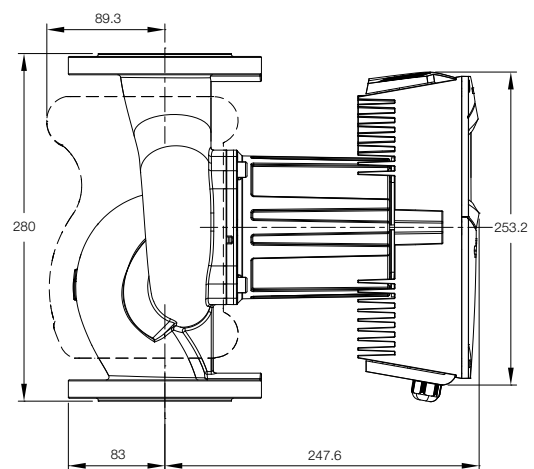
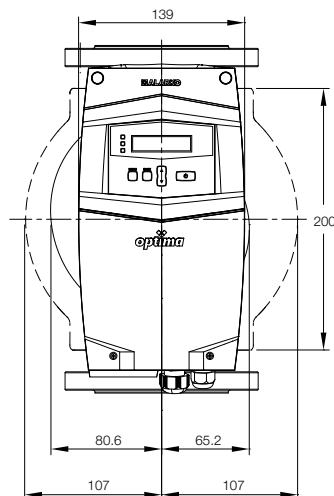
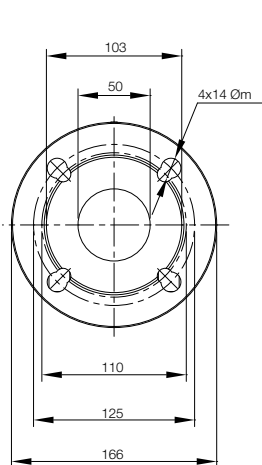

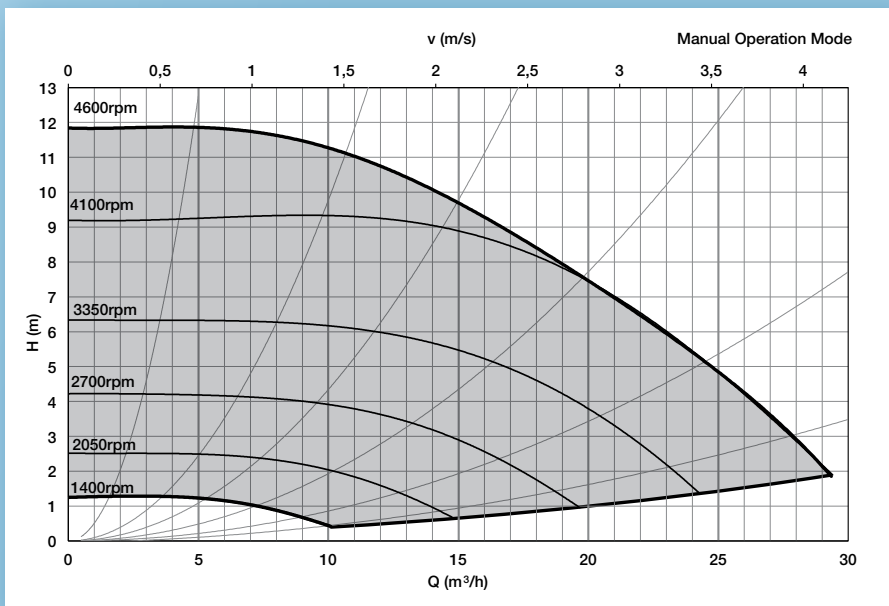
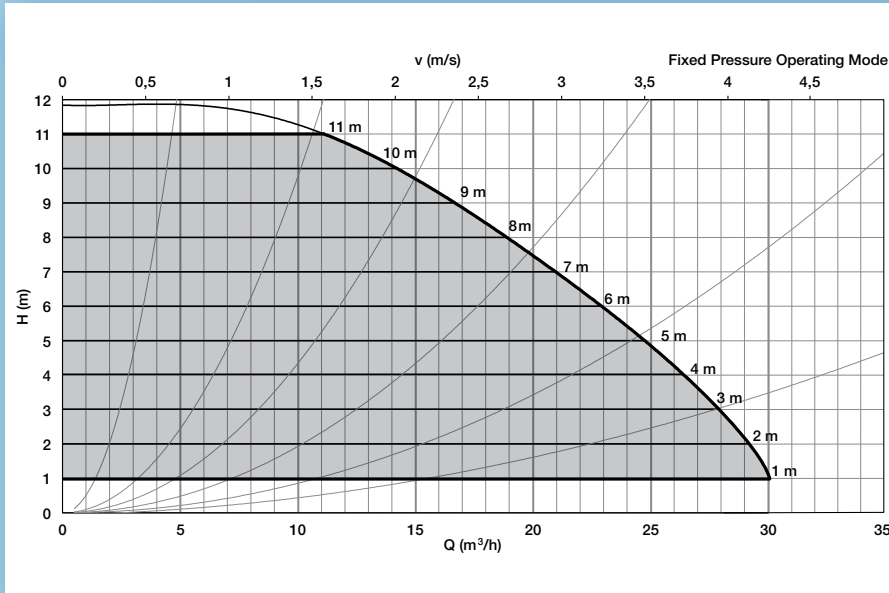
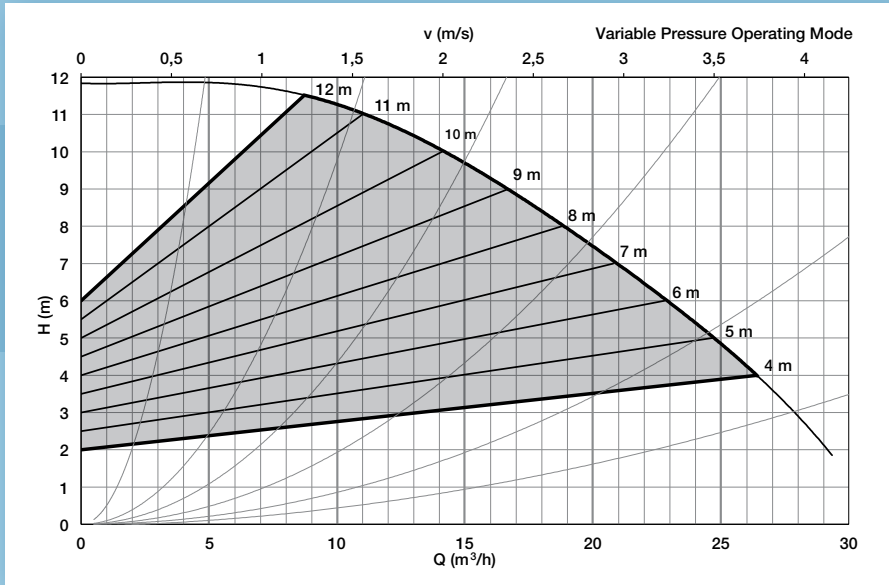



# OPTIMA 5/18



Maximum Pumping Height [m]	According to the pump type
Maximum Flow Rate [m <sup>3</sup> /h]	According to the pump type
Motor Speed [rpm]	900 – 3.500
Input Voltage and Frequency	1~ 230 V AC ± %10, 50 Hz, PE (ground protected)
Rated Current [A]	5,9
Power drawn [W]	36 – 1310
Energy Efficiency Index (EEI)	< 0.23
Insulation Class	F
Protection Class	IP 44
Temperature Class	TF 110
Maximum System Pressure	PN 6/10 <sup>(1)</sup>
Sound Pressure	< 56 dB (depends on the type)
Relative Humidity	< 90%
Weight	25.8 kg

<sup>1</sup> Pump is suitable for use in both pressure values.

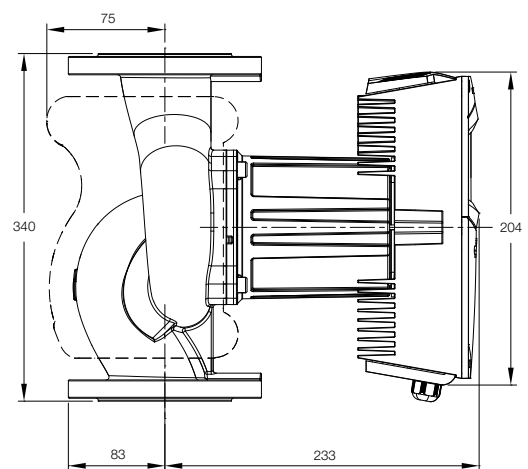
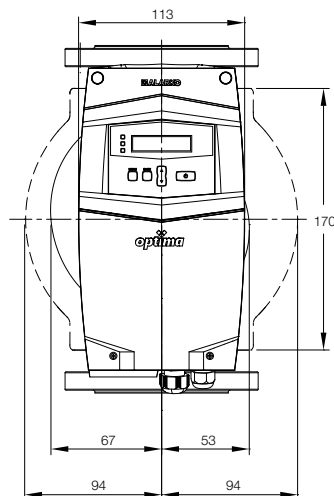
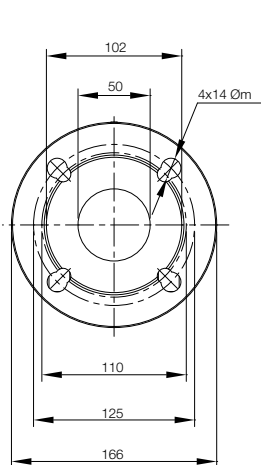



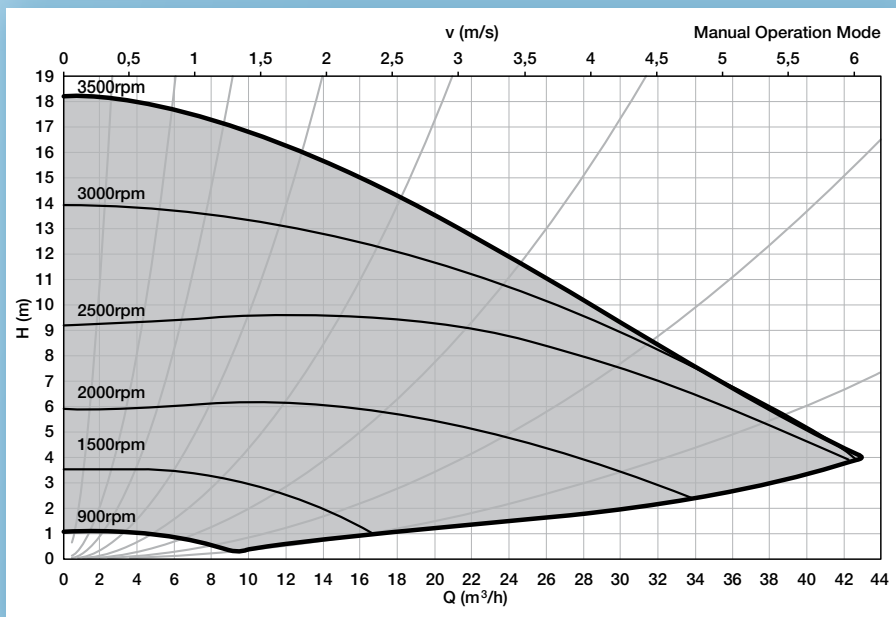
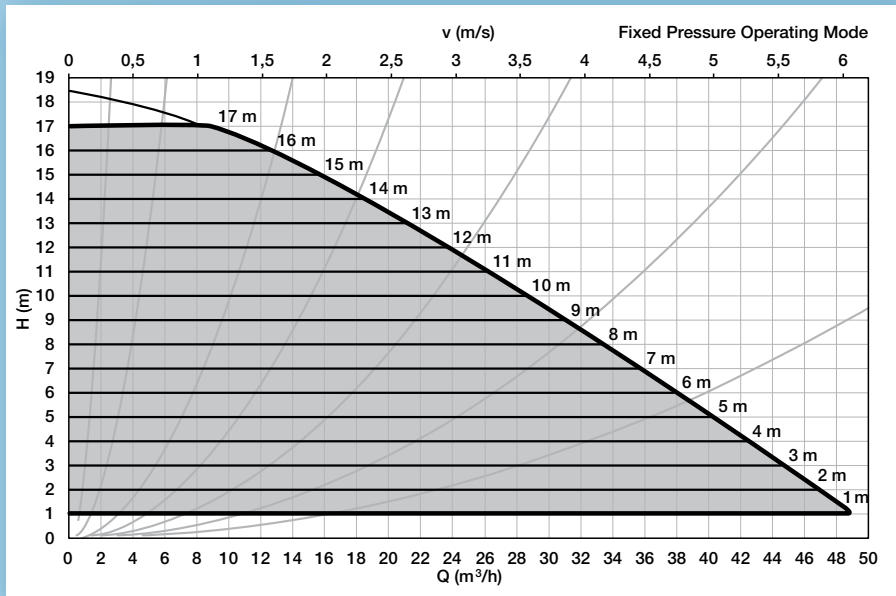
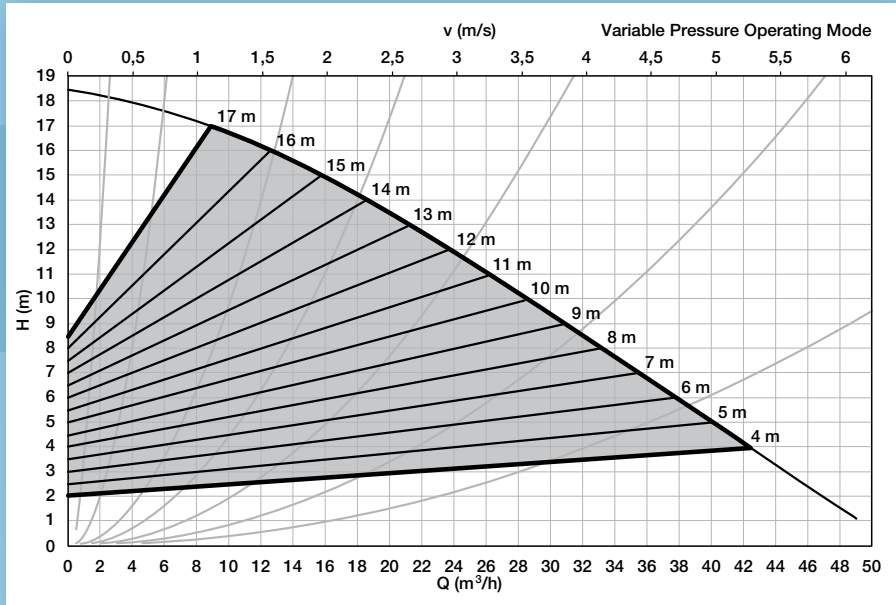



# OPTIMA 6/9



Maximum Pumping Height [m]	According to the pump type
Maximum Flow Rate [m <sup>3</sup> /h]	According to the pump type
Motor Speed [rpm]	1.400 – 4.400
Input Voltage and Frequency	1~ 230 V AC $\pm$ %10, 50 Hz, PE (ground protected)
Rated Current [A]	2,9
Power drawn [W]	23 – 640
Energy Efficiency Index (EEI)	< 0.23
Insulation Class	F
Protection Class	IP 44
Temperature Class	TF 110
Maximum System Pressure	PN 6/10 <sup>(1)</sup>
Sound Pressure	< 56 dB (depends on the type)
Relative Humidity	< 90%
Weight	16,8 kg

<sup>1</sup> Pompa her iki basınç değerinde de kullanıma uygundur.

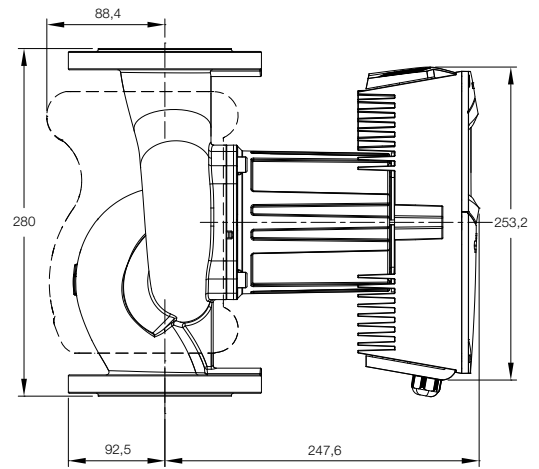
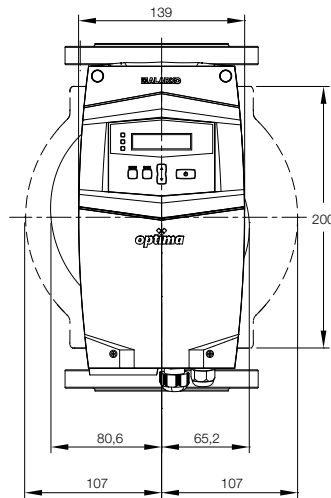
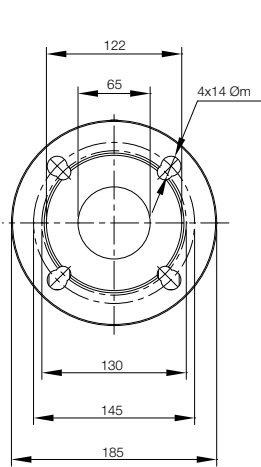

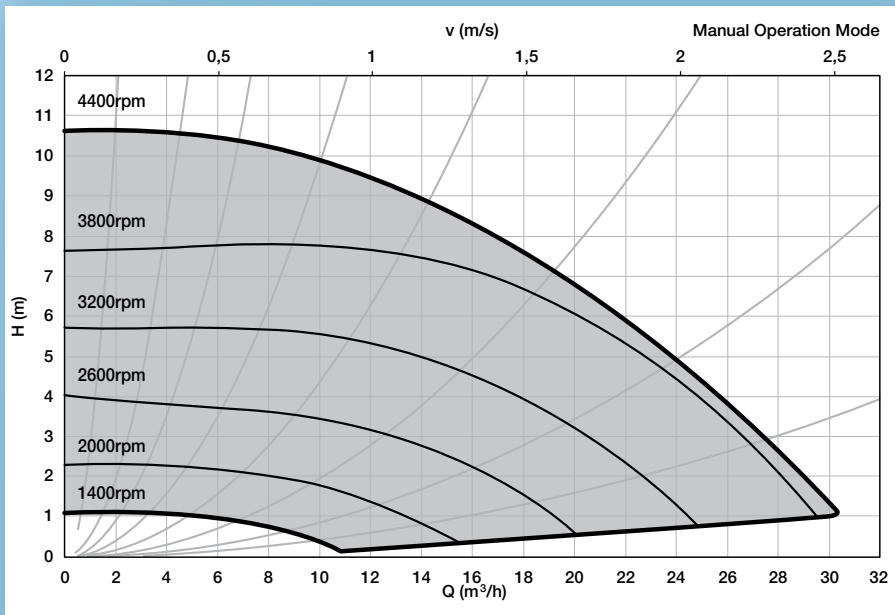
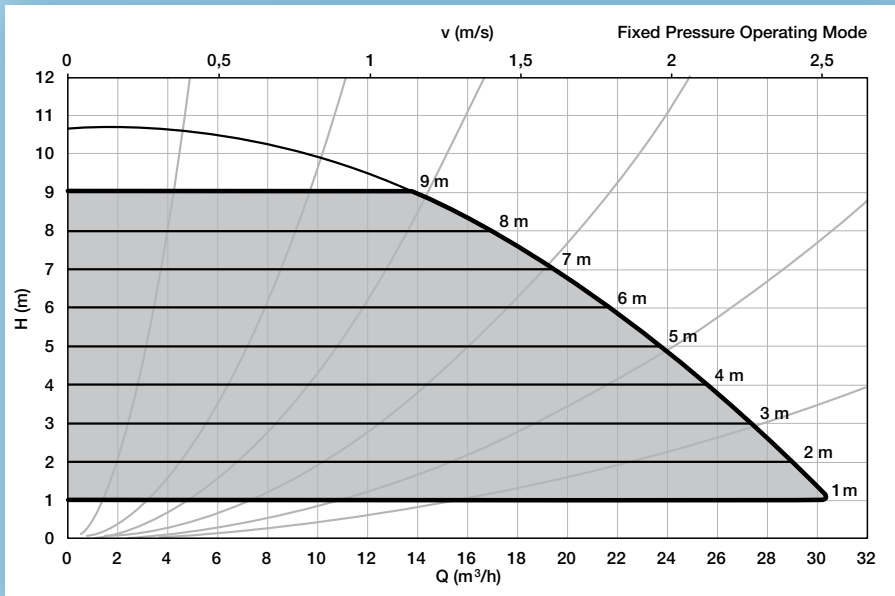
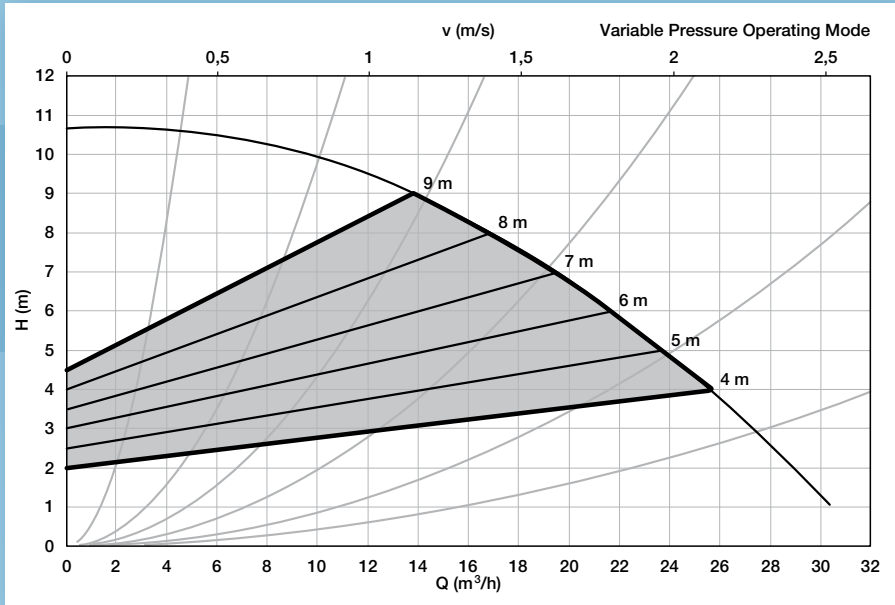



# OPTIMA 6/12



Maximum Pumping Height [m]	According to the pump type
Maximum Flow Rate [m <sup>3</sup> /h]	According to the pump type
Motor Speed [rpm]	900 – 3.300
Input Voltage and Frequency	1~ 230 V AC ± %10, 50 Hz, PE (ground protected)
Rated Current [A]	4,5
Power drawn [W]	30 – 1000
Energy Efficiency Index (EEI)	< 0.23
Insulation Class	F
Protection Class	IP 44
Temperature Class	TF 110
Maximum System Pressure	PN 6/10 <sup>(1)</sup>
Sound Pressure	< 56 dB (depends on the type)
Relative Humidity	< 90%
Weight	28 kg

<sup>1</sup> Pump is suitable for use in both pressure values.

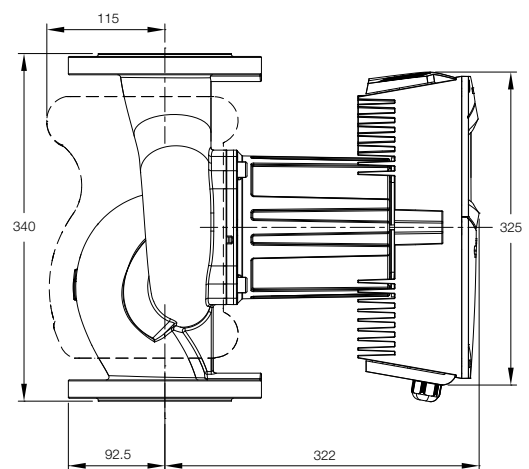
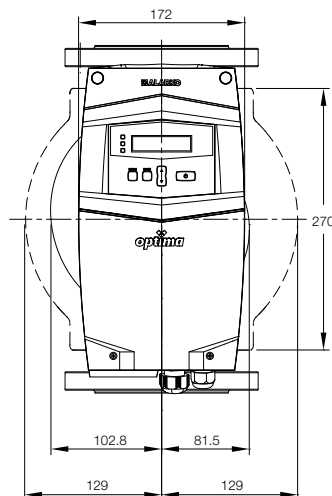
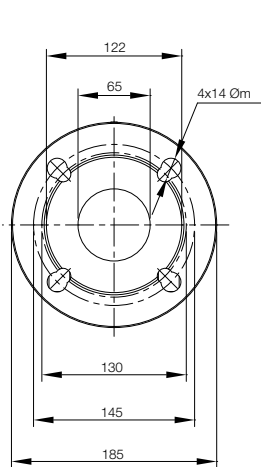



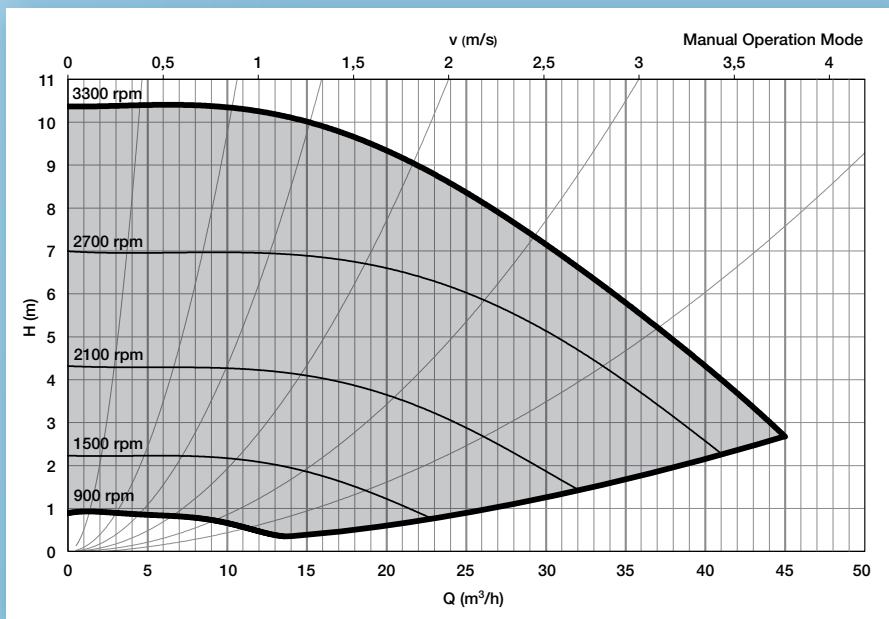
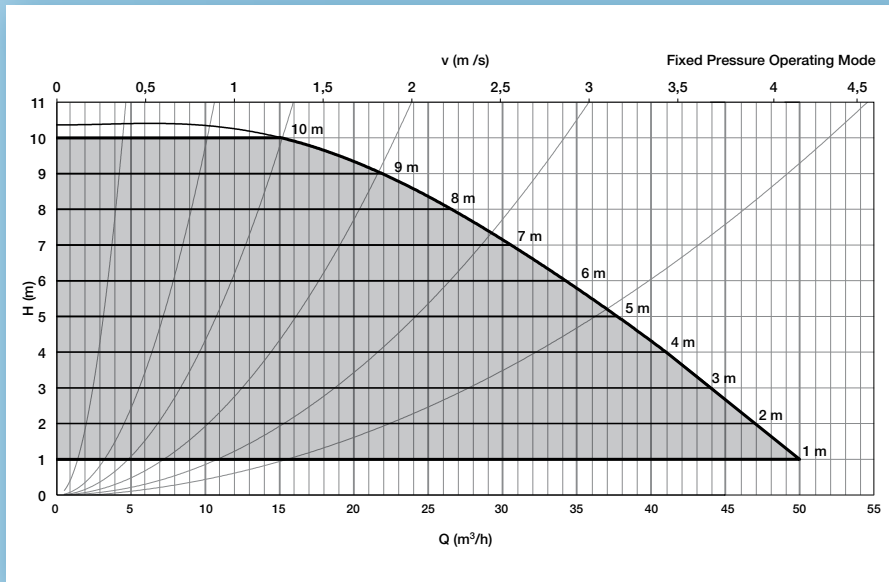
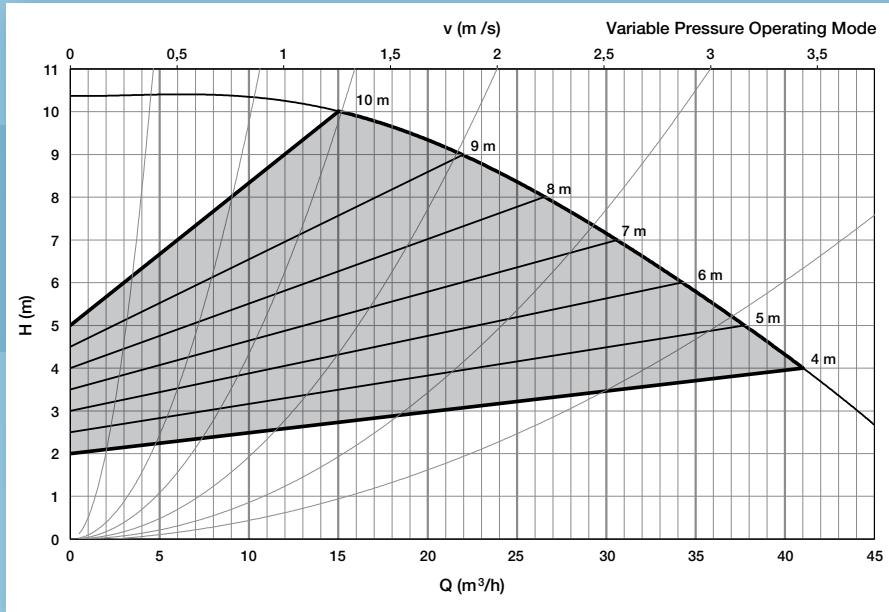



# OPTIMA 8/12



Maximum Pumping Height [m]	According to the pump type
Maximum Flow Rate [m <sup>3</sup> /h]	According to the pump type
Motor Speed [rpm]	900 – 3.300
Input Voltage and Frequency	1~ 230 V AC ± %10, 50 Hz, PE (ground protected)
Rated Current [A]	7
Power drawn [W]	40 – 1.540
Energy Efficiency Index (EEI)	< 0.23
Insulation Class	F
Protection Class	IP 44
Temperature Class	TF 110
Maximum System Pressure	PN 6 veya PN 10 <sup>(1)</sup>
Sound Pressure	< 56 dB (depends on the type)
Relative Humidity	< 90%
Weight	31 kg

<sup>1</sup> Different pumps are available for different pressure values.

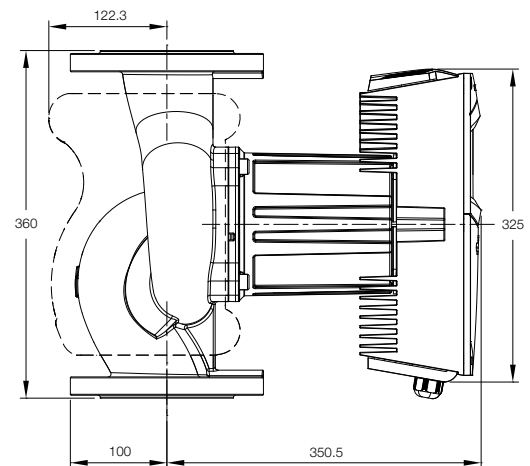
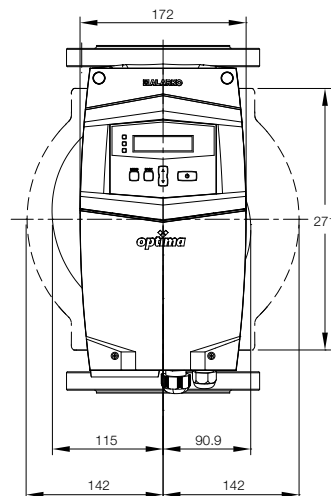
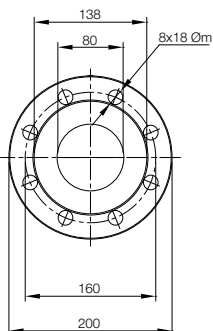
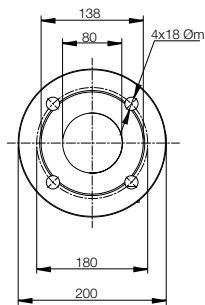

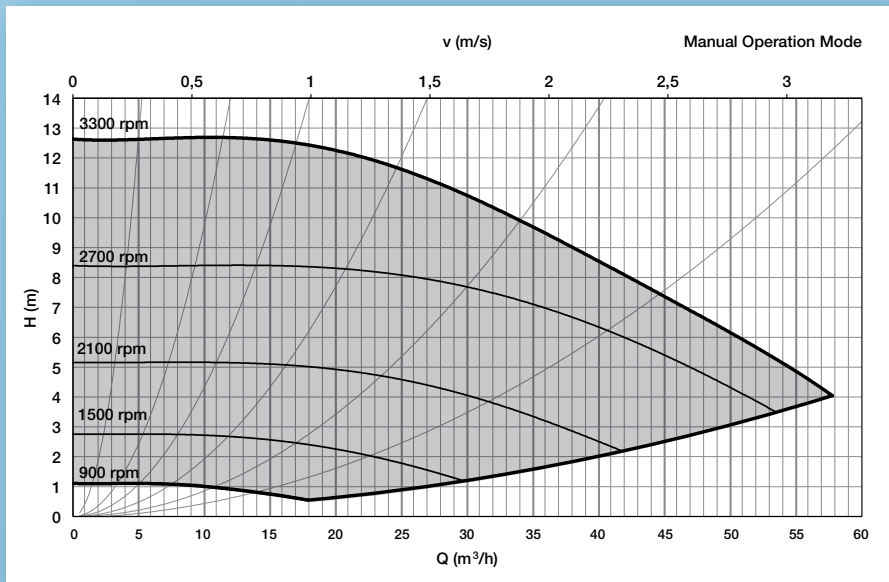
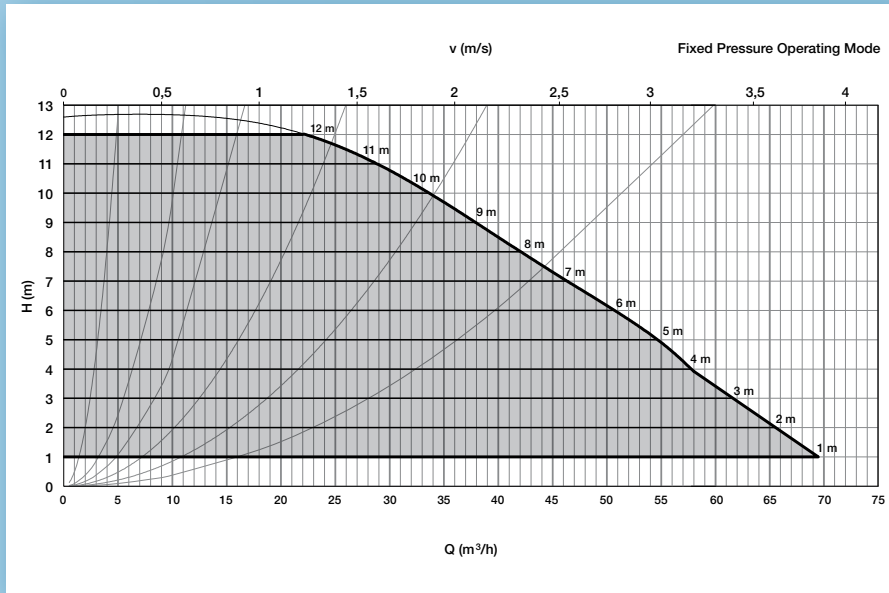
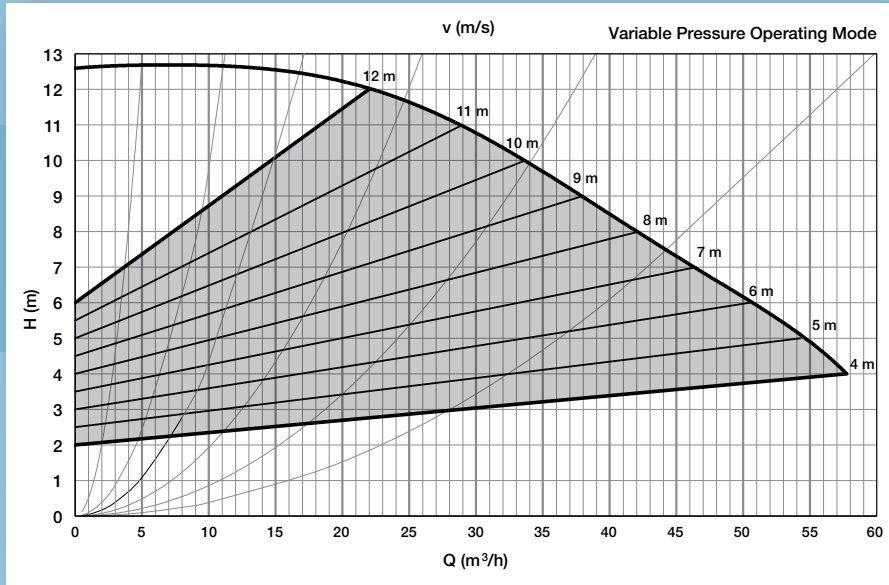



## MODE OPTIONS TABLE

	Variable Pressure	Constant Pressure
<p><b>Heating Systems with Two Pipes and Thermostatic Valve</b></p>		
<p><b>Heating Systems with Single Pipe</b></p>	<ul style="list-style-type: none"> <li>Total friction loss &gt; 4mSS</li> <li>Extremely long circulation line</li> <li>High friction loss</li> <li>Pressure stabilizing valve use</li> <li>Excessively tightened branch valves</li> </ul>	<ul style="list-style-type: none"> <li>Total friction loss &lt; 2mSS</li> <li>Short and large diameter circulation lines</li> <li>Low friction loss</li> </ul>
<p><b>Underfloor Heating Systems</b></p>	<ul style="list-style-type: none"> <li>High friction loss</li> <li>Pressure stabilizing valve use</li> </ul>	<ul style="list-style-type: none"> <li>Systems with thermostatic valve</li> <li>Systems with thermostatic valve and pressure stabilizing valve</li> </ul>
<p><b>Heating Systems with Condensing Boiler</b></p>	<ul style="list-style-type: none"> <li>Secondary circulation circuit</li> <li>High friction loss</li> <li>Pressure stabilizing valve use</li> </ul>	<ul style="list-style-type: none"> <li>Primary circulation circuit</li> <li>Low pressure loss</li> <li>Natural circulation</li> </ul>

## POWER CABLE OPTIONS TABLE

NOMINAL VOLTAGE	Motor Power		Cable Section (mm <sup>2</sup> )				
	kW	HP	4x1.5	4x2.5	4x4	4x6	4x10
MONOPHASE 220 V	0,37	0,5	80	133	212	316	520
	0,55	0,75	58	95	150	226	372
	0,75	1	42	69	110	164	271
	1,1	1,5	35	55	91	136	164
	1,5	2	25	41	66	98	121

Note: Manufacturer reserves the right to change any product specifications without notice.

**ALARKO**



**ALARKO CARRIER  
SANAYİ VE TİCARET A.Ş.**

GOSB - Gebze Organize Sanayi Bölgesi, Şahabettin Bilgisu Cad.

No:1604 Gebze 41480 KOCAELİ - TÜRKİYE

Phone: +90 262 648 60 00

Fax: +90262 648 60 08

[www.alarko-carrier.com.tr](http://www.alarko-carrier.com.tr)

[info@alarko-carrier.com.tr](mailto:info@alarko-carrier.com.tr)