

## Domestic Spherical Boosters AKH 60-80 MNF Series

Alarko automatic domestic spherical booster pump is the ideal solution for pressurized water supply where the mains pressure is insufficient. It is extremely quiet and smooth, so it can even be used in the apartment. Alarko booster pumps have a system that allows the booster to operate automatically according to pressure changes in the installation.

- These are plug-and-play compact booster systems specially designed for places such as houses, villas, small buildings, farms, small workplaces, kiosks, etc.
- Fully automatic package system with water tank, pump, pressure switch, manometer and check valve.
- Can be operated in single-phase mains.
- Suction feature up to 9 meters from open wells and self-framed.
- Can run above the water tank.
- Superior booster pump with bronze fan and graphite/ceramic packing.

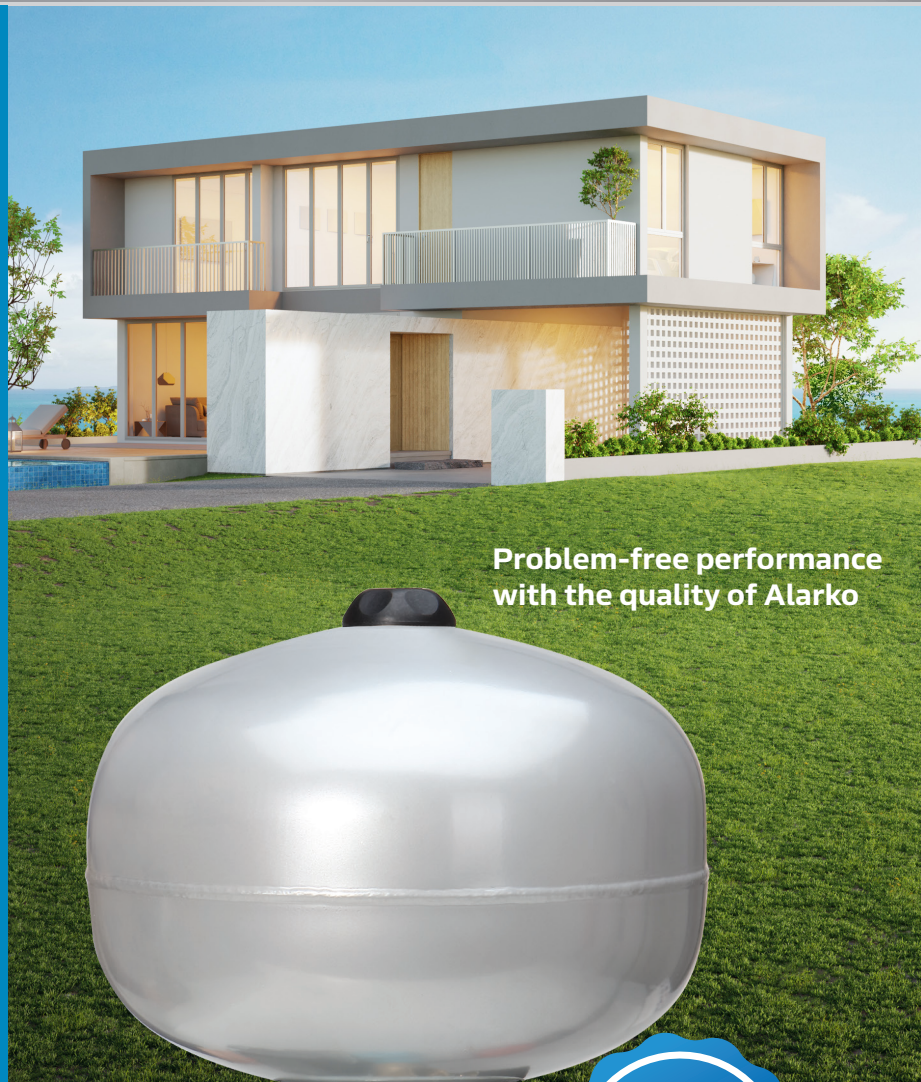

Problem-free performance  
with the quality of Alarko

**SMALL SIZE, COMPACT DESIGN  
THAT TAKES UP NO SPACE**

Quiet  
Operation,  
Easy to  
Assemble.



## Performance Curves and Tables

TYPE	POWER	CAPACITY	WATER CONNECTION		TANK VOLUME	VOLTAGE	Hmax	Qmax (m³/h)	PRESSURE RANGE	FLOW RATE RANGE	WEIGHT
	HP	Floor/Apartment	(Input)	(Output)	(LT)	(V)	(mSS)	m³/h	(mSS)	m³/h	(kg)
AKH 60	0,5	-	1"	1"	24	230	40	2,4	0,5 - 40	0 - 2,4	11
AKH 80	1	-	1"	1"	24	230	65	3,3	0,5 - 65	0 - 3,3	15

MAIN PARTS and STRUCTURAL CHARACTERISTICS	AKH 60	AKH 80
Pump Housing		Casting
Pump Shaft		Stainless Steel
Motor Casing		Aluminum Extr.
Fan		Bronz
Diffuser		Casting
Mechanical Seal		Graphite/Ceramic
Insulation Class		F
Protection Class		IP4X
Max Suction Height		5 mt
Max. Operating Temperature		35 °C
Max Environmental Temperature		40 °C

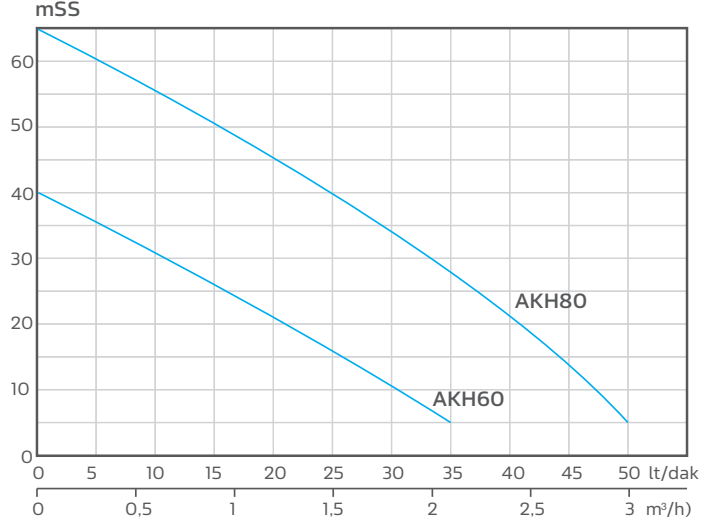

TYPE	Dimensions (mm)				
	A	Width	X1	X2	Y
AKH 60	400	400	120	198	580
AKH 80	400	400	150	230	600

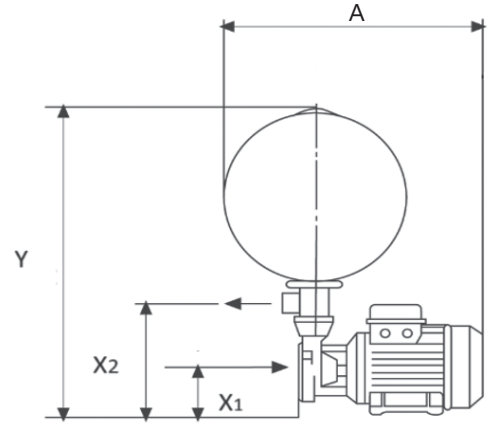

COMMON FEATURES												
CAPACITY	AKH 60						AKH 80					
m³/h	0	0,3	0,6	0,9	1,2	1,5	1,8	2,1	2,4	2,7	3	
lt/dk	0	5	10	15	20	25	30	35	40	45	50	
Hm (mSS) (QBm60)	40	35	31	26	21	16	11	5	*	*	*	
Hm (mSS) (QBm80)	65	60	55	50	45	40	34	28	21	13	5	

Note: Manufacturer reserves the right to change any product specifications without notice.