



Dalgıç Pompalar AL 6"-7"-8" KPS Serisi



SUYA HAYAT VEREN TEKNOLOJİ





Alarko dalgıç pompaları kullanım ve içme suyu alanında

- Her an kullanıma hazır
- Dertsiz
- Yatırımı kısa sürede geri ödeyen

**KESİNTİSİZ, KİŞİSEL
TEK SU KAYNAĞIDIR**



Alarko dalgıç pompaları müstakil evlerden gökdelenlere kadar tüm binalarda çeşitli amaçlarla kullanım suyu depolanmasında hidrofor gibi kullanılmalarının da sağladığı üstünlükle

ÇOK İŞLEVSELDİR

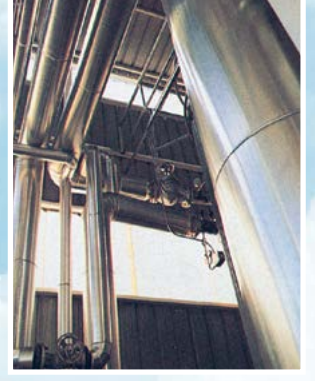

Alarko dalgıç pompaları endüstriyel tesis ve işletmelerde proses ve kullanım suyu sağlanmasında

- Yüksek verimi,
- Uzun ömrü ile

**UYGUN BİR
YATIRIMDIR**

**ALARKO,
DALGIÇ POMPADA
HER ZAMAN**



Alarko dalgıç pompaları bahçecilik ve tarım alanında, küçük bir ev bahçesinden, on binlerce dönüm tarım arazisinin sulanmasında bahçeseverlerin ve çiftçilerin

**GÜVENİLİR BİR
DOSTUDUR**



Alarko dalgıç pompaları özellikle turizm mevsiminde suya her zamankinden fazla ihtiyaç duyulan turistik tesislerde

**GÜVENİLİR TEK
SU KAYNAĞIDIR**



Alarko dalgıç pompaları
• Üstün teknolojisi
• Ekonomikliği
• Sürekli ve kaliteli hizmeti
• Yedek parçada hızlı temin sistemi ile

RAKİPSİZDİR

NUMARA



AVANTAJLARI

- Motor yukarıda olmadığı için açık hava şartlarından korunması gerekmez.
- Özel boru ve aksam gerektirmez.
- Fan ayarlama sorunu yoktur.
- Yağsız kalma sorunu yaşanmaz.
- Montajı kolaydır, eksenleme problemi yoktur.
- Sessizdir.
- Kuyulardaki eğilimlerden dik milli pompalar kadar etkilenmez.
- 50 Hp motor gücüne kadar 60 m³/h debi için 8" yerine 6 5/8", 125 m³/h debi için 10 3/4" yerine 8 5/8" sondaj borusu kullanma imkanı.

UYGULAMA VERİLERİ

- Su yağlamalı 10-250 HP arasındaki güçlerde üç fazlı sincap kafesli asenkron motorlar.
- Özel izoleli, su içinde çalışmaya uygun bobin teli kullanılan stator.
- Su ile yağlamalı radyal yatak ve aksiyal yükü taşıyan aksiyal yatak grubu.
- Su altında çalışmaya uygun, özel olarak dizayn edilmiş, standart boyda kesilmiş yassı motor çıkış kablosu.
- 20 HP'ye kadar direkt, 25-250 HP arası yıldız üçgen yol vermeli.
- AL 6"-7"-8" motorlarda soft starter (yumuşak yol verme) ile farklı frekans ve gerilim değerleri için çalıştırmaya uygun opsiyonel tasarım.
- Su seviye rölesi ile kuyu suyu seviyesine göre otomatik olarak pompanın devreye giriş çıkış kontrolü.
- Faz kontrol rölesi ile motoru, iki faz çalışmaya ve faz dengesizliklerine karşı koruma.

TASARIM

Tüm Alarko 6", 7" ve 8" KPS dalgıç pompaları AISI 304 (DIN W.-Nr.1.4301) paslanmaz çelikten imal edilmiştir. Agrasif aşındırıcılığı daha yüksek sular için AISI 316 (DIN W.-Nr.1.4401) paslanmaz çelikten opsiyonel üretim imkanı vardır. Sekizgen biçimli kauçuk yataklar ve kum kanalları ile kum pompalanan kuyu suyu ile pompadan uzaklaştırılır.

UYGULAMA LİMİTLERİ

- Pompa anma çaplarına göre: 6", 7" ve 8"lik üç seri.
- 10-250 HP arasında toplam 10 tipte, 232 model.

GENEL SEÇİM ABAĞI

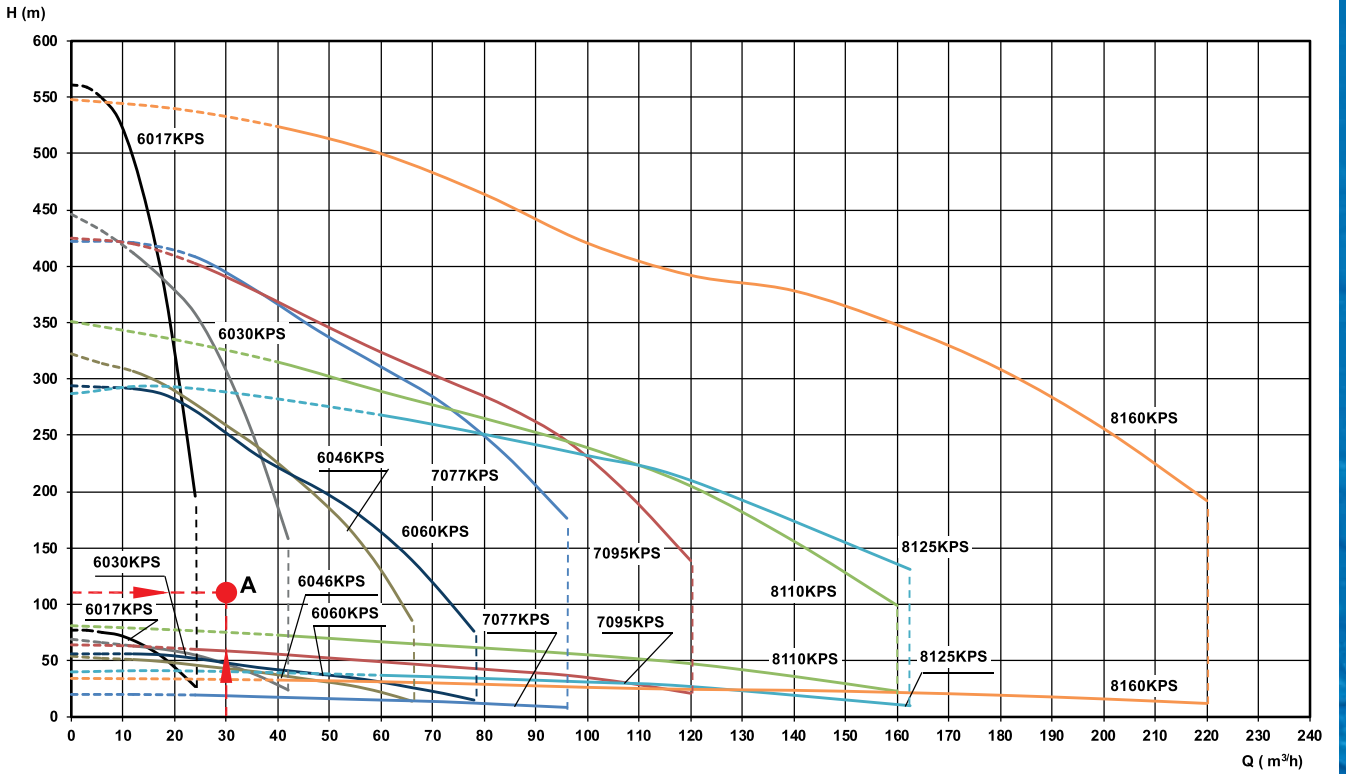

POMPA SEÇİMİ

“Genel Seçim Abağı”ndan istenilen debi ve manometrik yüksekliğin kesişme noktasının (A) hangi pompa tipine ait bölgede kaldığı belirlenir. Pompayı seçebilmek için belirlenen pompanın “Bağımsız Karakteristik Eğrisi”ne bakılır. Debi, manometrik yüksekliğin kesişme noktasına üstten en yakın eğri üzerindeki kademe sayısı okunur. Bulunan pompa tipi ve kademesine göre “Elektriksel Özellikler, Boyutlar ve Ağırlıklar Tablosu”ndan motor tipi ve gücü belirlenir. Elektrik kumanda panosu talebi ve elektrik kablosunun uzunluğunu da belirterek, “Sipariş Notasyonu”na göre pompa, Alarko Carrier bayisinden talep edilir.

SEÇİM ÖRNEĞİ

Kuyu çapı 8^{5/8"}, debi (Q) 46 m³/saat ve manometrik yükseklik (H) 125 mSS olsun. “Genel Seçim Abağı”nda yatay eksen üzerinde 46 m³/saat ile dikey eksen üzerinde 125 mSS noktaları kesiştirilir. Kesişme noktası (A), 6046 KPS tipi pompa bölgesinde kalır. Buradan 6046 tipi pompa “Bağımsız Karakteristik Eğrisi”ne geçilir. 46 m³/saat ve 125 mSS noktalarının kesişme noktası 15. kademe eğrisi üzerindedir. Pompa kademesi 15. olarak seçilir. Pompa verimi % 74’tür. “Elektriksel Özellikler, Boyutlar ve Ağırlıklar Tablosu”ndan pompa tipi ve AL 6-30 olarak bulunur. Sipariş notasyonu 6046/15 KPS+AL 6-30 olarak belirlenir.

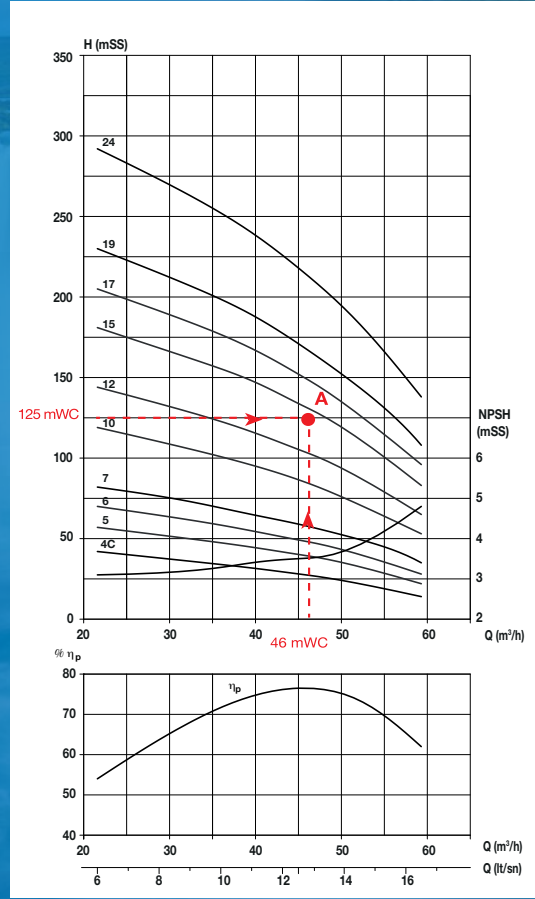

KABLO SEÇİMİ

Motor Gücü		Nominal Gerilim	Kablo Kesiti 3x.....(mm ²)																
			2,5	4	6	10	16	25	35	50	70	95	120	150	150				
KW	HP	3 Fazlı 380 V	Maksimum uzunluk (metre)																
4	5,5			110	170	260	450												
5,5	7,5		80	130	190	340	540												
7,5	10		60	100	150	250	410												
9,2	12,5		50	80	120	205	330	510											
11	15			60	100	170	280	440											
13	17,5				90	150	245	385											
15	20				80	130	210	330	460	660									
18,5	25			60	90	160	250	400	560										
22	30			50	70	130	210	340	470										
26	35			46	68	110	180	290	410										
30	40				60	100	160	250	360	500									
37	50				40	80	130	200	290	410									
45	60					70	110	170	240	350	480								
51	70						95	150	210	305	420								
55	75						80	130	180	260	360	500							
59	80							120	170	245	340	475							
66	90								110	160	230	320	450	520					
75	100									100	150	200	290	380	440	540	540		
81	110										135	185	260	340	405	495	495		
92	125										120	170	230	300	370	450	450		
110	150										100	140	200	250	300	370	370		
132	180											120	165	210	260	310	310		
150	200												150	190	230	280	280		
165	225													130	170	200	240	240	
185	250														125	160	190	230	230

25 HP ve üzeri motorlar yıldız üçgendir. Yıldız üçgen motorlarda, yukarıda belirtilen uzunluktaki kablolardan 2 adet kullanılmalıdır.

ELEKTRİKSEL ÖZELLİKLER, BOYUTLAR VE AĞIRLIKLAR

TİP Pompa + Motor		MOTOR GÜCÜ		MOTOR AKIMI (A)	BASMA BORUSU ÇAPI	POMPA+MOTOR BOYU (mm)	POMPA GÖVDE DIŞ ÇAPI (mm)	AĞIRLIK (Kg)	
		(HP)	(kW)						
ALK 6017 KPS / 7	+ ALK6-5,5	5,5	4	10	BSP G3	1386	149,5	55	
ALK 6017 KPS / 9	+ ALK6-7,5	7,5	5,5	13		1552		61	
ALK 6017 KPS / 12	+ ALK6-10	10	7,5	18		1778		70	
ALK 6017 KPS / 16	+ ALK6-12,5	12,5	9,2	21		2050		79	
ALK 6017 KPS / 20	+ ALK6-15	15	11	25		2322		86	
ALK 6017 KPS / 24	+ ALK6-17,5	17,5	13	31		2632		98	
ALK 6017 KPS / 27	+ ALK6-20	20	15	34,5		2836	106		
ALK 6017 KPS / 32	+ ALK6-25	25	18,5	42		3223	121		
ALK 6017 KPS / 39	+ ALK6-30	30	22	49,2		3692	135		
ALK 6017 KPS / 45	+ ALK6-35	35	26	58		4160	154		
ALK 6017 KPS / 51	+ ALK6-40	40	30	66		4633	173		
ALK 6030 KPS / 6	+ ALK6-7,5	7,5	5,5	13		BSP G3	1583	149,5	61
ALK 6030 KPS / 8	+ ALK6-10	10	7,5	18	1820		69		
ALK 6030 KPS / 11	+ ALK6-12,5	12,5	9,2	21	2138		78		
ALK 6030 KPS / 13	+ ALK6-15	15	11	25	2360		84		
ALK 6030 KPS / 15	+ ALK6-17,5	17,5	13	31	2602		94		
ALK 6030 KPS / 17	+ ALK6-20	20	15	34,5	2834		101		
ALK 6030 KPS / 21	+ ALK6-25	25	18,5	42	3303		117		
ALK 6030 KPS / 26	+ ALK6-30	30	22	49,2	3828		132		
ALK 6030 KPS / 30	+ ALK6-35	35	26	58	4317		150		
ALK 6030 KPS / 35	+ ALK6-40	40	30	66	4907		171		
ALK 6030 KPS / 39	+ ALK6-50	50	37	81	5381		188		
ALK 6046 KPS / 4C	+ ALK6-7,5	7,5	5,5	13	BSP G3		1459	149,5	60
ALK 6046 KPS / 5	+ ALK6-10	10	7,5	18		1617	67		
ALK 6046 KPS / 6	+ ALK6-12,5	12,5	9,2	21		1760	73		
ALK 6046 KPS / 7	+ ALK6-15	15	11	25		1903	78		
ALK 6046 KPS / 8	+ ALK6-17,5	17,5	13	31		2066	87		
ALK 6046 KPS / 10	+ ALK6-20	20	15	34,5		2332	96		
ALK 6046 KPS / 12	+ ALK6-25	25	18,5	42		2643	110		
ALK 6046 KPS / 15	+ ALK6-30	30	22	49,2		3027	122		
ALK 6046 KPS / 17	+ ALK6-35	35	26	58		3358	138		
ALK 6046 KPS / 19	+ ALK6-40	40	30	66		3694	154		
ALK 6046 KPS / 24	+ ALK6-50	50	37	81		4349	177		
ALK 6060 KPS / 4	+ ALK6-10	10	7,5	18		BSP G4	1504	149,5	69
ALK 6060 KPS / 5	+ ALK6-12,5	12,5	9,2	21	1647		76		
ALK 6060 KPS / 6	+ ALK6-15	15	11	25	1790		81		
ALK 6060 KPS / 7	+ ALK6-17,5	17,5	13	31	1953		91		
ALK 6060 KPS / 8	+ ALK6-20	20	15	34,5	2106		99		
ALK 6060 KPS / 10	+ ALK6-25	25	18,5	42	2417		115		
ALK 6060 KPS / 12	+ ALK6-30	30	22	49,2	2688		126		
ALK 6060 KPS / 15	+ ALK6-35	35	26	58	3132		148		
ALK 6060 KPS / 17	+ ALK6-40	40	30	66	3468		166		
ALK 6060 KPS / 21	+ ALK6-50	50	37	81	4010		190		
ALK 7077 KPS / 1	+ ALK6-7,5	7,5	5,5	13	BSP G5		1284	172	69
ALK 7077 KPS / 2	+ ALK6-10	10	7,5	18			1457		78
ALK 7077 KPS / 3	+ ALK6-15	15	11	25		1645	87		
ALK 7077 KPS / 4	+ ALK6-20	20	15	34,5		1863	101		
ALK 7077 KPS / 5	+ ALK6-25	25	18,5	42		2076	113		
ALK 7077 KPS / 6	+ ALK6-30	30	22	49,2		2249	122		
ALK 7077 KPS / 7	+ ALK6-35	35	26	58		2482	136		
ALK 7077 KPS / 9	+ ALK6-40	40	30	66		2848	155		
ALK 7077 KPS / 11	+ ALK6-50	50	37	81		3194	172		
ALK 7077 KPS / 12	+ ALK7-60	60	45	91		3099	187		
ALK 7077 KPS / 15	+ ALK7-80	80	59	119		3669	224		
ALK 7077 KPS / 18	+ ALK8-85	85	63	126		3980	251		
ALK 7077 KPS / 21	+ ALK8-100	100	75	147	4504	290			

TİP Pompa + Motor		MOTOR GÜCÜ		MOTOR AKIMI (A)	BASMA BORUSU ÇAPI	POMPA+MOTOR BOYU (mm)	POMPA GÖVDE DIŞ ÇAPI (mm)	AĞIRLIK (Kg)	
		(HP)	(kW)						
ALK 7095 KPS / 3	+ ALK6-17,5	17,5	13	31	BSP G5	1695	172	93	
ALK 7095 KPS / 4	+ ALK6-25	25	18,5	42		1948		110	
ALK 7095 KPS / 5	+ ALK6-30	30	22	49,2		2121		118	
ALK 7095 KPS / 6	+ ALK6-35	35	26	58		2354		133	
ALK 7095 KPS / 7	+ ALK6-40	40	30	66		2592		148	
ALK 7095 KPS / 9	+ ALK6-50	50	37	81		2938		165	
ALK 7095 KPS / 10	+ ALK7-60	60	45	91		2843		180	
ALK 7095 KPS / 12	+ ALK7-80	80	59	119		3285		213	
ALK 7095 KPS / 14	+ ALK8-85	85	63	126		3468		237	
ALK 7095 KPS / 16	+ ALK8-100	100	75	147		3864		272	
ALK 7095 KPS / 20	+ ALK8-125	125	92	182	4576	323			
ALK 8110 KPS / 3	+ ALK6-30	30	22	49,2	BSP G5	1918	191	113	
ALK 8110 KPS / 4	+ ALK6-40	40	30	66		2272		141	
ALK 8110 KPS / 5	+ ALK6-50	50	37	81		2501		156	
ALK 8110 KPS / 6	+ ALK8-60	60	45	90		2390		193	
ALK 8110 KPS / 8	+ ALK8-75	75	55	112		2748		219	
ALK 8110 KPS / 9	+ ALK8-85	85	63	126		2927		231	
ALK 8110 KPS / 10	+ ALK8-100	100	75	147		3176		265	
ALK 8110 KPS / 13	+ ALK8-125	125	92	182		3823		318	
ALK 8125 KPS / 2-AA	+ ALK6-17,5	17,5	13	31		1697		209	104
ALK 8125 KPS / 2-A	+ ALK6-25	25	18,5	42		1822			117
ALK 8125 KPS / 2	+ ALK6-30	30	22	49,2	1867	122			
ALK 8125 KPS / 3-AA	+ ALK6-30	30	22	49,2	2023	128			
ALK 8125 KPS / 3	+ ALK6-40	40	30	66	2238	150			
ALK 8125 KPS / 4	+ ALK6-50	50	37	81	2484	167			
ALK 8125 KPS / 5-A	+ ALK8-60	60	45	90	2390	204			
ALK 8125 KPS / 5	+ ALK8-75	75	55	112	2470	219			
ALK 8125 KPS / 6-A	+ ALK8-75	75	55	112	2626	257			
ALK 8125 KPS / 6	+ ALK8-90	90	66	131	2736	277			
ALK 8125 KPS / 7	+ ALK8-90	90	66	131	2892	286			
ALK 8125 KPS / 8	+ ALK8-100	100	75	147	3118	310			
ALK 8125 KPS / 9	+ ALK8-125	125	92	182	3474	355			
ALK 8125 KPS / 10	+ ALK8-125	125	92	182	3630	364			
ALK 8160 KPS / 1	+ ALK6-17,5	17,5	13	31	1500	207	91		
ALK 8160 KPS / 2	+ ALK6-35	35	26	58	1931		126		
ALK 8160 KPS / 3	+ ALK8-50	50	37	76	1987		176		
ALK 8160 KPS / 4A	+ ALK8-60	60	45	90	2193		190		
ALK 8160 KPS / 4	+ ALK8-75	75	55	112	2273		202		
ALK 8160 KPS / 5	+ ALK8-80	80	59	117	2439		209		
ALK 8160 KPS / 6A	+ ALK8-90	90	66	131	2695		239		
ALK 8160 KPS / 7A	+ ALK8-100	100	75	147	2921		261		
ALK 8160 KPS / 8	+ ALK8-125	125	92	182	3277		304		
ALK 8160 KPS / 9	+ ALK8-150	150	110	220	3583		335		
ALK 8160 KPS / 11	+ ALK10-175	175	129	255	3714	419			
ALK 8160 KPS / 12	+ ALK10-200	200	147	290	3990	448			
ALK 8160 KPS / 14	+ ALK10-225	225	165	325	4372	503			
ALK 8160 KPS / 16	+ ALK10-250	250	185	355	4784	545			

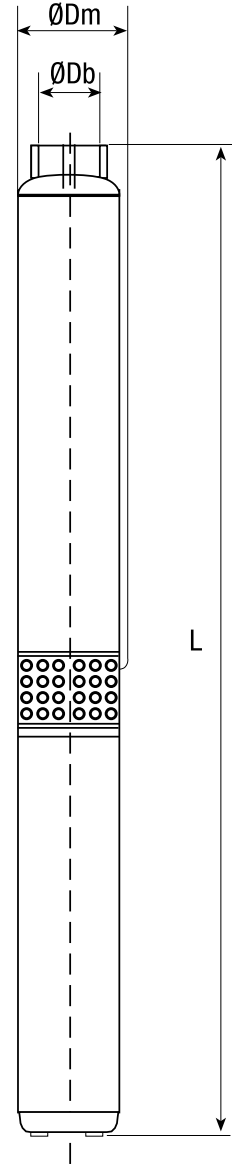



ANA PARÇALAR

1. Ventil Gövdesi: Pompanın üst kısmındadır. Pompa çıkış bağlantısı buraya yapılır. Hassas döküm 304 paslanmaz çelik malzemeden imal edilmiş özel tip bilezik ve genişletilmiş anahtar düzlüğü ile kurulum esnasında ekstra güvenlik.

2. Çekvalf: Kolon borusundaki suyun geri akmasını ve bu akış sonucu motorun ters dönüşünü engeller. Su koçu darbe riskini azaltır.

3. Üst Yatak: Dayanıklı krom malzeme ile kaplıdır. Sert kumlu kuyu koşullarında aşınmayı azaltır.

4. Labirent Bilezikleri: Yüksek pompa verimine ve dayanıklılığına katkıda bulunur. Kendinden merkezleme özelliğine sahiptir.

5. Kablo Muhafazası: Özel olarak inceltilmiş paslanmaz çelik malzemeden yapılmıştır. Dar toleranslı kuyularda montaj esnasında kolaylık sağlar.

6. Pompa İçi "Upthrust" Koruma: Yüksek su ihtiyacının olduğu durumlarda ve ilk kalkışlarda pompanın zarar görmesini engeller. Açık vana ve sık dur/kalk durumlarında arzalara karşı yüksek dayanım sağlar.

7. Emme Filtresi: Aşındırıcı parçaların pompa içerisine girmesini engelleyerek yüksek su ihtiyacının olduğu durumlarda ve ilk kalkışlarda pompanın zarar görmemesini sağlar. 304 paslanmaz çelikten imal edilmiştir.

8. Kaplin Koruyucu Filtre: Aşındırıcı parçaların kaplin ve motor miline zarar vermesini engeller. 304 paslanmaz çelikten imal edilmiştir.

9. Emme Kutusu: Pompa ile motorun birbirine bağlanmasını sağlar. NEMA standardına sahip her tip dalgiç motor ile mükemmel pompa-motor bağlantısını sağlar. Su pompaya emiş ağzından girer. Üzerinde büyük parçaların içeri girmesini engelleyen emme süzgeci bulunur.

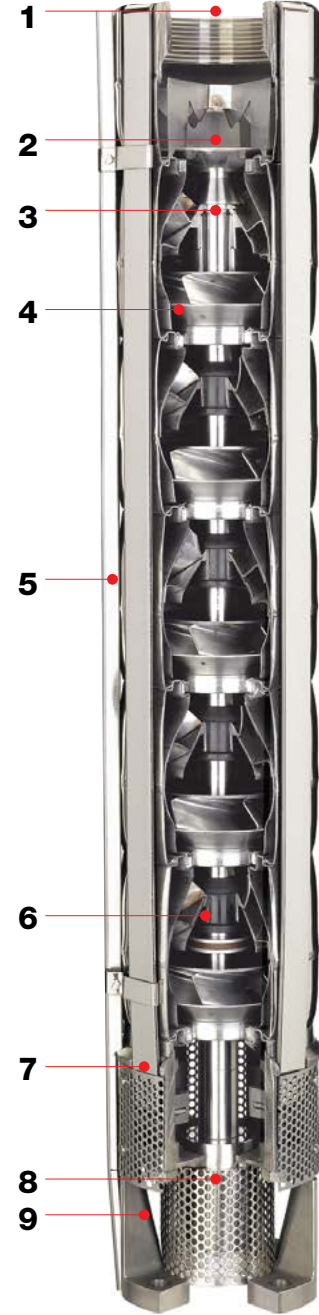



OPSİYONEL ELEKTRİK PANOSU



Standart elektrik panolarına alternatif, Soft Starter Yol Verme özellikli panoların kullanımı ile;

- Pano ve kablo toplam maliyetinde ortalama % 25 'e varan azalma
- 25-180 HP (Yıldız Üçgen Bağlantılı) pompalarda çift kablo yerine tek kablo kullanımı
- Tek kablo kullanımı ile montaj süresinde ortalama % 20 kablo ek süresinde % 50 azalma
- Yumuşak yol vericili sistem kullanımı ile daha düşük pompa arıza oranı ve çok daha yüksek pompa ömrü
- Yumuşak kalkış ve duruşlarla çok daha düşük sukoçu riski
- Daha yüksek teknoloji, daha yüksek müşteri memnuniyeti

SİPARİŞ NOTASYONU

6 046 / 15KPS + AL6 - 30 -T. 60

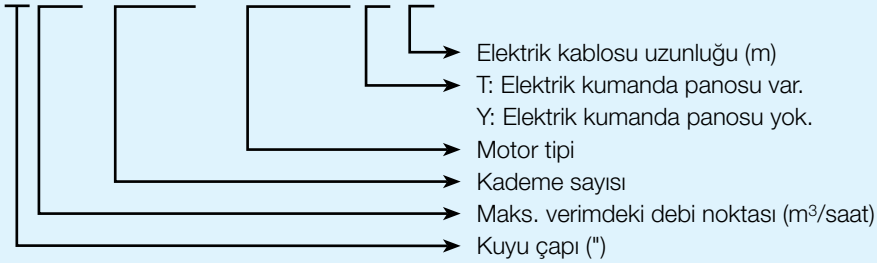

Alrko dalgıç pompalar fabrikadan güvenli biçimde ambalajlanmış olarak sevk edilir. Kontrol panosu, su seviye kontrol elektrodları ve kablo isteğe bağlıdır. İstenirse ikinci bir paket içinde teslim edilirler.

6017 KPS

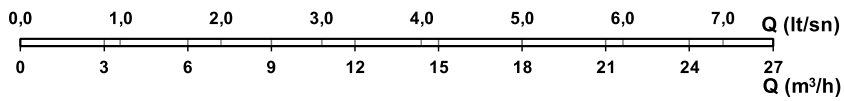
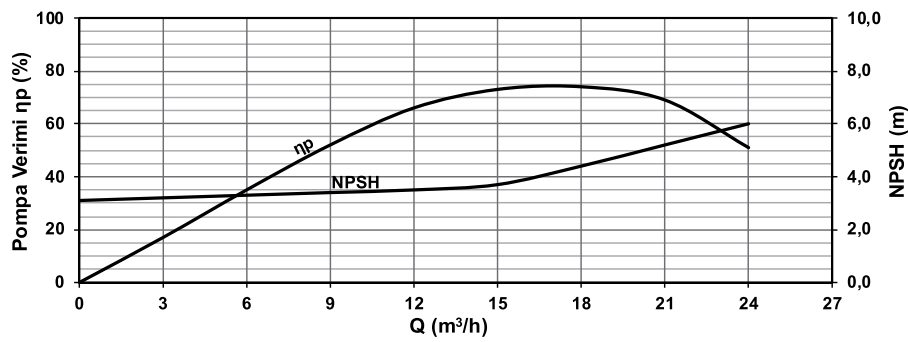
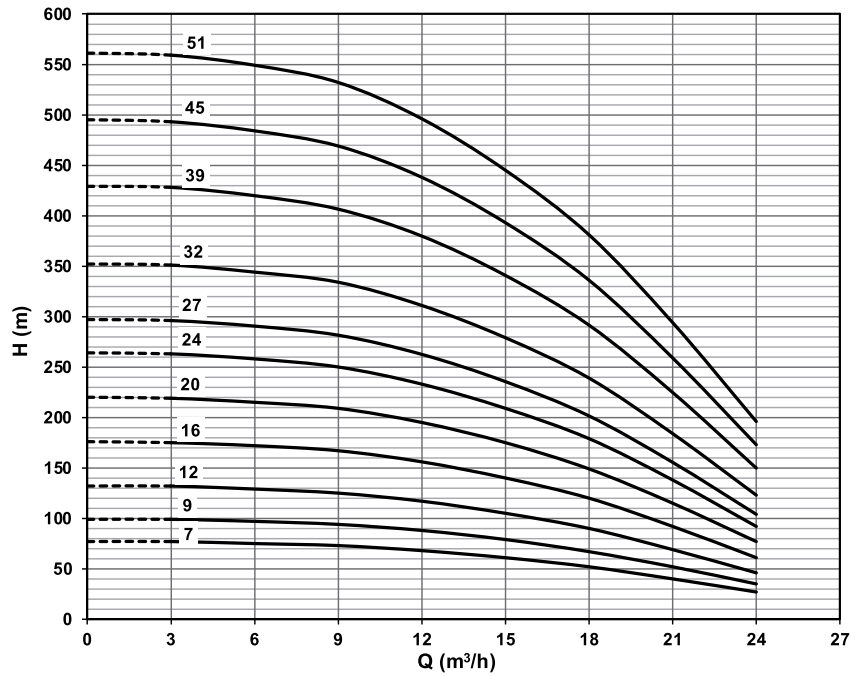



POMPA TİPİ	MOTOR TİPİ HP / kW	DEBİ		0	3	6	9	12	15	18	21	24
		(m ³ / h)	(lt / sn)	0,0	0,8	1,7	2,5	3,3	4,2	5,0	5,8	6,7
		NPSH	(m)	3,1	3,2	3,3	3,4	3,5	3,7	4,4	5,2	6,0
ALK 6017 KPS / 7	ALK 6-5,5HP / 4 kW	H (m)	⇔	77	77	75	73	68	61	52	40	27
ALK 6017 KPS / 9	ALK 6-7,5HP / 5,5 kW			99	99	97	94	88	79	67	52	35
ALK 6017 KPS / 10	ALK 6-10HP / 7,5 kW			110	110	108	104	98	88	74	58	39
ALK 6017 KPS / 12	ALK 6-10HP / 7,5 kW			132	132	129	125	117	105	90	69	46
ALK 6017 KPS / 13	ALK 6-12,5HP / 9,2 kW			143	143	140	136	127	114	98	75	50
ALK 6017 KPS / 15	ALK 6-12,5HP / 9,2 kW			165	164	162	157	146	131	113	87	58
ALK 6017 KPS / 16	ALK 6-12,5HP / 9,2 kW			176	175	172	167	156	140	120	92	61
ALK 6017 KPS / 17	ALK 6-15HP / 11 kW			187	186	183	178	166	149	127	98	65
ALK 6017 KPS / 18	ALK 6-15HP / 11 kW			198	197	194	188	175	157	134	104	69
ALK 6017 KPS / 20	ALK 6-15HP / 11 kW			220	219	215	209	195	175	149	115	77
ALK 6017 KPS / 22	ALK 6-17,5HP / 13 kW			242	241	237	229	214	192	164	127	85
ALK 6017 KPS / 24	ALK 6-17,5HP / 13 kW			264	263	258	250	233	209	179	138	92
ALK 6017 KPS / 25	ALK 6-20HP / 15 kW			275	274	269	261	243	218	187	144	96
ALK 6017 KPS / 27	ALK 6-20HP / 15 kW			297	296	291	282	263	236	202	156	104
ALK 6017 KPS / 28	ALK 6-25HP / 18,5 kW			308	307	301	292	272	244	209	161	108
ALK 6017 KPS / 30	ALK 6-25HP / 18,5 kW			330	329	323	313	292	262	224	173	116
ALK 6017 KPS / 32	ALK 6-25HP / 18,5 kW			352	351	344	334	311	279	239	184	123
ALK 6017 KPS / 33	ALK 6-30HP / 22 kW			363	362	355	344	321	288	246	190	127
ALK 6017 KPS / 35	ALK 6-30HP / 22 kW			385	384	377	365	341	306	261	202	135
ALK 6017 KPS / 37	ALK 6-30HP / 22 kW			407	406	398	386	360	323	277	213	142
ALK 6017 KPS / 39	ALK 6-30HP / 22 kW			429	428	420	406	380	341	291	225	150
ALK 6017 KPS / 41	ALK 6-35HP / 26 kW	451	449	441	428	398	357	307	236	157		
ALK 6017 KPS / 43	ALK 6-35HP / 26 kW	473	471	463	448	418	375	321	248	165		
ALK 6017 KPS / 45	ALK 6-35HP / 26 kW	495	493	484	469	438	393	336	259	173		
ALK 6017 KPS / 47	ALK 6-40HP / 30kW	517	515	506	490	457	410	351	271	181		
ALK 6017 KPS / 49	ALK 6-40HP / 30kW	539	537	528	511	477	428	366	283	188		
ALK 6017 KPS / 51	ALK 6-40HP / 30kW	561	559	549	532	496	445	381	294	196		

Maksimum
verim noktası

6030 KPS

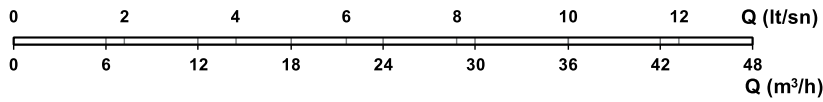
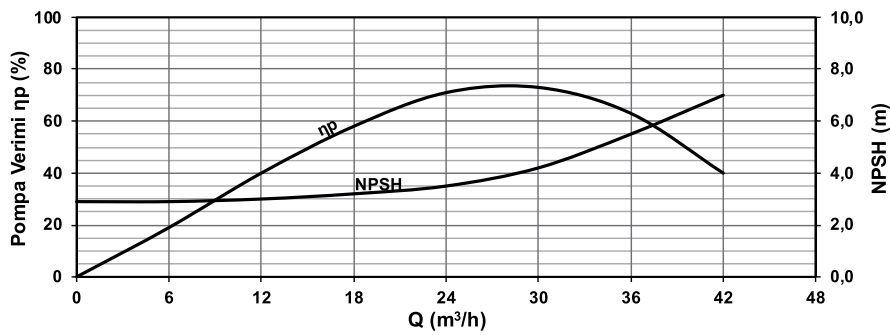
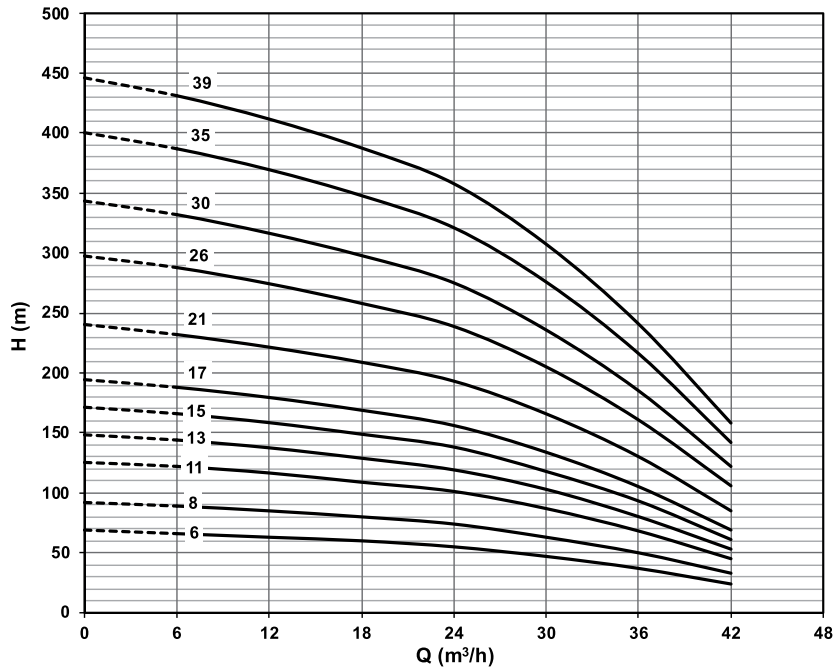



POMPA TİPİ	MOTOR TİPİ HP / kW	DEBİ		0	6	12	18	24	30	36	42
		(m ³ / h)	(lt / sn)	0,0	1,7	3,3	5,0	6,7	8,3	10,0	11,7
		NPSH	(m)	2,9	2,9	3,0	3,2	3,5	4,2	5,5	7,0
ALK 6030 KPS /6	ALK 6-7,5HP / 5,5 kW	H (m)	⇨	69	66	63	60	55	47	37	24
ALK 6030 KPS /7	ALK 6-10HP / 7,5 kW			80	77	74	70	64	55	43	28
ALK 6030 KPS /8	ALK 6-10HP / 7,5 kW			92	89	85	80	74	63	50	33
ALK 6030 KPS /9	ALK 6-12,5HP / 9,2 kW			103	100	95	89	83	71	56	37
ALK 6030 KPS /10	ALK 6-12,5HP / 9,2 kW			114	111	106	99	92	79	62	41
ALK 6030 KPS /11	ALK 6-12,5HP / 9,2 kW			125	122	117	109	101	87	68	45
ALK 6030 KPS /12	ALK 6-15HP / 11 kW			137	133	127	119	110	95	74	49
ALK 6030 KPS /13	ALK 6-15HP / 11 kW			148	144	138	129	119	103	80	53
ALK 6030 KPS /14	ALK 6-17,5HP / 13 kW			160	155	148	139	129	110	87	57
ALK 6030 KPS /15	ALK 6-17,5HP / 13 kW			171	166	159	149	138	118	93	61
ALK 6030 KPS /16	ALK 6-20HP / 15 kW			183	177	169	159	147	126	99	65
ALK 6030 KPS /17	ALK 6-20HP / 15 kW			194	188	180	169	156	134	105	69
ALK 6030 KPS /18	ALK 6-25HP / 18,5 kW			206	199	190	179	165	142	111	73
ALK 6030 KPS /20	ALK 6-25HP / 18,5 kW			229	221	211	199	184	158	124	81
ALK 6030 KPS /21	ALK 6-25HP / 18,5 kW			240	232	222	209	193	166	130	85
ALK 6030 KPS /24	ALK 6-30HP / 22 kW			275	266	254	239	221	189	149	98
ALK 6030 KPS /26	ALK 6-30HP / 22 kW			298	288	274	258	239	205	161	106
ALK 6030 KPS /28	ALK 6-35HP / 26 kW			320	310	296	278	257	221	173	114
ALK 6030 KPS /30	ALK 6-35HP / 26 kW			343	332	317	298	275	236	185	122
ALK 6030 KPS /32	ALK 6-40HP / 30 kW			366	354	338	318	294	252	198	130
ALK 6030 KPS /34	ALK 6-40HP / 30 kW			389	376	359	338	312	268	210	138
ALK 6030 KPS /35	ALK 6-40HP / 30 kW			400	387	370	348	321	276	216	142
ALK 6030 KPS /39	ALK 6-50HP / 37 kW			446	431	412	388	358	307	241	158



**Maksimum
verim noktası**

6046 KPS

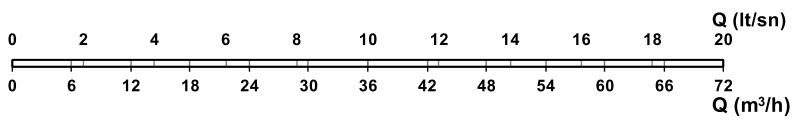
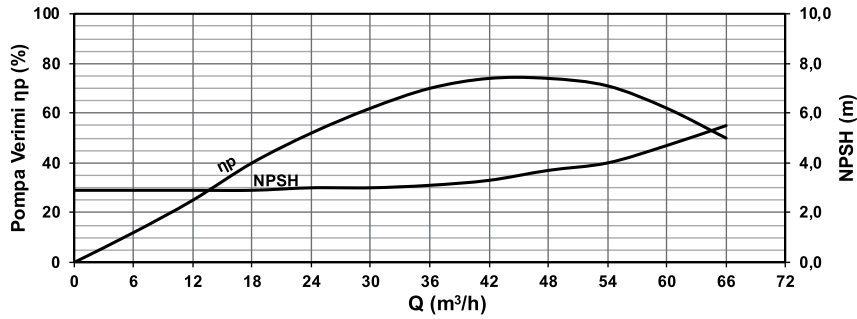
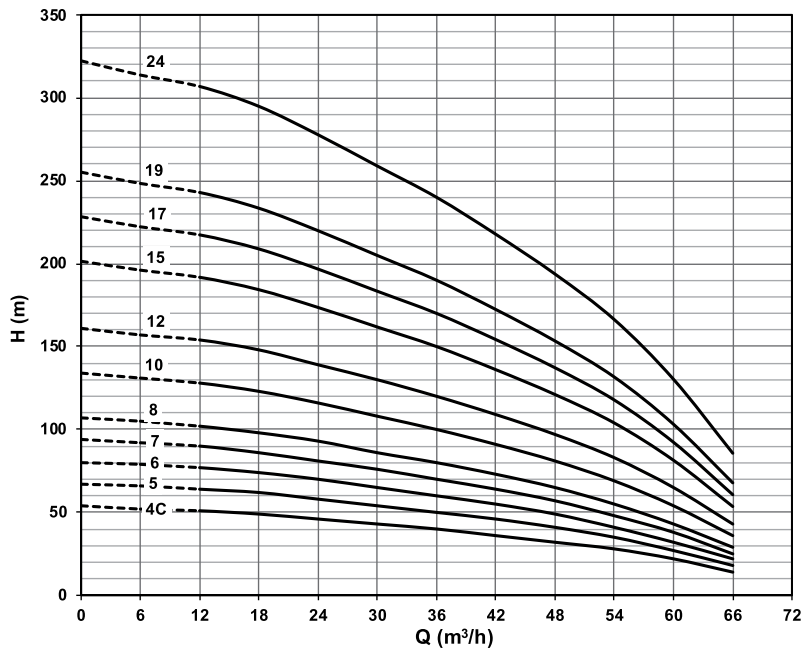



POMPA TİPİ	MOTOR TİPİ HP / kW	DEBİ		H (m)											
		(m ³ / h)	(lt / sn)	0	6	12	18	24	30	36	42	48	54	60	66
		(m)	(m)	0	1,7	3,3	5,0	6,7	8,3	10,0	11,7	13,3	15,0	16,7	18,3
		NPSH	(m)	2,9	2,9	2,9	2,9	3,0	3,0	3,1	3,3	3,7	4,0	4,7	5,5
ALK 6046 KPS / 4C	ALK 6-7,5HP / 5,5 kW	H (m)	⇨	54	52	51	49	46	43	40	36	32	28	22	14
ALK 6046 KPS / 5	ALK 6-10HP / 7,5 kW			67	66	64	62	58	54	50	46	41	35	27	18
ALK 6046 KPS / 6	ALK 6-12,5HP / 9,2 kW			80	79	77	74	70	65	60	55	49	41	32	22
ALK 6046 KPS / 7	ALK 6-15HP / 11 kW			94	92	90	86	81	76	70	64	57	48	38	25
ALK 6046 KPS / 8	ALK 6-17,5HP / 13 kW			107	105	102	98	93	86	80	73	65	55	43	29
ALK 6046 KPS / 9	ALK 6-20HP / 15 kW			121	118	115	111	104	97	90	82	73	62	49	32
ALK 6046 KPS / 10	ALK 6-20HP / 15 kW			134	131	128	123	116	108	100	91	81	69	54	36
ALK 6046 KPS / 11	ALK 6-25HP / 18,5 kW			147	144	141	135	128	119	110	100	89	76	59	40
ALK 6046 KPS / 12	ALK 6-25HP / 18,5 kW			161	157	154	148	139	130	120	109	97	83	65	43
ALK 6046 KPS / 13	ALK 6-30HP / 22 kW			174	170	166	160	151	140	130	118	105	90	70	47
ALK 6046 KPS / 14	ALK 6-30HP / 22 kW			188	183	179	172	162	151	140	127	113	97	76	50
ALK 6046 KPS / 15	ALK 6-30HP / 22 kW			201	196	192	184	174	162	150	136	121	104	81	54
ALK 6046 KPS / 17	ALK 6-35HP / 26 kW			228	222	217	209	197	183	170	154	137	118	92	61
ALK 6046 KPS / 19	ALK 6-40HP / 30kW			255	248	243	233	220	205	190	172	153	132	103	68
ALK 6046 KPS / 21	ALK 6-50HP / 37 kW			282	275	269	258	243	227	210	191	170	146	114	75
ALK 6046 KPS / 23	ALK 6-50HP / 37 kW			309	301	294	283	266	248	230	209	186	159	125	82
ALK 6046 KPS / 24	ALK 6-50HP / 37 kW			322	314	307	295	278	259	240	218	194	166	130	86

Maksimum
verim noktası

6060 KPS

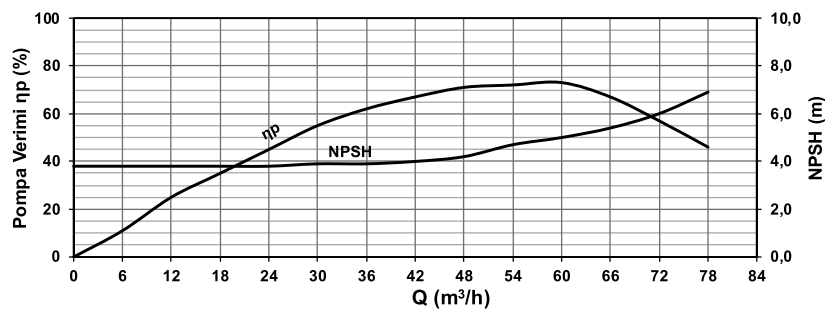
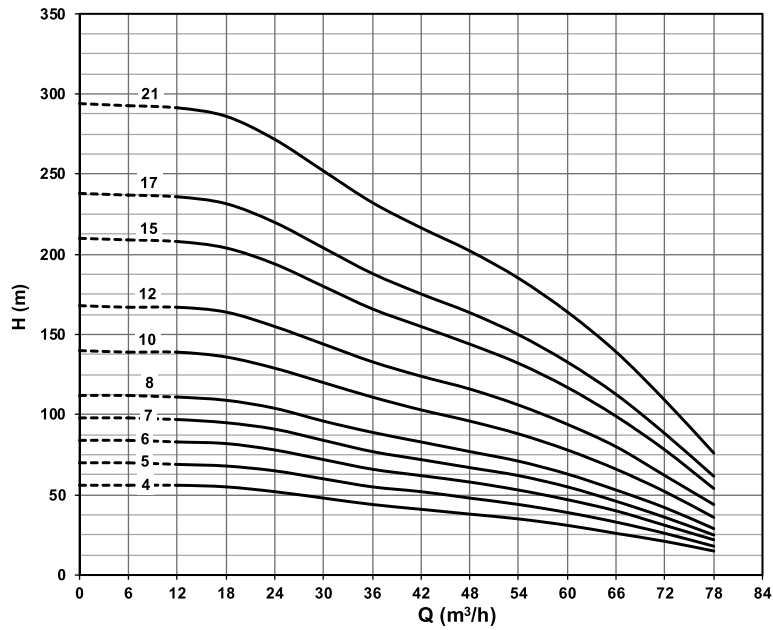



POMPA TİPİ	MOTOR TİPİ HP / kW	DEBİ																
		(m³ / h)	0	6	12	18	24	30	36	42	48	54	60	66	72	78		
		(lt / sn)	0	1,7	3,3	5,0	6,7	8,3	10,0	11,7	13,3	15,0	16,7	18,3	20,0	21,7		
		NPSH	(m)	3,8	3,8	3,8	3,8	3,8	3,9	3,9	4,0	4,2	4,7	5,0	5,4	6,0	6,9	
ALK 6060 KPS / 4	ALK 6-10HP / 7,5 kW	H (m)	⇔	56	56	56	55	52	48	44	41	38	35	31	26	21	15	
ALK 6060 KPS / 5	ALK 6-12,5HP / 9,2 kW			70	70	69	68	65	60	55	52	48	44	39	33	26	18	
ALK 6060 KPS / 6	ALK 6-15HP / 11 kW			84	84	83	82	78	72	66	62	58	53	47	40	31	22	
ALK 6060 KPS / 7	ALK 6-17,5HP / 13 kW			98	98	97	95	91	84	77	72	67	62	55	46	36	25	
ALK 6060 KPS / 8	ALK 6-20HP / 15 kW			112	112	111	109	104	96	89	83	77	71	63	53	42	29	
ALK 6060 KPS / 10	ALK 6-25HP / 18,5 kW			140	139	139	136	129	120	111	103	96	88	78	66	52	36	
ALK 6060 KPS / 12	ALK 6-30HP / 22 kW			168	167	167	164	155	144	133	124	116	106	94	80	62	44	
ALK 6060 KPS / 14	ALK 6-35HP / 26 kW			196	195	194	191	181	168	155	144	135	123	109	93	73	51	
ALK 6060 KPS / 15	ALK 6-35HP / 26 kW			210	209	208	204	194	180	166	155	144	132	117	99	78	54	
ALK 6060 KPS / 16	ALK 6-40HP / 30kW			224	223	222	218	207	192	177	165	154	141	125	106	83	58	
ALK 6060 KPS / 17	ALK 6-40HP / 30kW			238	237	236	232	220	204	188	175	164	150	133	113	88	62	
ALK 6060 KPS / 19	ALK 6-50HP / 37 kW			266	265	264	259	246	228	210	196	183	167	148	126	99	69	
ALK 6060 KPS / 20	ALK 6-50HP / 37 kW			280	279	278	273	259	240	221	206	193	176	156	133	104	73	
ALK 6060 KPS / 21	ALK 6-50HP / 37 kW			294	293	291	286	272	252	232	217	202	185	164	139	109	76	



**Maksimum
verim noktası**

7077 KPS

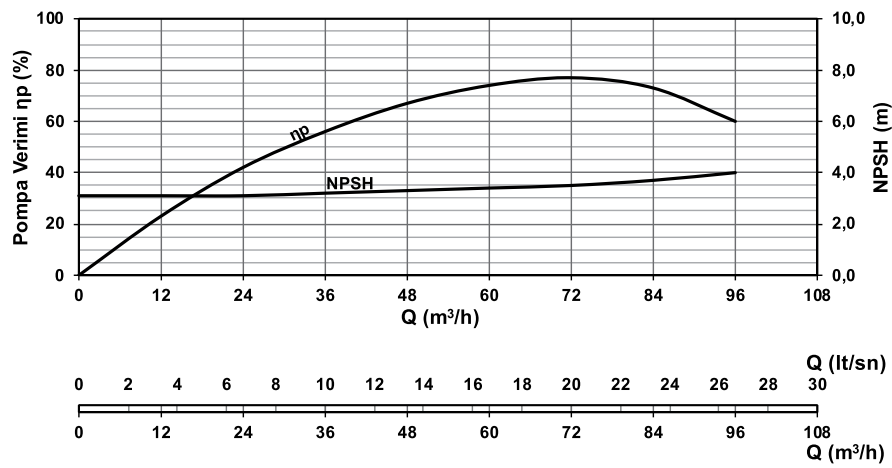
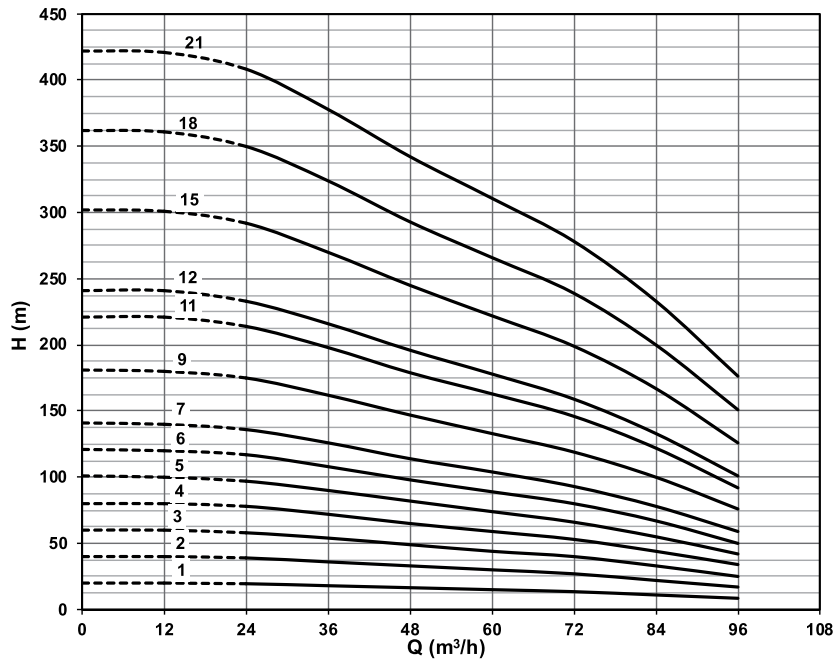



POMPA TİPİ	MOTOR TİPİ HP / kW	DEBİ											
		(m ³ / h)	0	12	24	36	48	60	72	84	96		
		(lt / sn)	0	3,3	6,7	10,0	13,3	16,7	20,0	23,3	26,7		
NPSH	(m)	3,1	3,1	3,1	3,2	3,3	3,4	3,5	3,7	4,0			
ALK 7077 KPS / 1	ALK 6-7,5HP / 5,5 kW	H (m)	⇨	20	20	20	18	17	15	14	11	9	
ALK 7077 KPS / 2	ALK 6-10HP / 7,5 kW			40	40	39	36	33	30	27	22	17	
ALK 7077 KPS / 3	ALK 6-15HP / 11 kW			60	60	58	54	49	44	40	33	25	
ALK 7077 KPS / 4	ALK 6-20HP / 15 kW			80	80	78	72	65	59	53	44	34	
ALK 7077 KPS / 5	ALK 6-25HP / 18,5 kW			101	100	97	90	82	74	66	55	42	
ALK 7077 KPS / 6	ALK 6-30HP / 22 kW			121	120	117	108	98	89	80	67	50	
ALK 7077 KPS / 7	ALK 6-35HP / 26 kW			141	140	136	126	114	104	93	78	59	
ALK 7077 KPS / 8	ALK 6-40HP / 30kW			161	160	156	144	130	118	106	89	67	
ALK 7077 KPS / 9	ALK 6-40HP / 30kW			181	180	175	162	147	133	119	100	76	
ALK 7077 KPS / 10	ALK 6-50HP / 37 kW			201	201	195	180	163	148	133	111	84	
ALK 7077 KPS / 11	ALK 6-50HP / 37 kW			221	221	214	198	179	163	146	122	92	
ALK 7077 KPS / 12	ALK 7-60HP / 45 kW			241	241	233	216	196	178	159	133	101	
ALK 7077 KPS / 13	ALK 7-80HP / 59 kW			261	261	253	234	212	192	172	144	109	
ALK 7077 KPS / 15	ALK 7-80HP / 59 kW			302	301	292	270	245	222	199	167	126	
ALK 7077 KPS / 16	ALK 8-85HP / 63 kW			322	321	311	288	261	237	212	178	134	
ALK 7077 KPS / 17	ALK 8-85HP / 63 kW			342	341	331	306	277	252	225	189	143	
ALK 7077 KPS / 18	ALK 8-85HP / 63 kW			362	361	350	324	293	266	239	200	151	
ALK 7077 KPS / 20	ALK 8-100HP / 75 kW			402	401	389	360	326	296	265	222	168	
ALK 7077 KPS / 21	ALK 8-100HP / 75 kW			422	421	408	378	342	311	278	233	176	



**Maksimum
verim noktası**

7095 KPS

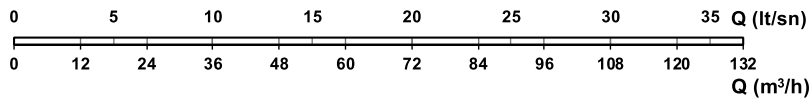
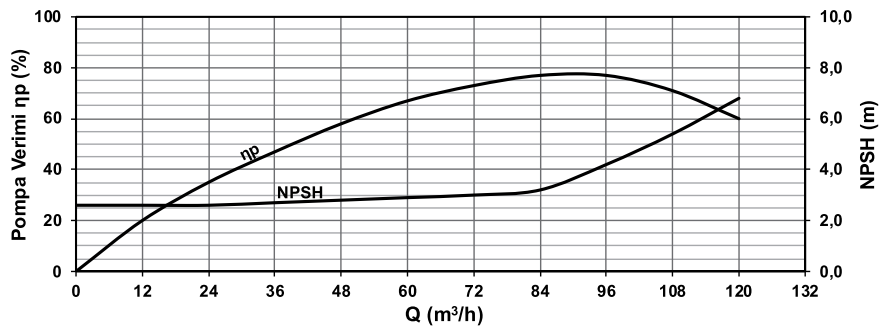
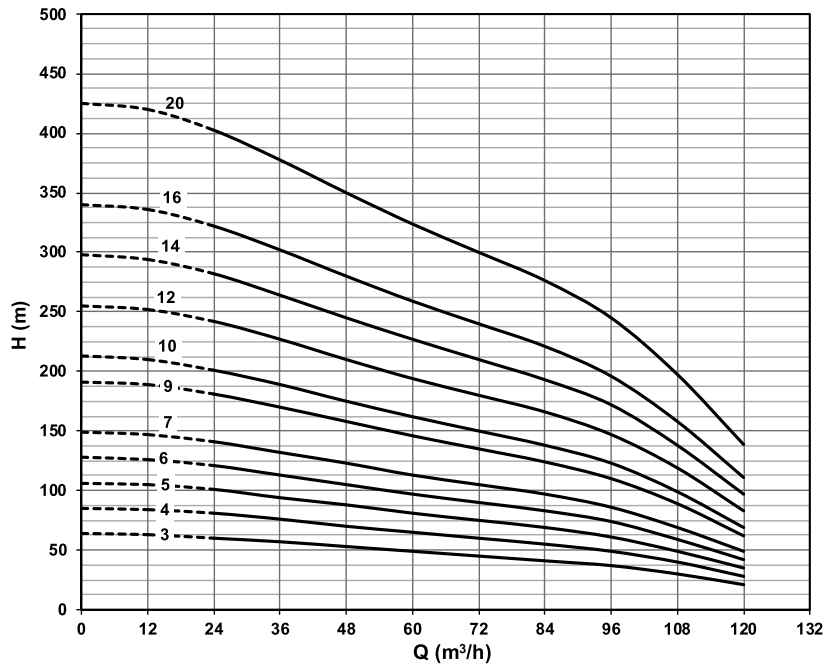



POMPA TİPİ	MOTOR TİPİ HP / kW	DEBİ												
		(m ³ / h)	0	12	24	36	48	60	72	84	96	108	120	
		(lt / sn)	0,0	3,3	6,7	10,0	13,3	16,7	20,0	23,3	26,7	30,0	33,3	
		NPSH	(m)	2,6	2,6	2,6	2,7	2,8	2,9	3,0	3,2	4,2	5,4	6,8
ALK 7095 KPS / 3	ALK 6-17,5HP / 13 kW	H (m)	⇨	64	63	60	57	53	49	45	41	37	30	21
ALK 7095 KPS / 4	ALK 6-25HP / 18,5 kW			85	84	81	76	70	65	60	55	49	40	28
ALK 7095 KPS / 5	ALK 6-30HP / 22 kW			106	105	101	94	88	81	75	69	61	49	35
ALK 7095 KPS / 6	ALK 6-35HP / 26 kW			128	126	121	113	105	97	90	83	74	59	42
ALK 7095 KPS / 7	ALK 6-40HP / 30kW			149	147	141	132	123	113	105	97	86	69	49
ALK 7095 KPS / 9	ALK 6-50HP / 37 kW			191	189	181	170	158	146	135	124	110	89	62
ALK 7095 KPS / 10	ALK 7-60HP / 45 kW			213	210	201	189	175	162	150	138	123	99	69
ALK 7095 KPS / 11	ALK 7-80HP / 59 kW			234	231	221	208	193	178	165	152	135	109	76
ALK 7095 KPS / 12	ALK 7-80HP / 59 kW			255	252	242	227	210	194	180	166	147	119	83
ALK 7095 KPS / 13	ALK 8-85HP / 63 kW			276	273	262	245	228	210	195	180	159	128	90
ALK 7095 KPS / 14	ALK 8-85HP / 63 kW			298	294	282	264	245	227	210	193	172	138	97
ALK 7095 KPS / 15	ALK 8-100HP / 75 kW			319	315	302	283	263	243	225	207	184	148	104
ALK 7095 KPS / 16	ALK 8-100HP / 75 kW			340	336	322	302	280	259	240	221	196	158	111
ALK 7095 KPS / 20	ALK 8-125HP / 92 kW			425	420	403	378	350	324	300	276	245	198	139



Maksimum
verim noktası

8110 KPS

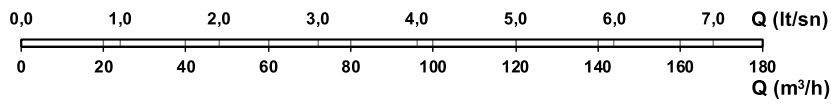
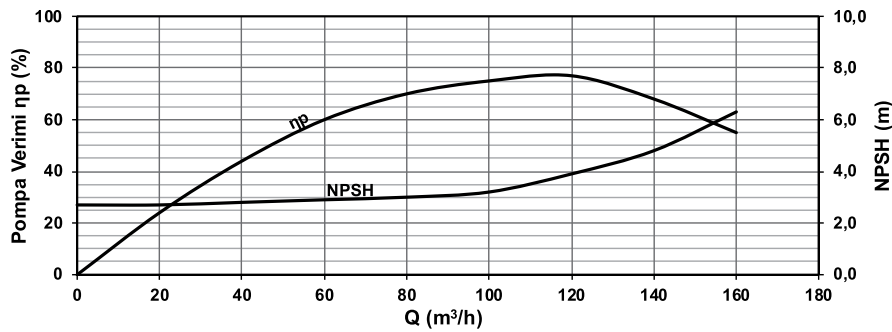
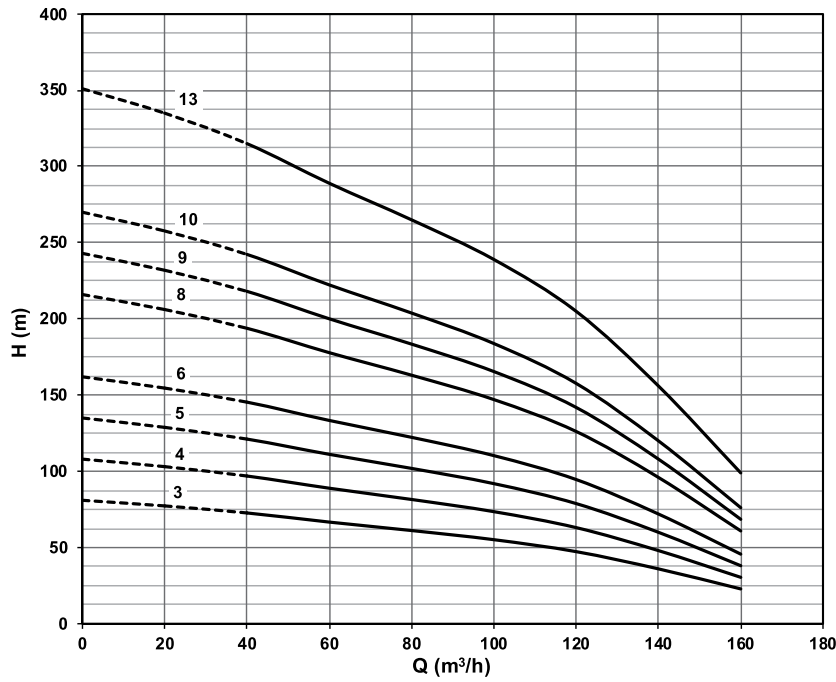



POMPA TİPİ	MOTOR TİPİ HP / kW	DEBİ		0	20	40	60	80	100	120	140	160
		(m ³ / h)	(lt / sn)	0	5,6	11,1	16,7	22,2	27,8	33,3	38,9	44,4
		NPSH	(m)	2,7	2,7	2,8	2,9	3,0	3,2	3,9	4,8	6,3
ALK 8110 KPS / 3	ALK 6-30HP / 22 kW	H (m)	⇔	81	77	73	67	61	55	47	36	23
ALK 8110 KPS / 4	ALK 6-40HP / 30kW			108	103	97	89	82	74	63	48	30
ALK 8110 KPS / 5	ALK 6-50HP / 37 kW			135	129	121	111	102	92	79	60	38
ALK 8110 KPS / 6	ALK 8-60HP / 45 kW			162	155	145	133	122	110	95	72	46
ALK 8110 KPS / 7	ALK 8-75HP / 55 kW			189	180	170	156	143	129	110	84	53
ALK 8110 KPS / 8	ALK 8-75HP / 55 kW			216	206	194	178	163	147	126	96	61
ALK 8110 KPS / 9	ALK 8-85HP / 63 kW			243	232	218	200	183	165	142	108	69
ALK 8110 KPS / 10	ALK 8-100HP / 75 kW			270	258	242	222	204	184	158	120	76
ALK 8110 KPS / 13	ALK 8-125HP / 92 kW			351	335	315	289	265	239	205	156	99



**Maksimum
verim noktası**

8125 KPS

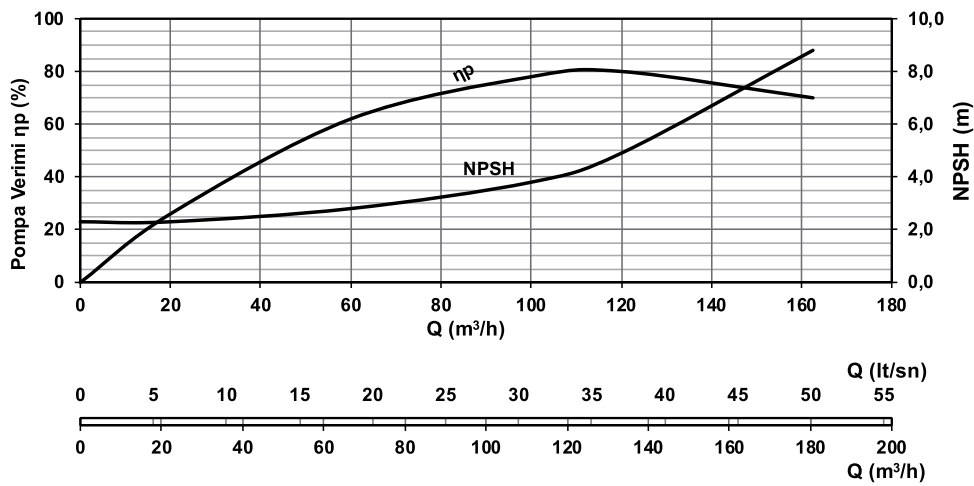
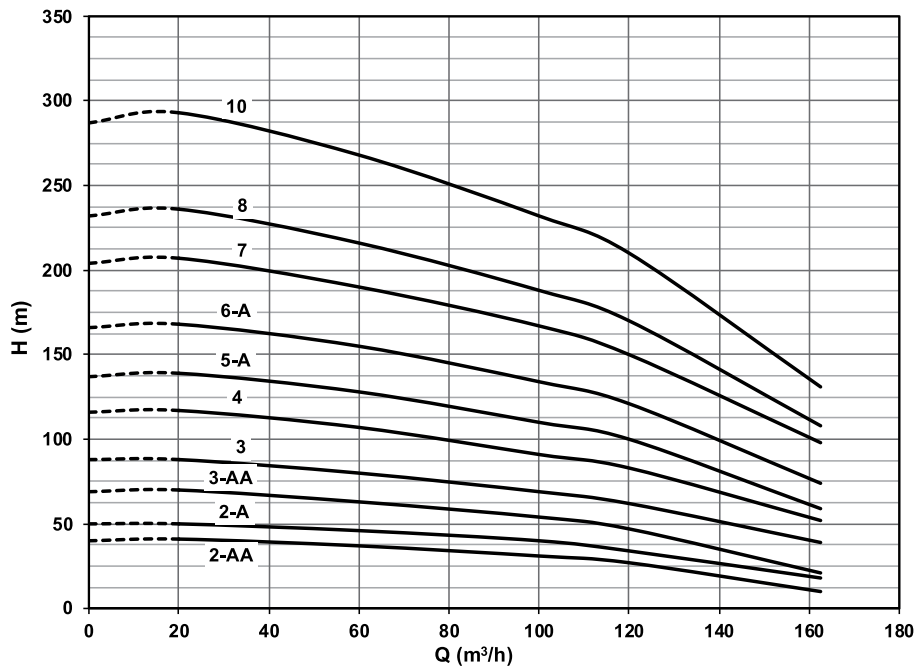



POMPA TİPİ	MOTOR TİPİ HP / kW	DEBİ		0	20	60	100	120	163
		(m ³ / h)	(lt / sn)	0	5,6	16,7	27,8	33,3	45,1
		NPSH	(m)	2,3	2,3	2,8	3,8	4,9	8,8
ALK 8125 KPS / 2-AA	ALK 6-17,5HP /13 kW	H (m)	⇔	40	41	37	31	27	10
ALK 8125 KPS / 2-A	ALK 6-25HP /18,5 kW			50	50	46	40	34	18
ALK 8125 KPS / 2	ALK 6-30HP /22 kW			59	60	54	46	41	26
ALK 8125 KPS / 3-AA	ALK 6-30HP /22 kW			69	70	63	54	47	21
ALK 8125 KPS / 3	ALK 6-40HP /30kW			88	88	80	69	62	39
ALK 8125 KPS / 4	ALK 6-50HP /37 kW			116	117	107	91	83	52
ALK 8125 KPS / 5-A	ALK 8-60HP /45 kW			137	139	128	110	100	59
ALK 8125 KPS / 5	ALK 8-75HP /55 kW			147	149	136	118	108	70
ALK 8125 KPS / 6-A	ALK 8-75HP /55 kW			166	168	155	134	121	74
ALK 8125 KPS / 6	ALK 8-90HP /66 kW			176	178	164	143	130	85
ALK 8125 KPS / 7	ALK 8-90HP /66 kW			204	207	190	167	150	98
ALK 8125 KPS / 8	ALK 8-100HP /75 kW			232	236	216	188	170	108
ALK 8125 KPS / 9	ALK 8-125HP /92 kW			260	265	242	210	190	120
ALK 8125 KPS / 10	ALK 8-125HP /92 kW			287	293	268	232	210	131



8160 KPS

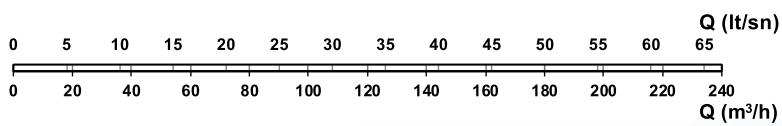
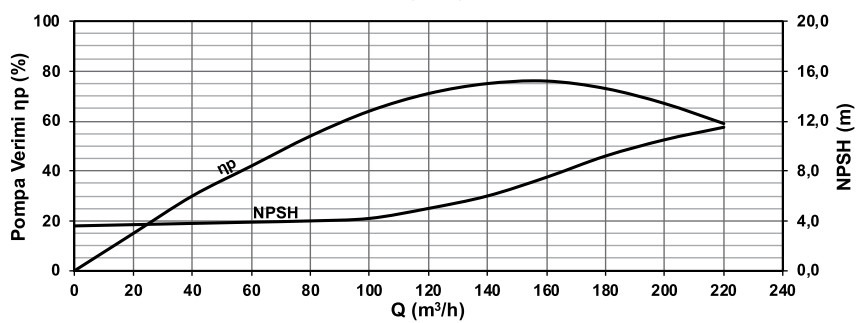
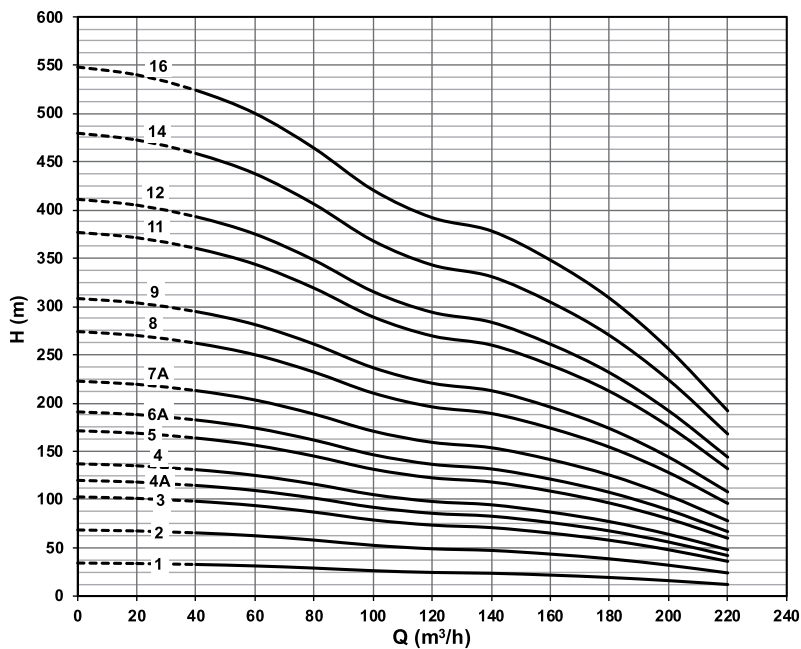

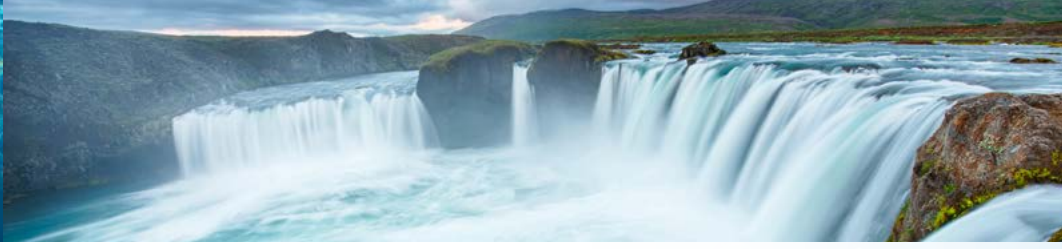

POMPA TİPİ	MOTOR TİPİ HP / kW	DEBİ														
		(m ³ / h)	0	20	40	60	80	100	120	140	160	180	200	220		
		(lt / sn)	0	5,6	11,1	16,7	22,2	27,8	33,3	38,9	44,4	50,0	55,6	61,1		
		NPSH	(m)	3,6	3,7	3,8	3,9	4,0	4,2	5,0	6,0	7,5	9,2	10,5	11,5	
ALK 8160 KPS / 1	ALK 6-17,5HP / 13 kW	H (m)	⇨	34	34	33	31	29	26	25	24	22	19	16	12	
ALK 8160 KPS / 2	ALK 6-35HP / 26 kW			69	68	66	63	58	53	49	47	44	39	32	24	
ALK 8160 KPS / 3	ALK 8-50HP / 37 kW			103	101	98	94	87	79	74	71	65	58	48	36	
ALK 8160 KPS / 4A	ALK 8-60HP / 45 kW			120	118	115	109	102	92	86	83	76	68	56	42	
ALK 8160 KPS / 4	ALK 8-75HP / 55 kW			137	135	131	125	116	105	98	95	87	77	64	48	
ALK 8160 KPS / 5	ALK 8-80HP / 59 kW			171	169	164	156	145	131	123	118	109	96	80	60	
ALK 8160 KPS / 6A	ALK 8-90HP / 66 kW			191	188	182	174	162	146	137	132	121	107	89	67	
ALK 8160 KPS / 6	ALK 8-100HP / 75 kW			206	203	197	188	174	158	147	142	131	116	96	72	
ALK 8160 KPS / 7A	ALK 8-100HP / 75 kW			223	219	213	203	189	171	159	154	141	125	104	78	
ALK 8160 KPS / 7	ALK 8-125HP / 92 kW			240	236	229	219	203	184	172	166	152	135	112	84	
ALK 8160 KPS / 8	ALK 8-125HP / 92 kW			274	270	262	250	232	210	196	189	174	154	128	96	
ALK 8160 KPS / 9	ALK 8-150HP / 110 kW			308	304	295	281	261	237	221	213	196	174	144	108	
ALK 8160 KPS / 10	ALK 10-175HP / 129 kW			343	338	328	313	290	263	245	236	218	193	160	120	
ALK 8160 KPS / 11	ALK 10-175HP / 129 kW			377	371	360	344	319	289	270	260	239	212	176	132	
ALK 8160 KPS / 12	ALK 10-200HP / 147 kW			411	405	393	375	348	315	294	284	261	231	192	144	
ALK 8160 KPS / 13	ALK 10-225HP / 165 kW			445	439	426	406	377	342	319	307	283	251	208	156	
ALK 8160 KPS / 14	ALK 10-225HP / 165 kW	480	473	459	438	406	368	343	331	305	270	224	168			
ALK 8160 KPS / 15	ALK 10-250HP / 185 kW	514	506	491	469	435	394	368	355	326	289	240	180			
ALK 8160 KPS / 16	ALK 10-250HP / 185 kW	548	540	524	500	464	421	392	378	348	309	256	192			



Maksimum
verim noktası

GÜVENLİ VE VERİMLİ KULLANIM İÇİN

- Kuyu suyu sıcaklığı ve kuyu suyundaki kum miktarı laboratuvarında kontrol ettirilmelidir. Kuyu suyundaki maksimum kum miktarı 30 gr/m³, maksimum kuyu sıcaklığı 30°C olmalıdır.
- Borular ve boru kelepçeleri pompa grubunu, düşey borudaki suyu ve kendi ağırlığını taşıyacak mukavemette olmalıdır.
- Kuyu çapının pompa çapından en az 2" (inç) büyük olması tavsiye edilir.

- Pompa emme süzgeci ile kuyu filtre süzgeci arasındaki mesafe maksimum uzaklıkta olmalıdır.
- Motorun alt ucu ile kuyu tabanı arası en az 50 cm olmalıdır. Pompanın kuyuya indirilme boyu buna göre belirlenir.
- Pompanın montaj derinliği hava emmemesi için çalışabileceği minimum derinlik olan Net Pozitif Emme Yüksekliği (NPSH) değerlerine uygun olmalıdır.

UYGULAMA ŞEKİLLERİ

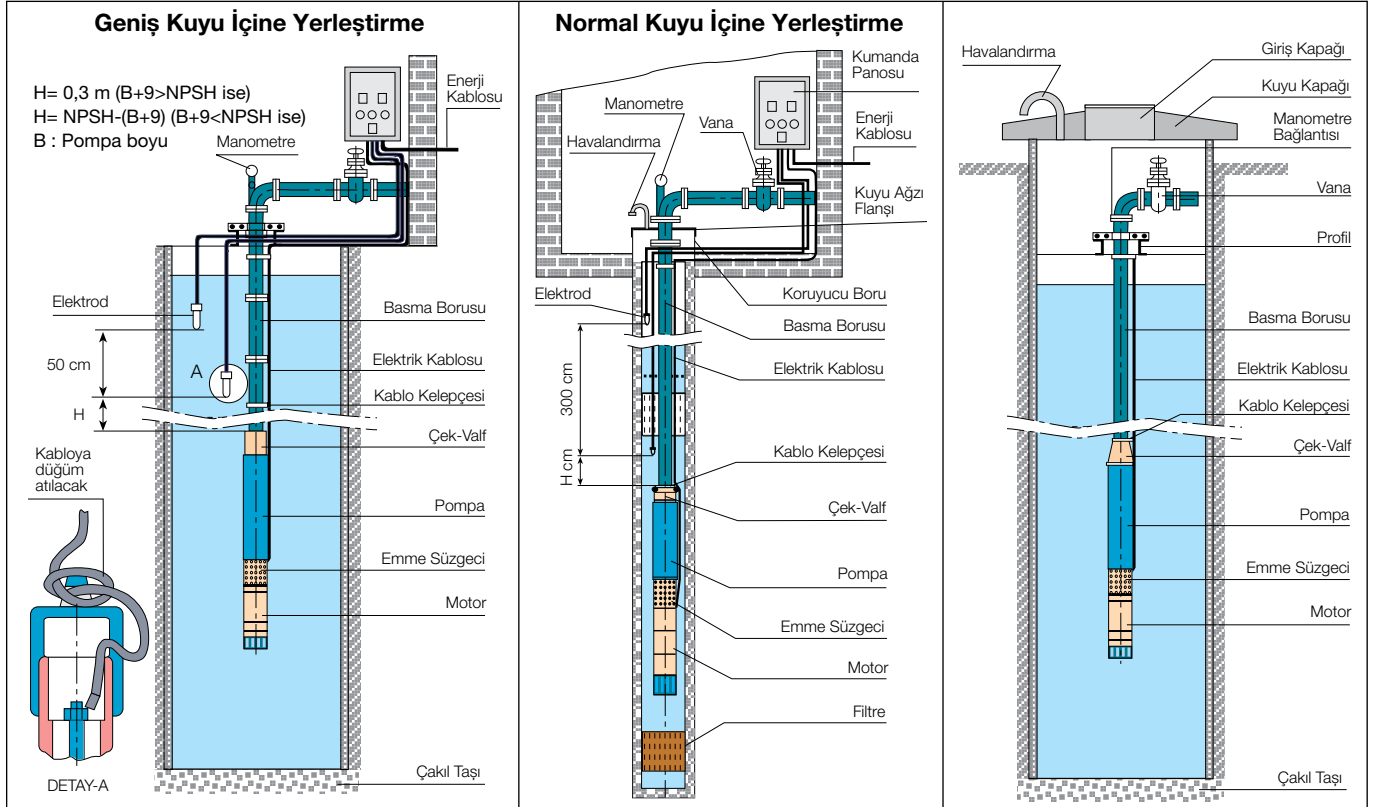

Not: Teknolojik gelişmeler nedeniyle değişiklik hakkı saklıdır.

ALARKO

Carrier

ALARKO CARRIER
SANAYİ VE TİCARET A.Ş.

İSTANBUL: GOSB-Gebe Organize Sanayi Bölgesi Ş. Bilgisu Cad. Gebe 41480 KOCAELİ
Tel: (0262) 648 60 00 Faks: (0 262) 648 61 01

ANKARA: Sedat Simavi Sok. No: 48, Çankaya 06550 ANKARA
Tel: (0312) 409 52 00 Faks: (0312) 440 79 30

İZMİR: Şehit Fethibey Cad. No: 55 Kat 13, Pasaport 35210 İZMİR
Tel: (0232) 483 25 60 Faks: (0232) 441 55 13

ADANA: Ziyapaşa Bulvarı, No: 19/5-6, 01130 ADANA
Tel: (0322) 457 62 23 Faks: (0322) 453 05 84

ANTALYA: Mehmetçik Mahallesi, Aspendos Bulvarı, No:79/5 ANTALYA
Tel: (0242) 322 00 29 Faks: (0242) 322 87 66

MÜŞTERİ
DANIŞMA
HATTI

444 0 128

www.alarko-carrier.com.tr

info@alarko-carrier.com.tr